

STATIC TRANSFER SWITCH 2

USER MANUAL

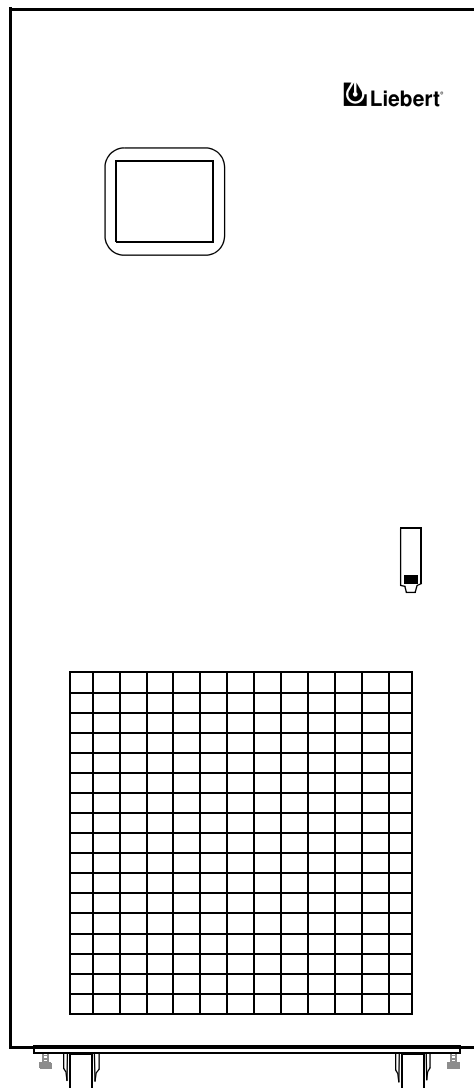

100-1000 Amp
50-60 Hz

TABLE OF CONTENTS

IMPORTANT SAFETY INSTRUCTIONS	1
OVERVIEW OF MANUAL	2
1.0 SAFETY PRECAUTIONS	3
2.0 UNPACKING AND INSPECTIONS	4
2.1 External Inspections	4
2.2 Unloading and Handling	4
2.2.1 Handling Considerations	5
2.2.2 Unit Preparation	5
2.3 Internal Inspections	5
3.0 LOCATION CONSIDERATIONS	6
3.1 Recommended Minimum Service Clearances	6
3.2 Heat Output	6
3.3 Operating Environment	6
3.4 Altitude	7
4.0 LOCATING THE STS2	8
4.1 Leveling and Anchoring the Unit to the Floor	8
4.2 Leveling of the Static Switch Without Anchoring	8
4.3 Leveling and Anchoring the Static Switch Using Floor Stand	8
5.0 POWER AND CONTROL WIRING	9
5.1 Input And Output Power Connections	9
5.2 Input Junction Box Installation (Optional)	10
5.3 System Grounding	11
5.4 Control Wiring Connections	11
5.5 Remote Source Selection Wiring	12
5.6 Power Supply	12
6.0 OPTIONS	13
6.1 Programmable Relay Board	13
6.2 Optimized Transfer	13
6.3 Distribution Cabinet With I-Line Panelboard—100-600A Units Only	14
6.4 Input Contact Isolator Board	14
6.5 Comms Board	14
6.6 Internal Modem	14
6.7 Network Interface Card (NIC)	15
6.8 LED Display	15
6.9 Remote Source Selection	15
6.10 Key Lockout Switch	15
6.11 Redundant Output Breaker	15

6.12	Input Junction Boxes and Cables	16
6.13	Seismic Floor Anchors	16
6.14	Seismic Floor Stand	16
7.0	INSTALLATION DRAWINGS	17
8.0	INTRODUCTION TO STS2 OPERATIONS	57
8.1	System Description	57
8.1.1	Redundancy	57
8.1.2	Reliability and Agency Requirements	58
8.1.3	Factory Backup and Service Assistance	58
8.2	Modes of Operation	58
8.2.1	Normal (Preferred Source)	58
8.2.2	Transfer	58
8.2.3	Transfer Inhibit	58
8.2.4	Bypass	59
8.3	Operator Controls	59
9.0	THEORY OF OPERATION	60
9.1	General Description	60
9.1.1	STS2 Static Transfer Switch	60
9.1.2	Source Transfer	60
9.1.3	Automatic Transfer/Retransfer	60
9.1.4	Emergency Transfer	61
9.1.5	Load Current Transfer Inhibit	61
9.1.6	SCR Failure	61
9.1.7	On/Off Sequence	61
9.2	Detailed Component Description	61
9.2.1	Controls	61
9.2.2	Circuit Breakers	62
9.2.3	SCRs	62
9.2.4	Logic Modules	63
9.2.5	Audible Alarm	63
9.2.6	RS-232 Port	63
10.0	OPERATING INSTRUCTIONS FOR THE TOUCH SCREEN INTERFACE	64
10.1	Normal System Turn-On	65
10.2	Manual Transfer / Preferred Source Selection	66
10.3	Enabling Remote Source Selection	67
10.4	Maintenance Bypass	67
10.4.1	Bypass Procedures for Source 1	69
10.4.2	Bypass Procedures for Source 2	70
10.5	Normal System Shutdown	70
10.5.1	Shutdown in Static Transfer Switch Mode	70
10.5.2	Shutdown in Maintenance Bypass Mode	70
11.0	ALARM AND FAULTS	71
11.1	Event Mask	71

11.2	Event and History Logs	72
11.2.1	Event Log	72
11.2.2	History Log	72
11.3	Alarm Notes	73
11.4	List of Messages	74
12.0	COMMUNICATION INTERFACES	76
12.1	Using the RS-232 Port	76
12.1.1	Connecting and Using a Terminal	77
12.1.2	Configuring the STS2 via the Terminal	78
12.1.3	Setting Bitpacked Options with the Terminal	81
12.1.4	Setting Event Masks with the Terminal	83
13.0	STS2 TOUCH SCREEN DISPLAY	85
13.1	Display Overview	85
13.2	Menu Overview	86
13.2.1	Security	87
13.3	Mimic Display	88
13.4	Event Controls	88
13.5	Event Display	88
13.6	Menu bar	88
13.6.1	Configuration Menu	88
13.6.2	Logs	101
13.6.3	Source Transfers	102
13.6.4	Startup Procedure	102
13.6.5	Bypass Procedure	102
13.6.6	Help	102
13.6.7	Logo	102
13.7	Cleaning the LCD Touch Screen	102
14.0	OPERATING THE LED DISPLAY STS2	103
14.1	LEDs and Buttons and Key Lockout Switch	103
14.1.1	Front Panel Controls	103
14.1.2	LED and push button description	104
14.1.3	Event Controls	105
14.1.4	Key Lockout Switch	105
14.2	Operations	105
14.2.1	Normal System Turn-On	105
14.2.2	Manual Transfer / Preferred Source Selection	106
14.2.3	Maintenance Bypass	107
14.2.4	Normal System Shutdown	109

15.0	SPECIFICATIONS	110
15.1	System Configuration	110
15.1.1	Frequency	110
15.1.2	Input/Output Voltage	110
15.1.3	System Current Ratings	110
15.1.4	Grounding	111
15.1.5	Electrical Requirements	111
15.1.6	Input Surge Suppression	111
15.1.7	Response Time	111
15.1.8	Environmental Requirements	111
15.2	System Components	112
15.2.1	Frame and Enclosure	112
15.2.2	Castors, Leveling and Seismic Anchoring	112
15.2.3	Cooling	112
15.2.4	Access	113
15.2.5	Circuit Breakers	113
15.2.6	Cable Entrance	113
15.2.7	Doors	113
15.2.8	Color Graphical Display or LED Display	113
15.2.9	RS-232 Port	114
15.2.10	Terminal Port Connections	114
15.2.11	RS-232 Interface Parameters	115
15.2.12	Maintenance Bypass	115
15.2.13	Fuseless Design	115
15.2.14	Options	115
16.0	EVENT MESSAGE HELP TEXT	116
17.0	MAINTENANCE	137
17.1	Proper Tightening of Nuts and Bolts	137
17.2	Testing the STS2	137
17.3	Changing the Air Filter	137
	SUPPORT INFORMATION	138
	PROGRAMMABLE RELAY BOARD SETTINGS RECORD	139
	INPUT CONTACT ISOLATOR SETTINGS RECORD	141

FIGURES

Figure 1	Recommended derating for high altitude operation	7
Figure 2	Maximum ambient temperature for full load operation at higher altitudes.	7
Figure 3	Typical static transfer switch one-line diagram	9
Figure 4	Typical one-line diagram of two PDUs and a static transfer switch	11
Figure 5	Outline drawing: 100 – 250 amp STS2	17
Figure 6	Outline drawing: 400 – 600 amp STS2	18
Figure 7	Outline drawing: 800 – 1000 amp STS2	19
Figure 8	Outline drawing: 100 – 250amp STS2 with a key lockout switch option	20
Figure 9	Outline drawing: 400 – 600 amp STS2 with a key lockout switch option	21
Figure 10	Outline drawing: 800 – 1000 amp STS2 with the key lockout switch option	22
Figure 11	Seismic anchor drawing: 100 – 250 amp STS2	23
Figure 12	Seismic anchor drawing: 400 – 600 amp STS2	24
Figure 13	Seismic anchor drawing: 800 – 1000 amp STS2	25
Figure 14	Electrical field connections drawing: 100 – 250 amp STS2 with single output breaker.	26
Figure 15	Electrical field connections drawing: 100 – 250 amp STS2 with dual output breakers	27
Figure 16	Electrical field connections drawing: 400 – 600 amp STS2 with single output breaker.	28
Figure 17	Electrical field connections drawing: 400 – 600 amp STS2 with dual output breakers	29
Figure 18	Electrical field connections drawing: 800 – 1000 amp STS2 with single output breaker.	30
Figure 19	Electrical field connections: 800 – 1000 amp STS2 with dual output breakers	31
Figure 20	Circuit breaker schedule.	32
Figure 21	Control connection location diagram: 100 – 600 amp STS2	33
Figure 22	Control connection location diagram: 800 – 1000 amp STS2	34
Figure 23	Control wiring for remote source selection option.	35
Figure 24	Control wiring for the programmable relay board option.	36
Figure 25	Control wiring for the input contact isolator board option.	37
Figure 26	Control wiring for comms board (see Figure 27 on page 39 for internal modem wiring)	38
Figure 27	Control wiring for the internal modem option	39
Figure 28	Control wiring for the network interface card (NIC) option.	40
Figure 29	Control wiring for the RS-232 port	41
Figure 30	Outline drawing for input junction box	42
Figure 31	Color LCD touch screen display	43
Figure 32	LED display	44
Figure 33	Installation drawing, seismic floor stand 100-250A	45
Figure 34	Installation drawing, seismic floor stand 100-250A	46
Figure 35	Installation drawing, seismic floor stand 100-250A	47
Figure 36	Installation drawing, seismic floor stand 100-250A	48
Figure 37	Installation drawing, seismic floor stand 400-600A	49
Figure 38	Installation drawing, seismic floor stand 400-600A	50
Figure 39	Installation drawing, seismic floor stand 400-600A	51
Figure 40	Installation drawing, seismic floor stand 400-600A	52
Figure 41	Installation drawing, seismic floor stand 800-1000A	53
Figure 42	Installation drawing, seismic floor stand 800-1000A	54
Figure 43	Installation drawing, seismic floor stand 800-1000A	55
Figure 44	Installation drawing, seismic floor stand 800-1000A	56
Figure 45	STS2 touch screen display	59
Figure 46	STS2 touch screen display	65
Figure 47	Source transfer screen	66
Figure 48	Gate board viewing slot locations.	68
Figure 49	STS2 touch screen display	85
Figure 50	Menus	86
Figure 51	Keyboard and keypad displays.	86
Figure 52	Key lockout switch.	87

Figure 53	Event mask dialog box	89
Figure 54	User settings dialog box	90
Figure 55	Source setpoints	91
Figure 56	Comm options dialog box	93
Figure 57	Modem dialog box	94
Figure 58	Input contact isolator dialog box	96
Figure 59	Programmable relay board dialog box	98
Figure 60	System options	99
Figure 61	Event log	101
Figure 62	History log	101
Figure 63	LED display	103
Figure 64	Key lockout switch.	105

TABLES

Table 1	Heat Output	6
Table 2	Altitude conversion—feet to meters.	7
Table 3	Input/output conduit plate specifications	10
Table 4	Input junction box dimensions	10
Table 5	Input junction box terminal wire size range	10
Table 6	Remote source selection terminal block.	12
Table 7	Terminal block 1 and terminal block 2 wire connections	12
Table 8	Programmable relay board pinout	13
Table 9	Event Messages.	74
Table 10	Terminal Commands	77
Table 11	Value types	79
Table 12	Group settings and values	79
Table 13	Binary-Hexadecimal Conversions	82
Table 14	Set Point Parameters	91
Table 15	Standard Settings for Programmable Relays	97
Table 16	LED and push button description	104
Table 17	Input/Output Voltage	110
Table 18	System Current Ratings.	110
Table 19	Electrical Requirements	111
Table 20	Unit Short Circuit Withstand Capability	111
Table 21	Frame Sizes	112
Table 22	MTA Plug Pinout	114
Table 23	DB9 Pinout	114
Table 24	RS-232 Settings.	115
Table 25	Torque tightening	137

IMPORTANT SAFETY INSTRUCTIONS

Save these instructions

This manual contains important instructions that should be followed during the installation and maintenance of the Liebert Static Transfer Switch 2 (STS2).



WARNING

The unit is supplied by more than one power source. The Unit contains hazardous voltages if any of the input sources are ON, even when the unit is in bypass. To isolate the unit, turn OFF and lock out ALL input power sources.

Verify that all input power sources are de-energized and locked out before making connections inside unit.

Lethal voltages exist inside the unit during normal operation. Only qualified service personnel should perform maintenance on the static switch.



NOTE

Read the entire manual before installing or operating the system. Adhere to all operating instructions and warnings on the unit and in this manual.

Liebert Corporation neither recommends nor knowingly sells this product for use with life support or other FDA-designated "critical" devices.

The Static Transfer Switch is suitable for indoor use only. Protect the unit from excessive moisture and install the unit in an area free from flammable liquids, gases, or corrosive substances.

The unit is designed to operate from solidly grounded AC power sources only. Provide input over-current protection in accordance with the unit ratings. Wire and ground the unit according to national and local electrical safety codes. All wiring should be installed by a qualified electrician.

Before unit is placed into service for the first time, after equipment relocation, or after the unit has been de-energized for an extended period of time, a thorough equipment inspection and supervised start-up by qualified service personnel are strongly recommended.



CAUTION

This unit complies with the limits for a Class A digital device, pursuant to Part 15 Subpart J of the FCC rules. These limits provide reasonable protection against harmful interference in a commercial environment. This unit generates, uses and radiates radio frequency energy and, if not installed and used in accordance with this instruction manual, may cause harmful interference to radio communications. Operation of this unit in a residential area may cause harmful interference that the user must correct at his own expense.



WARNING

Locate the center of gravity symbols  and determine the unit's weight before handling the cabinet.

OVERVIEW OF MANUAL

The STS2 Installation, Operation and Maintenance Manual is organized in a logical progression so that you can follow the procedures, in the order provided to get your STS2 installed and running.

Read the entire manual before proceeding with the unpacking and installation of the STS2.

The major sections are as follows:

Important Safety Instructions—review the instructions on the previous page before proceeding.

Support Information—a blank table in which you can enter pertinent data, such as the serial and part numbers, which is needed when calling Liebert support.

Programmable Relay Board Settings Record—a blank table in which you can document your Programmable Relay Board settings.

Input Contact Isolator Settings Record—a blank table in which you can document your Input Contact Isolator settings.

1.0 - Safety Precautions—provides safety warnings that you must review before proceeding.

2.0 - Unpacking and Inspections—provides instructions for inspecting, unloading, handling and removing the STS2 from the shipping pallet.

3.0 - Location Considerations—provides information regarding environmental considerations for where the STS2 is installed.

4.0 - Locating the STS2—provides instructions for leveling the STS2 and anchoring the unit to the floor, should that be required.

5.0 - Power and Control Wiring—provides instructions wiring the STS2 for power and control connections.

6.0 - Options—lists the options available for the STS2.

7.0 - Installation Drawings—provides outline, seismic and electrical field connection drawings required for installing the STS2.

8.0 - Introduction to STS2 Operations—provides a system description.

9.0 - Theory of Operation—provides an overview of how the unit works, plus a brief overview of some of the components.

10.0 - Operating Instructions for the Touch Screen Interface—provides instructions for turning the system on and off, completing a maintenance by-pass, and selecting a preferred source.

11.0 - Alarm and Faults—provides a list of event messages.

12.0 - Communication Interfaces—discusses the communication ports and provides a list of terminal and modem commands.

13.0 - STS2 Touch Screen Display—provides instructions for using the HMI touch screen interface for monitoring and managing the STS2.

14.0 - Operating the LED Display STS2—provides instructions for operating the LED Display unit without the touch screen display.

15.0 - Specifications—provides specifications for the STS2.

16.0 - Event Message Help Text—provides the help text for the various system event messages. This help is also available through the touch screen interface.

17.0 - Maintenance—briefly discusses routine maintenance, provides proper torque settings for nuts and bolts, and provides the Liebert contact information.

1.0 SAFETY PRECAUTIONS

Read this manual thoroughly before working with the static transfer switch.

Be sure to review the warning under **Important Safety Instructions on page 1**.

Refer to the **Handling Considerations on page 5** before attempting to move the unit.

Under typical operation and with the doors closed, only normal safety precautions are necessary. The area around the static transfer switch should be kept free from puddles of water, excess moisture and debris. The vent grate in the front of the system should not be obstructed in order to ensure a smooth air flow through the unit for cooling.

ONLY qualified service personnel should perform maintenance on the static transfer switch. When performing maintenance on any part of the equipment under power, service personnel and test equipment should be located on rubber mats. The service personnel should wear insulating shoes for isolation from direct contact with the floor.

Unless all power is removed from the input sources to the unit, one person should never work alone. A second person should be on hand to assist and summon help, should an accident occur.

Three types of messages are used throughout this manual to stress important text. Carefully read the information below each Warning, Caution and Note and use professional skills and prudent care when performing the actions described in that text.

A Warning indicates the presence of a possible serious, life-threatening condition. For example:



WARNING

The unit is supplied by more than one power source. The Unit contains hazardous voltages if any of the input sources is ON, even when the unit is in bypass. To isolate the unit, turn OFF and lock out ALL input power sources.

Verify that all input power sources are de-energized and locked out before making connections inside unit.

Lethal voltages exist inside the unit during normal operation. only qualified service personnel should perform maintenance on the static switch.

A Caution indicates a condition that could seriously damage the equipment and possibly injure personnel. For example:



CAUTION

Risk of unit damage

The input sources to the static switch must be grounded-wye sources. input sources other than solidly grounded-wye sources may cause damage to the switch.

A Note emphasizes important text. If the instructions are not properly followed, the equipment could be damaged or may not properly operate. For example:



NOTE

Read the entire manual before installing and operating the unit.

2.0 UNPACKING AND INSPECTIONS

**NOTE**

Read the entire manual before installing and operating the unit. Upon receipt of the Static Transfer Switch², the installer should perform the following steps to assure a high-quality installation.

A high-quality installation begins on the receiving dock. The STS2 and its packaging should be inspected when the unit is delivered. If the packaging is not damaged, unpack the unit and conduct an internal inspection before beginning the installation process. This section discusses the inspecting and unpacking of the STS2.

2.1 External Inspections

1. While the STS2 is still on the truck, inspect the equipment and shipping container(s) for any signs of damage or mishandling. Do not attempt to install the system if damage is apparent.
2. Upon receipt and before unpacking, inspect the shipping crate for damage or mishandling. Check the Shock-Watch™ indicator.
 - If the indicator is red, note on shipper's receipt and check for concealed damage.
 - If any damage as a result of shipping is observed, file a damage claim with the shipper within 24 hours and contact your local Liebert representative or Liebert Global Services at 1-800-543-2378 to inform them of the damage claim and the condition of the equipment.
3. Locate the bag containing the keys for the front access door. The bag is attached to the cabinet.
4. Compare the contents of the shipment with the bill of lading. Report any missing items to the carrier and to Liebert Global Services immediately.
5. Check the nameplate on the cabinets to verify that the model numbers correspond with the one specified. Record the model numbers and serial numbers in the front of this installation manual. A record of this information is necessary should servicing be required.
6. If unit is to be stored before installation, it is recommended to store the unit in a dry environment with temperatures in the range of -40°F (-40°C) to 176°F (80°C). Use original packing materials or other suitable means to keep the unit clean. When opening the shipping crate, use care not to puncture the container with sharp objects.

2.2 Unloading and Handling

**CAUTION**

Risk of unit damage.

When moving the unit by forklift, lift the unit from the rear so as to protect the front panel.

Do not exceed a 15 degree tilt with the forklift.

Also, if you are moving the unit by forklift or pallet jack after it has been removed from the pallet, be aware of the location of the casters and leveling feet so as not to damage them.

Most STS2 models are contained in one cabinet. The 800–1000 amp units are contained in two cabinets that are connected together and shipped on one pallet.

Because the weight distribution in the cabinet is uneven, use extreme care during handling and transporting.

The unit can be moved by forklift or pallet jack.

See **2.2.2 - Unit Preparation** on page 5 for instruction on removing the STS2 from the pallet.

2.2.1 Handling Considerations

The static switch is bolted to a wooden shipping pallet to allow handling by forklift equipment or a pallet jack.

Easily Moved — The unit is furnished with integral castors that allow the unit to be rolled into place after it has reached its location and is removed from the pallet.



WARNING

Exercise extreme care when handling static switch cabinets to avoid equipment damage or injury to personnel.

The cabinet can be safely tilted 15 degrees in any direction by forklift.

If moving the unit up a ramp on its casters or a pallet jack, ensure that the incline does not exceed fifteen (15) degrees.

Locate the center of gravity symbols  and determine the unit's weight before handling the cabinet.

Check the unit size and weight — Refer to the cabinet drawings furnished with the unit for size and weight. Typical cabinet dimensions are shown in **Figures 5** through **7**. Typical unit weights are:

100-250 amp	780 lbs. (354 kg)
400-600 amp	1200 lbs. (544 kg)
800-1000 amp	2500 lbs. (1134 kg).

Plan the route — Review the route over which the unit will be transported to its installation location to ensure that all passages are large enough to accommodate the unit and support the weight. Check for any non-negotiable corners or offsets in hallways. Before moving the unit to the intended location, review **3.0 - Location Considerations**.

2.2.2 Unit Preparation

The unit can be removed from the pallet before it is moved to its location.

Complete the following steps to properly remove the STS2 from the shipping pallet:

1. Set the pallet in a level area with enough room to maneuver and remove the unit.
2. Remove the bolts holding the unit to the shipping pallet (located in the base of the unit).
3. Remove the shipping blocks from under the frame of the unit.
4. Use a forklift to raise the unit off the pallet and onto the floor. *Ensure that the forklift is clear of the unit's casters and leveling feet. Lift the unit from the rear.*
5. Conduct an internal inspection of the unit. See the list below of inspection items.

2.3 Internal Inspections

After the STS2 has been unpacked, conduct an internal inspection:

1. Verify that all items have been received.
2. If spare parts were ordered, verify their arrival.
3. After the Static Transfer Switch has been removed from the pallet, open the door and remove cabinet panels to check for shipping damage to internal components.
4. Check for loose connections or unsecured components in the cabinet(s).
5. Check for any unsafe condition that may be a potential safety hazard.

After the STS2 has been inspected and no problems are found, the unit can be moved to its installation location. If using a forklift, remember to lift the unit from the rear.

3.0 LOCATION CONSIDERATIONS

The STS2 should be placed in a clean, cool and dry location. The STS2 requires only front access for installation and maintenance. Back or side access is not required. Adequate space is required above the unit for conduit (if configured as such) and cooling air flow. This section provides specific information for these considerations.

The unit is designed with top and bottom cable terminations to allow maximum flexibility in its installation. If bottom cable entry is used, sufficient cable bending space must be provided by a raised floor or a floor stand.

For dimensions of each unit, see **Figures 5, 6 and 7** in section **7.0 - Installation Drawings** on page 17. If your unit is equipped with an optional key lockout switch, see **Figures 8 through 10** for location of that switch.

3.1 Recommended Minimum Service Clearances

The recommended service clearances are at the front of the unit. The minimum service clearance required by the National Electrical Code (NEC) Article 110-26 is 36 in. (91 cm) for units with voltages up to 150 volts to ground and 42 in. (107 cm) for units with voltages over 150 volts to ground. Clearance of at least 18 in. (46 cm) is required above the unit for cooling air flow.

3.2 Heat Output

The unit produces minimal heat during normal operation.

Table 1 Heat Output

Switch Size	Heat Output BTU/Hr (kW)
100 amp	2,711 (0.80)
250 amp	4,680 (1.37)
400 amp	6,972 (2.04)
600 amp	10,520 (3.08)
800 amp	13,777 (4.03)
1000 amp	17,390 (5.09)

3.3 Operating Environment

The unit is designed to be installed indoors where the ambient air temperature is in the range of 32° and 104°F (0°C and 40°C) with a relative humidity of 0% to 95% non-condensing, up to an altitude of 4000 feet (1200 meters).

3.4 Altitude

The standard units are designed for full load operation up to 4000 feet (1200 m) above sea level. See **Figure 1** for recommended deratings for altitudes greater than 4000 feet (1200 m).

Figure 1 Recommended derating for high altitude operation

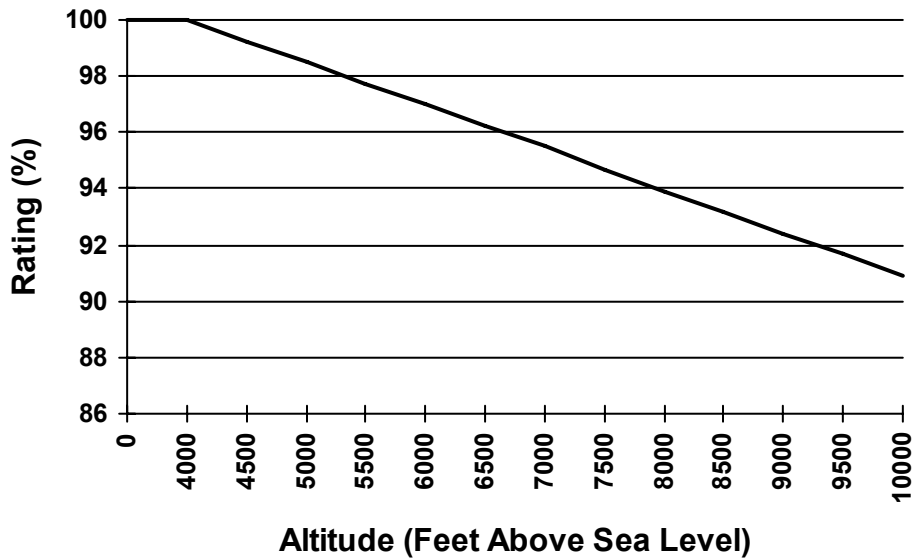

Operation at full load at a higher altitude can be accommodated in ambient temperatures less than 104°F (40°C) ambient. **Figure 2** shows the maximum allowable ambient temperature for full load operation at altitudes above 4000 feet (1200 m).

Figure 2 Maximum ambient temperature for full load operation at higher altitudes

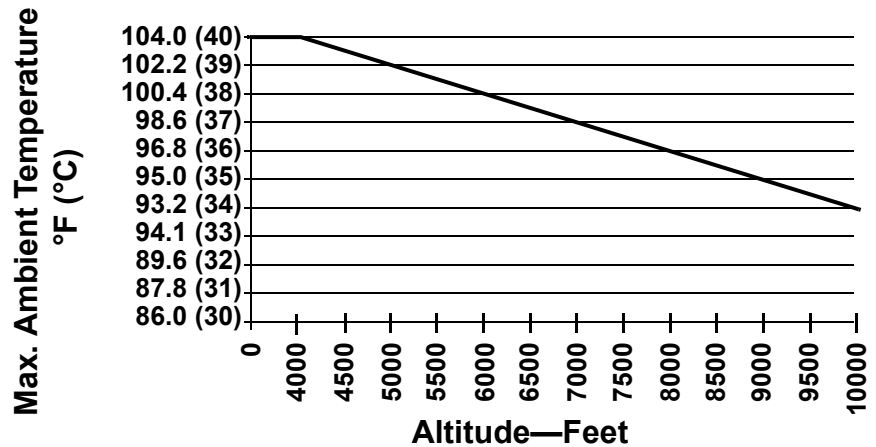

Table 2 Altitude conversion—feet to meters

Altitude	Feet	Meters	Altitude	Feet	Meters
		4000		1200	
	4500	1372		8000	2438
	5000	1524		8500	2591
	5500	1676		9000	2743
	6000	1829		9500	2896
	6500	1981		10000	3048
	7000	2134			

4.0 LOCATING THE STS2

This section provides instructions for leveling the STS2 and anchoring the unit to the floor, should that be required.

For leveling feet details, see **Figures 5** through **10**.

4.1 Leveling and Anchoring the Unit to the Floor

The STS2 can be anchored to the concrete floor to ensure stability for the unit in the event of seismic activity.

The seismic brackets are an option for the STS2 and are shipped separately from the unit when ordered.

See **Figures 11** through **13** for instructions and details for installing seismic anchoring.

4.2 Leveling of the Static Switch Without Anchoring

The Static Transfer Switch is furnished with casters and leveling feet. After final positioning of the unit, adjust the leveling feet located in each corner of the frame base to level and stabilize the unit.

4.3 Leveling and Anchoring the Static Switch Using Floor Stand

The STS2 can be installed using the optional floor stand to support the unit instead of using the raised floor. The STS2 can be rolled or placed using a lift on to the floor stand.

After final positioning of the unit, adjust the leveling feet located in each corner of the frame base to level and stabilize the unit.

The floor stand can also be used to ensure the unit's stability in the event of seismic activity by anchoring the STS2 to the floor stand and to the concrete floor .

The seismic floor stand is shipped separately from the unit when ordered.

See **Figures 33** through **44** for instructions and details for installing seismic floor stand.

5.0 POWER AND CONTROL WIRING

All power and control wiring should be installed by a qualified electrician. All power and control wiring must comply with the NEC and applicable local codes. Unless otherwise labeled, use the recommended tightening torque as shown in **Table 25 - Torque tightening**.

The busbars are accessible through the front of the STS2 and designed to allow one-handed tightening. Cables can be installed through the top or bottom of the unit through removable conduits plates.

See **Figures 5 through 10** for wiring entrance locations.

Input wiring also can be installed under a raised floor to optional input junction boxes and cables, when used.

5.1 Input And Output Power Connections

If the unit is furnished with input junction boxes, the input power connections are made to the input power terminals located in the junction boxes. Input power cables, furnished with the input junction boxes, are shipped unattached to the unit for connection between the junction boxes and the bus bars provided inside the unit. Input junction box installation is discussed in **5.2 - Input Junction Box Installation (Optional)** on page 10.

If input junction boxes are not furnished, the input power connections are made to the bus bars provided inside the unit. These bus bars are accessible through the front of the unit.

Output power connections also are made to the bus bars provided inside the unit. These bus bars are accessible through the front of the unit. See **Figures 14 to 19** for details on the bus bars.

WARNING

Risk of electric shock

Verify that all input power and control circuits are de-energized and locked out before making connections inside unit.

The two input power feeds (sources) to the STS2 should be from two independent sources to avoid a common source failure.

To ensure proper operation of the STS2, the two input sources must be the same nominal voltage level and phase rotation.

For uninterrupted automatic transfer, the two input sources should be synchronized within 15 degrees.

CAUTION

Risk of unit damage.

The input sources to the static switch must be grounded-wye sources. Input sources other than solidly grounded-wye sources may cause damage to the switch.

The STS2 is designed for operation with 3 or 4-wire solidly grounded sources only.

For 4-wire operation, the common source neutral must be connected to the STS2. See **Figure 3** on page 9 for a typical one-line diagram. Refer to **Figures 14 to 19** for electrical field connections on all units, with both single and dual output breakers.

Figure 3 Typical static transfer switch one-line diagram

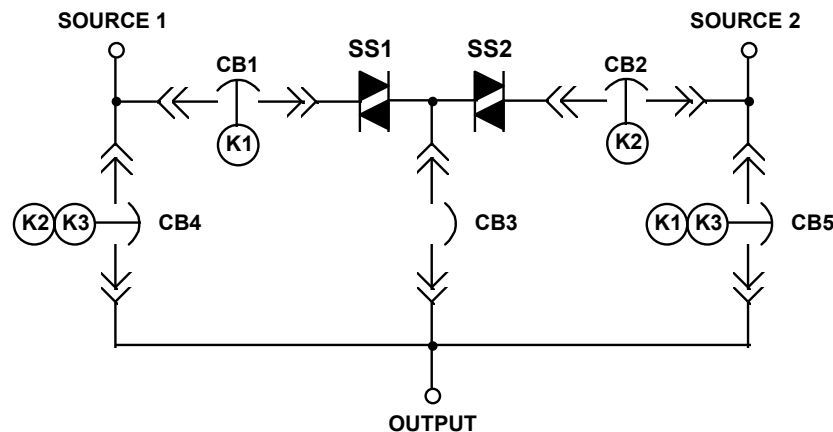

The input and output power wire size should be based on the upstream overcurrent protection device, observing the NEC and local codes.

The molded case switches contained in the STS2 are typically non-automatic circuit breakers that rely on the upstream and/or load overcurrent protection. Upstream overcurrent protection should be rated equal to or less than the rating of the STS2 molded case switches.

The STS2 input and output power and ground and neutral bus bars accommodate a wide range of wire sizes. The STS2 bus bars accommodates standard 2 hole lugs.

Table 3 Input/output conduit plate specifications

Rating	Max. number and size
100-250A	6 — 3" conduit
400-600A	9 — 4" conduit
800-1000A	12 — 4" conduits

5.2 Input Junction Box Installation (Optional)

The input junction box option is available to simplify input connections to the STS2. Two input junction boxes and the associated flexible 10 foot long (3 meter) input cables are provided with this option.

This option is available only with bottom cable entrance, typically when the unit is located on a raised floor.

If the input junction boxes will be used, they either can be shipped with the unit or shipped in advance to be installed during the rough-in stage of construction.

Locate the junction boxes a maximum of 8 feet (2.4 meters) from the planned location of the Static Switch.

Due to a lack of clearance for the cables below the unit, the cables are also shipped loose from the unit for installation at the site. The input cables connect from the input junction boxes to the input power bus bars inside the STS2.

The standard configuration for the input junction boxes and cables is for 3-wire-plus-ground feeds. If the input neutral is required, special 4-wire-plus-ground input cables and junction boxes are required. See **Figure 30** for wiring details.

For preparation purposes, the following tables provide the dimensions and wire sizes for the input junction boxes.

Table 4 Input junction box dimensions

Switch Rating	Length Inches (mm)	Width Inches (mm)	Height Inches (mm)
100 amp	16 (406)	14 (356)	6 (152)
250 to 600 amp	30 (762)	16 (406)	6 (152)

Table 5 Input junction box terminal wire size range

Switch Rating	Power and Ground Lug Wire Range
100 amp	#6 to #2/0 AWG
250 to 600 amp	(2) #6 AWG to (2) 500 kcmil

5.3 System Grounding

Equipment grounding — Grounding is primarily for equipment and personnel safety, although proper grounding also enhances equipment performance.

All input and output power feeds must include an equipment grounding means as required by the NEC and local codes.

An insulated equipment ground conductor is recommended to run with each input and output power feed. The equipment ground conductors should be at least the minimum size conductor per the NEC based on the upstream overcurrent protection device.



WARNING

If conduit is used as a grounding means, adequate electrical continuity must be maintained at all conduit connections. The use of isolating bushings with a metal conduit can be a safety hazard and is not recommended.

4-Wire-Plus-Ground Systems — When 4-wire-plus-ground input feeds are utilized, the input power sources must be properly grounded. Because the neutral is not switched by the STS2, the neutrals of the two power sources are solidly interconnected. The NEC prohibits grounding a power source at more than one point. Connecting the neutrals of two grounded power sources together effectively grounds each of the sources at more than one point, which allows neutral current to flow on the ground system, defeats ground fault protection, creates a safety hazard, and violates the NEC.

Where possible, **the two power sources should be located in close proximity and a single neutral-to-ground bond made** (as shown in Figure 4 on page 11 or as is typical with a double-ended substation).

Figure 4 Typical one-line diagram of two PDUs and a static transfer switch

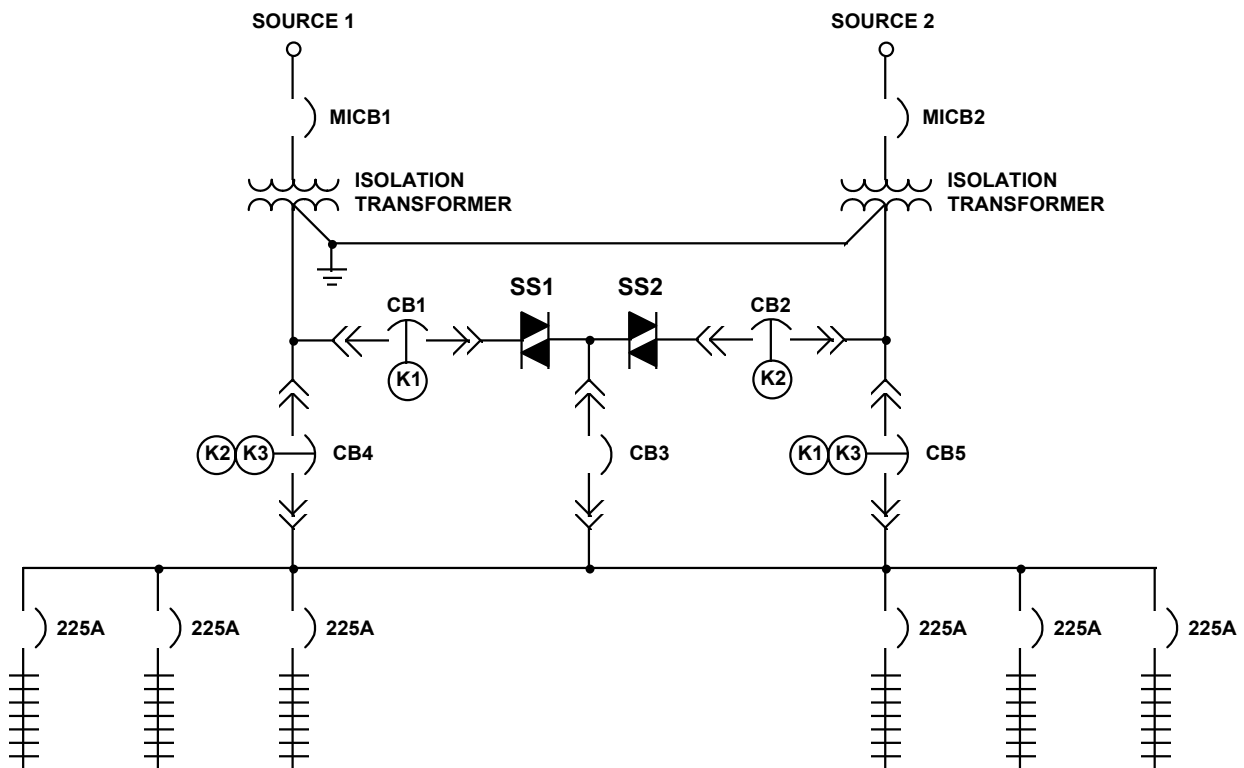

5.4 Control Wiring Connections

No control wiring is needed on the standard STS2. Only certain options require external control wiring. See 6.0 - Options on page 13 for details

5.5 Remote Source Selection Wiring

An optional Remote Source Selection board may be installed in your STS2. This board is installed in the same bay as the communications options. See **Figures 21** and **22** for the location of these options. See **Figure 23** for information on the control wiring for the Remote Source Selection option.

The Remote Source Selection allows you choose the preferred input source from a remote location. Terminal connections allow the customer to remotely select a source to be the preferred source in the same process as the local source transfer selection.

The unit's preferred source selection and Remote Source Selection are active at the same time, with the STS2 following the last request for a preferred source change, regardless of whether it was from the local or Remote Source Selection controls.

A six pin terminal block provides the Remote Source Selection connections. Two pairs of wires are used from the switch to trigger the source selection. You can select the type of switch used for this remote control. Connections are made to four of the connections, using Form A dry contacts. The contacts are numbered left to right:

Table 6 Remote source selection terminal block

Contact	Connection
1	Source 1
2	Isolated ground
3	Source 2
4	Isolated Ground
5	DO NOT USE
6	DO NOT USE

See **10.3 - Enabling Remote Source Selection** for instructions on enabling the Remote Source Selection option.

5.6 Power Supply

The STS2 is supplied with redundant power supplies that are designed to operate from a voltage range of 200V to 600V. The unit is set at the factory to match the nameplate voltage. Field adjustments are *not* necessary. If the unit needs to operate at a voltage other than what is listed on the nameplate, contact Liebert Global Service or the local Liebert representative. **Table 7** provides transformer tap information.

Table 7 Terminal block 1 and terminal block 2 wire connections

Voltage	Connect t		Connect		Jumper Between
	F1 TB1-XX	F2 TB1-YY	F3 TB2-XX	F4 TB2-YY	
200	1	9	1	9	1-7
208	1	10	1	10	1-7
220	2	12	2	12	6-8
240	1	11	1	11	1-7
380	1	8	1	8	2-7
400	1	9	1	9	3-7
415	1	10	1	10	4-7
480	1	11	1	11	5-7
600	1	12	1	12	6-7



CAUTION

Using **Table 7**, ensure that the wiring for the control transformers matches the input voltage for the unit.

Improper wiring could result in blown fuses.

6.0 OPTIONS

This section discusses the options available for the STS2. The communications options are also discussed in **12.0 - Communication Interfaces**.

6.1 Programmable Relay Board

The Programmable Relay Board (PRB) provides a means to trigger an external device when an event occurs in the STS2. Each PRB has 8 channels. Each channel has two sets of Form-C dry contacts, rated 1 Amp @ 30 VDC or 250 mAmp @ 125 VAC.

Any alarm/event can be programmed to any channel or channels. Up to ten (10) events can be programmed to a relay. If multiple events are grouped to one relay, group the events logically to simplify troubleshooting when an event is triggered. The same alarm/event can be programmed to more than one channel. Up to two Programmable Relay Boards can be installed in the STS2 for a total of 16 channels. Programming is performed through the touch screen display.

See **Configuring the Programmable Relay Board Settings on page 97** for default settings and instructions for reconfiguring the relays. See **Figures 21** and **22** for the location of the PRB. See **Figure 24** for wiring details. **Table 8** provides the PRB pinout.

Table 8 Programmable relay board pinout

	Channel	Pin No.	C	N.C.	N.O.	
TB1	CH1	A	1-3	1	2	3
		B	4-6	4	5	6
	CH2	A	7-9	7	8	9
		B	10-12	10	11	12
TB2	CH3	A	13-15	13	14	15
		B	1-3	1	2	3
	CH4	A	4-6	4	5	6
		B	7-9	7	8	9
	CH5	A	10-12	10	11	12
		B	13-15	13	14	15
TB3	CH6	A	1-3	1	2	3
		B	4-6	4	5	6
	CH7	A	7-9	7	8	9
		B	10-12	10	11	12
TB4	CH8	A	13-15	13	14	15
		B	1-3	1	2	3

Key: N.O. = Normally Open; N/C. = Normally Closed; C = Common
Note: Pin 16 not used on TB1, TB2, and TB3.

6.2 Optimized Transfer

When the STS2 is used as a primary-side switch—on the primary of an isolation transformer—optimized transfer greatly reduces the transformer magnetization current during automatic transfers through a new transfer control algorithm. The Liebert algorithm (patent pending) optimizes the transfer timing so that the volt-seconds applied to the downstream transformer primary is balanced, minimizing peak saturation current.

The volt-second balance is achieved by directly computing the volt-second applied to the transformer during transfer events and determining the optimum time to turn on the alternate source SCRs in order to balance the volt-second within specified tolerance.

Optimized transfer also seeks to minimize the voltage disturbances while still maintaining transformer flux balance. This unique flux balance algorithm does not just wait for the balance point to occur, but will pulse fire the SCRs as soon as possible to minimize the voltage disruption. This results in far superior voltage waveforms applied to the load.

6.3 Distribution Cabinet With I-Line Panelboard—100-600A Units Only

A distribution cabinet with a Square D I-Line panelboard offers space to plug in up to 10 three-pole branch circuit breakers (100A-250A). The panelboard is rated at 600A with an overall short-circuit rating of 100,000 AIC.

The full-height cabinet mounts on either the right or left side of the STS2 and is fully enclosed with a keylock door and an accent cover that permits access to the panelboard without exposing other portions of the STS2.

6.4 Input Contact Isolator Board

The Input Contact Isolator Board (ICI) provides an STS2 module interface for up to eight external user alarm or message inputs to be routed through the static transfer switch's alarm network. The eight contacts are normally open dry contacts. When a contact closes, an event is triggered.

The Input Contact Isolator options are configured through the Input Contact Isolator dialog box, which is accessed from the Comm Option dialog box on the touch screen display. You also can program the alarm messages through this dialog box. See **Configuring the Input Contact Isolator Settings on page 95** for instructions on configuring the connections.

See **Figures 21** and **22** for the location of the ICI. See **Figure 25** for wiring details.

6.5 Comms Board

The Comms Board provides a communication interface to Liebert SiteScan, site monitoring product, and/or an external or internal modem. SiteLink-12 or SiteLink-4 is required for SiteScan to communicate with the STS2.

The Comms Board is equipped with an RS-422 communication port for communication to a Liebert SiteScan monitoring system using a 2-wire twisted pair for reliable communication up to 1000 meters (3281 feet). Information available from the RS-422 port includes the present switch status information, all monitoring parameters, and all active alarms.

The Comms Board is equipped with a modem interface for remote reporting of the present switch status information, alarm history information, and the history of status screens that are triggered upon a major alarm event. The monitoring system software also supports an auto-dial feature that allows the system to automatically dial programmed phone numbers by way of the modem to report designated alarm conditions.

Programming the Comms Board is performed through the touch screen display. See **Comm Options on page 93** for details.

See **Figures 21** and **22** for the location of the Comms Board.

See **Figure 26** for information on the control wiring.

6.6 Internal Modem

The Internal Modem is an option that must be ordered separately. An external modem is available from third party sources. The Internal Modem is capable of dialing out from the STS2 or accepting incoming calls and connecting to a remote terminal or computer. Using an ASCII Query and Answer format the modem connection can be used to view system status and alarms. The modem provides all information normally available on the LCD display of the STS2. No control functions are available via the modem, such as making transfers, selecting a preferred source, or changing configurations.

The modem can also be configured to dial out two different telephone numbers (any combination of modem or pager numbers).

The connection to this modem is through a standard RJ-11 port.

See **Figures 21** and **22** for the location of the internal modem. See **Figure 27** for more information on the internal modem.

Programming the modem is performed through the touch screen display, see **Configuring the Modem on page 94** for details.

The modem commands are shown in **Table 10**.

6.7 Network Interface Card (NIC)

An OpenComms Network Interface Card (NIC) enables the STS2 to communicate to a network management system (NMS). The NIC provides the internal hardware and software to communicate, via SNMP, to any I.P.-based Ethernet network through an RJ-45 connector using Category 5 cabling.

The NIC provides redundant paths for communications that make it possible to connect to a Building Management System (BMS) using Modbus, while simultaneously communicating to a NMS through SNMP. A terminal block provides the connection to Modbus.

See **Figures 21** and **22** for the location of the NIC.

See **Figure 28** control wiring information.

If you have questions about the NIC, refer to the OpenComms Network Interface Card Installation and Users Guide.

6.8 LED Display

A light-emitting diode display is available to replace the standard liquid crystal display touch screen control. The display provides monitoring and control through a series of LEDs and buttons. LEDs alert you when a problem occurs. A PC running terminal emulation software connected to the RS-232 port is needed to access the data and configuration settings.

6.9 Remote Source Selection

The Remote Source Selection allows the preferred input source to be chosen from a remote location. A user supplied normally open dry contact allows the user to remotely select a source to be the preferred source in the same process as the local source transfer selection.

The unit's preferred source selection and Remote Source Selection are active at the same time, with the STS2 following the last request for a preferred source change, regardless of whether it was from the local or Remote Source Selection controls.

See **10.3 - Enabling Remote Source Selection** for instructions on enabling the Remote Source Selection.

See **Figures 21** and **22** for the location of the Remote Source Selection option.

See **5.5 - Remote Source Selection Wiring** on page 12 and **Figure 23** for information on the control wiring.

6.10 Key Lockout Switch

The key lockout switch activates a software lockout of the touch screen display to prevent manual transfers and configuration changes. When locked out, the touch screen becomes a read only display. A key is needed to do manual transfers or change settings.

The alarm silence button is not disabled when in the lockout position.

The switch is located behind the front door but can be operated without opening the front door. See **Figures 8** to **10** for the key lockout location on each unit.

See **14.1.4 - Key Lockout Switch** for instructions on using the key lockout switch.

6.11 Redundant Output Breaker

An output plug-in, non-automatic circuit breaker is provided which allows redundancy in the output power path. The breaker is connected in parallel with the output plug-in non-automatic circuit breaker.

6.12 Input Junction Boxes and Cables

Two input power junction boxes and interconnecting cables provide under floor connection for the two input power feeds. Power terminal blocks are provided in each junction box for the connection of the input power conductors and a parity-sized ground conductor. The junction boxes are NEMA 1 enclosures. A main input cable assembly is provided for connection between the unit and the junction box. The cable length between the unit and junction box is 10 feet (3 meters) long.

See **5.2 - Input Junction Box Installation (Optional)** on page 10 for more information and specifications. See **Figure 30** for wiring details.

6.13 Seismic Floor Anchors

Seismic anchors are available for anchoring the unit to a concrete floor to meet seismic Zone 4 requirements. See **4.1 - Leveling and Anchoring the Unit to the Floor** on page 8 for more information. Installation details are provided in **Figures 11** through **Figure 13** on page 25.

6.14 Seismic Floor Stand

Seismic floor stands in four heights—18", 24", 30" and 36" (457mm, 610mm, 762mm and 914mm)—are available for the STS2. The stands can be fastened to the floor to meet seismic Zone 4 requirements. See **4.0 - Locating the STS2** and **Figures 33** through **44** for instructions and details for installing seismic floor stands.

7.0 INSTALLATION DRAWINGS

Figure 5 Outline drawing: 100 – 250 amp STS2

- NOTES:
1. ALL DIMENSIONS ARE IN INCHES AND MILLIMETERS.
 2. 18" (457MM) MIN. CLEARANCE ABOVE UNIT REQUIRED FOR AIR EXHAUST.
 3. INSTALLATION AND SERVICE ACCESS REQUIRED IN FRONT ONLY.
 4. HEAT OUTPUT: 2710 BTU/HR (0.80 KW/HR) MAX. FOR 100A SWITCH.
4680 BTU/HR (1.37 KW/HR) MAX. FOR 250A SWITCH.
 5. WEIGHT - 780 LBS. (354 KG).
 6. UNIT BOTTOM IS STRUCTURALLY ADEQUATE FOR FORKLIFT HANDLING.
 7. KEEP CABINET WITHIN 15 DEG. OF VERTICAL WHILE HANDLING.
 8. COLOR - IBM OFF WHITE.
 9. OPEN DOOR TO REPLACE AIR FILTER, DISPOSABLE TYPE, SIZE 1X25X25.
 10. THREADED MOUNTING HOLES (SEE DETAIL A) ARE PROVIDED FOR SEISMIC ANCHORING OR FLOOR STAND. MOUNTING BOLTS MUST BE THREADED INTO THE UNIT MOUNTING HOLES FROM UNDERNEATH THE UNIT BASE. IF FLOOR STAND IS USED, THE CASTERS MUST REST ON THE FLOOR STAND TO SUPPORT THE WEIGHT OF THE UNIT.

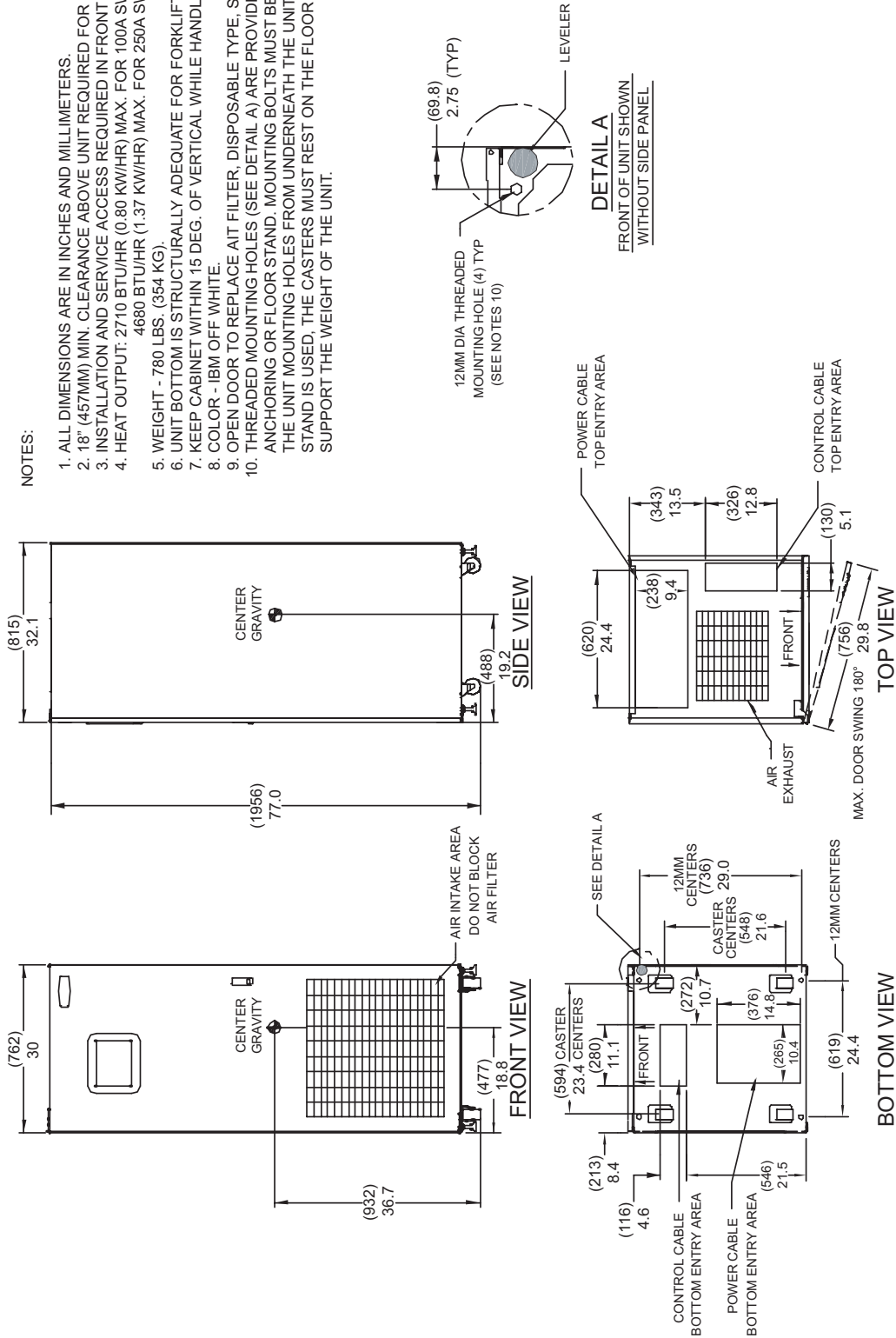

PS21100 REV. NO. 2

OUTLINE DRAWING
100 - 250 AMP
STATIC TRANSFER SWITCH 2

Figure 6 Outline drawing: 400 – 600 amp STS2

NOTES:

1. ALL DIMENSIONS ARE IN INCHES AND (MILLIMETERS).
2. 18" (457MM) MIN. CLEARANCE ABOVE UNIT REQUIRED FOR AIR EXHAUST.
3. INSTALLATION AND SERVICE ACCESS REQUIRED IN FRONT ONLY.
4. HEAT OUTPUT: 6970 BTU/HR (2.04 KW/HR) MAX. FOR 400A SWITCH.
10520 BTU/HR (3.08 KW/HR) MAX. FOR 600A SWITCH.
5. WEIGHT - 1200 LBS. (544 KG)
6. UNIT BOTTOM IS STRUCTURALLY ADEQUATE FOR FORKLIFT HANDLING.
7. KEEP CABINET WITHIN 15 DEG. OF VERTICAL WHILE HANDLING.
8. COLOR - IBM OFF WHITE.
9. OPEN DOOR TO REPLACE AIR FILTER; DISPOSABLE TYPE, SIZE 1X25X25.
10. THREADED MOUNTING HOLES (SEE DETAIL A) ARE PROVIDED FOR SEISMIC ANCHORING OR FLOOR STAND. MOUNTING BOLTS MUST BE THREADED INTO THE UNIT MOUNTING HOLES FROM UNDERNEATH THE UNIT BASE. IF FLOOR STAND IS USED, THE CASTERS MUST REST ON THE FLOOR STAND TO SUPPORT THE WEIGHT OF THE UNIT.

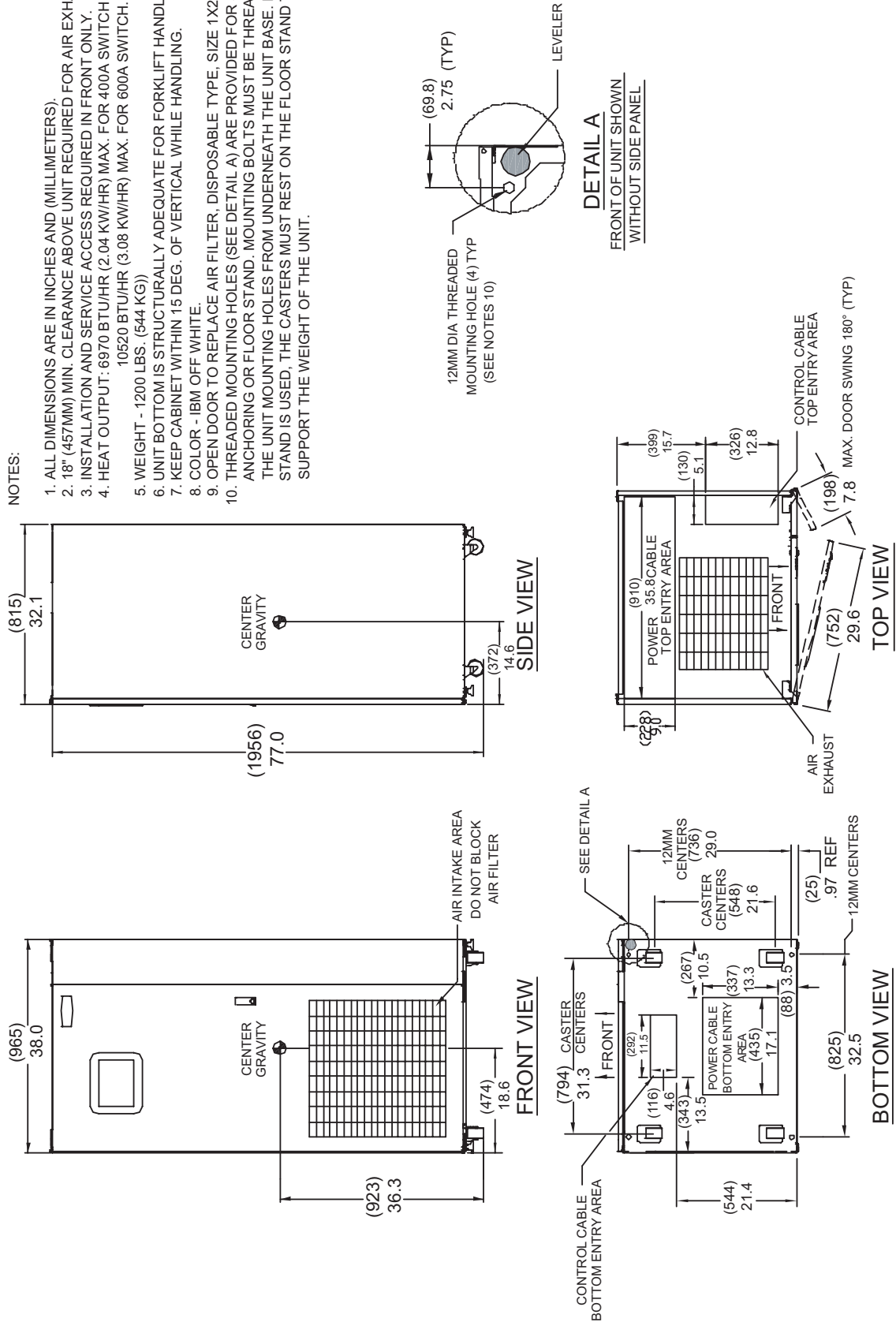

OUTLINE DRAWING
400 - 600 AMP
STATIC TRANSFER SWITCH 2

PS211400 REV. NO. 1

Figure 7 Outline drawing: 800 – 1000 amp STS2

NOTES:

1. ALL DIMENSIONS ARE IN INCHES AND (MILLIMETERS).
2. 18" (457MM) MIN. CLEARANCE ABOVE UNIT REQUIRED FOR AIR EXHAUST.
3. INSTALLATION AND SERVICE ACCESS REQUIRED IN FRONT ONLY.
4. HEAT OUTPUT: 13780 BTU/HR (4.03 KW/HR) MAX. FOR 800A SWITCH.
17390 BTU/HR (5.09 KW/HR) MAX. FOR 1000A SWITCH..
5. WEIGHT - 2500 LBS. (1134 KG)
6. UNIT BOTTOM IS STRUCTURALLY ADEQUATE FOR FORKLIFT HANDLING.
7. KEEP CABINET WITHIN 15 DEG. OF VERTICAL WHILE HANDLING.
8. COLOR - IBM OFF WHITE.
9. OPEN DOOR TO REPLACE AIR FILTER, DISPOSABLE TYPE, SIZE 1X25X25.
10. THREADED MOUNTING HOLES (SEE DETAIL A) ARE PROVIDED FOR SEISMIC ANCHORING OR FLOOR STAND. MOUNTING BOLTS MUST BE THREADED INTO THE UNIT MOUNTING HOLES FROM UNDERNEATH THE UNIT BASE. IF FLOOR STAND IS USED, THE CASTERS MUST REST ON THE FLOOR STAND TO SUPPORT THE WEIGHT OF THE UNIT.
11. 500 CFM PER FAN EXHAUST.

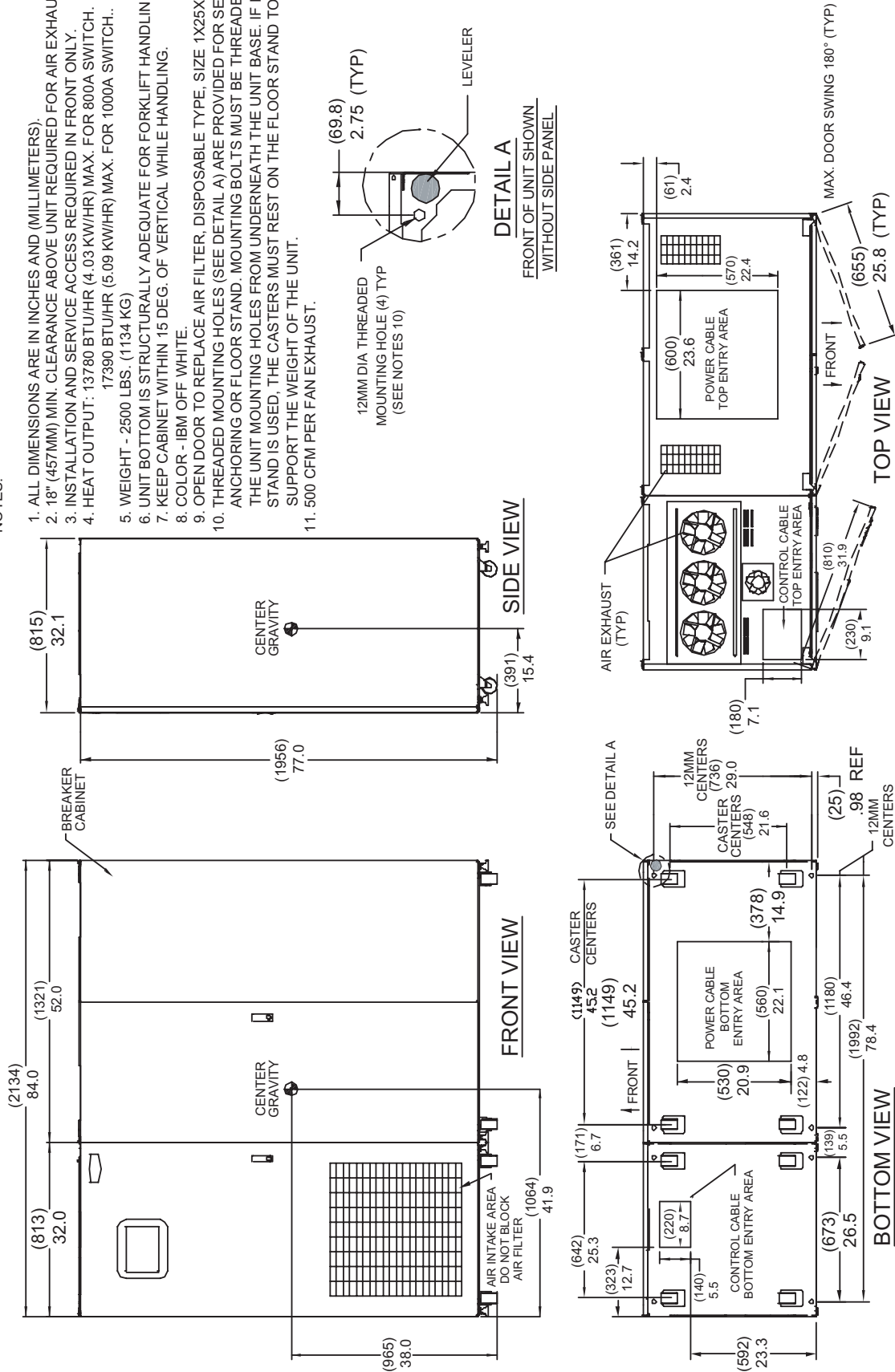

OUTLINE DRAWING
800 - 1000 AMP
STATIC TRANSFER SWITCH

PS211800 REV. NO. 1

Figure 8 Outline drawing: 100 – 250amp STS2 with a key lockout switch option

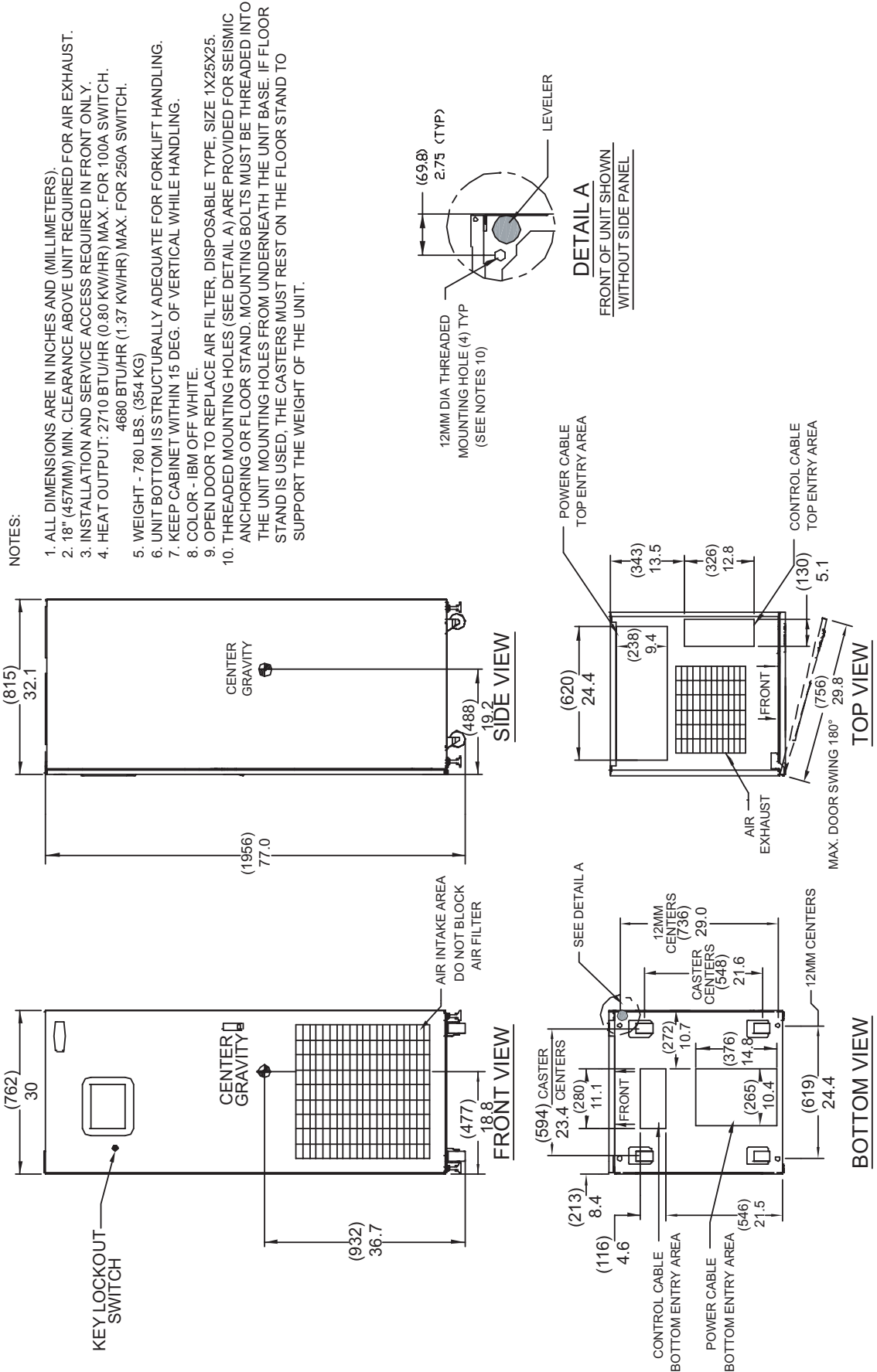

OUTLINE DRAWING
 100 - 250 AMP WITH KEY LOCKOUT SWITCH OPTION
 STATIC TRANSFER SWITCH 2

PS21101 REV. NO. 1

Figure 9 Outline drawing: 400 – 600 amp STS2 with a key lockout switch option

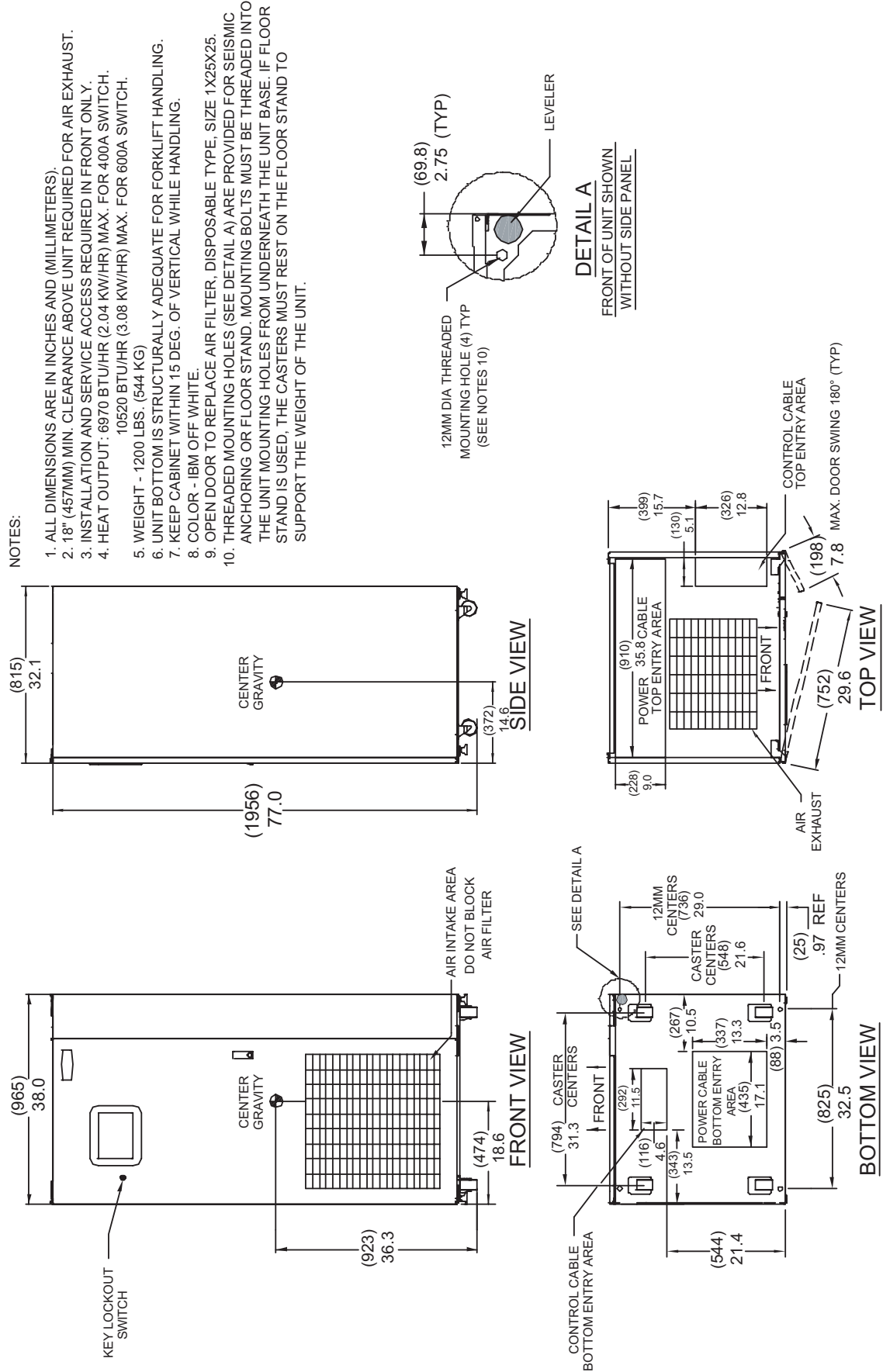

OUTLINE DRAWING
 400 - 600 AMP WITH KEY LOCKOUT SWITCH OPTION
 STATIC TRANSFER SWITCH 2

PS211401 REV. NO. 1

Figure 10 Outline drawing: 800 – 1000 amp STS2 with the key lockout switch option

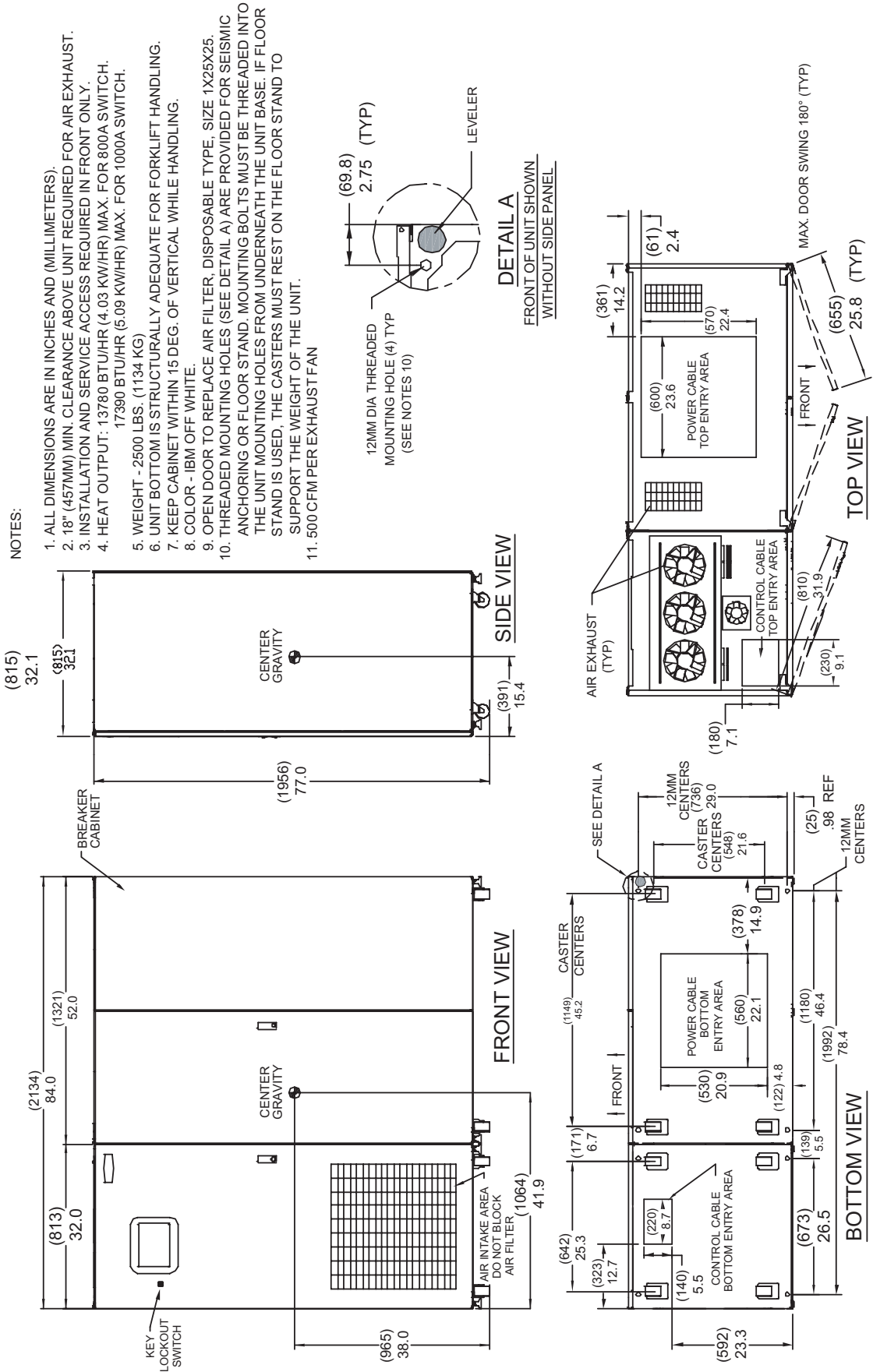

NOTES:

1. ALL DIMENSIONS ARE IN INCHES AND (MILLIMETERS).
2. 18" (457MM) MIN. CLEARANCE ABOVE UNIT REQUIRED FOR AIR EXHAUST.
3. INSTALLATION AND SERVICE ACCESS REQUIRED IN FRONT ONLY.
4. HEAT OUTPUT: 13780 BTU/HR (4.03 KW/HR) MAX. FOR 800A SWITCH.
17390 BTU/HR (5.09 KW/HR) MAX. FOR 1000A SWITCH.
5. WEIGHT - 2500 LBS. (1134 KG)
6. UNIT BOTTOM IS STRUCTURALLY ADEQUATE FOR FORKLIFT HANDLING.
7. KEEP CABINET WITHIN 15 DEG. OF VERTICAL WHILE HANDLING.
8. COLOR - IBM OFF WHITE.
9. OPEN DOOR TO REPLACE AIR FILTER, DISPOSABLE TYPE, SIZE 1X25X25.
10. THREADED MOUNTING HOLES (SEE DETAIL A) ARE PROVIDED FOR SEISMIC ANCHORING OR FLOOR STAND. MOUNTING BOLTS MUST BE THREADED INTO THE UNIT MOUNTING HOLES FROM UNDERNEATH THE UNIT BASE. IF FLOOR STAND IS USED, THE CASTERS MUST REST ON THE FLOOR STAND TO SUPPORT THE WEIGHT OF THE UNIT.
11. 500 CFM PER EXHAUST FAN

OUTLINE DRAWING
800 - 1000 AMP WITH KEY LOCKOUT SWITCH OPTION
STATIC TRANSFER SWITCH 2

PS211801 REV. NO. 1

Figure 11 Seismic anchor drawing: 100 – 250 amp STS2

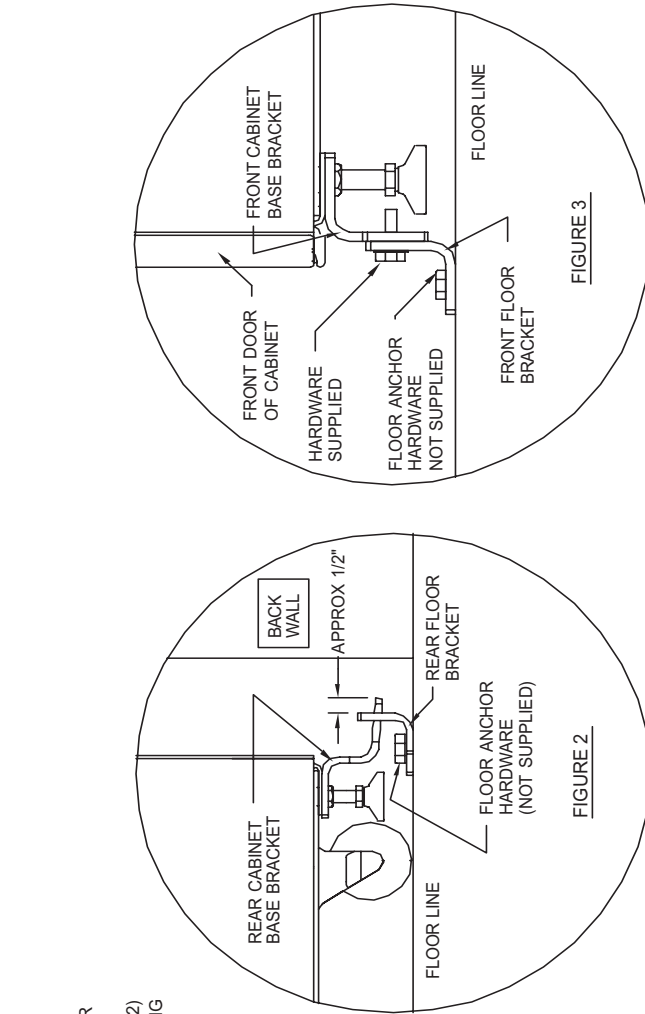

SYSTEM SEISMIC ANCHORING, FIGURE 1

TOP VIEW

NOTES:

1. RECOMMENDED FLOOR ANCHOR: 1/2" ITW RAMSET/RED HEAD SELF DRILLING ANCHOR, ICBO #ER-1372 OR EQUIVALENT (NOT SUPPLIED). FOLLOW MANUFACTURER'S INSTRUCTIONS.
2. POSITION REAR FLOOR BRACKETS ON FLOOR AT LEAST .75" FROM BACK WALL. MARK LOCATION AND DRILL HOLES (FIG. 1) TO A MINIMUM DEPTH OF 4.12" INTO THE CONCRETE.
3. INSTALL REAR CABINET BASE BRACKET (FIG. 2) TO EXISTING HOLES ON UNDERSIDE OF UNIT WITH TABS FACING BACK WALL. USE SUPPLIED HARDWARE AND TORQUE TO 365 LB-INCH (41.2 Nm). NOTE, LOOSEN LEVELING BOLT LOCKING NUT AND TIGHTEN AFTER BRACKET IS SECURED.
4. INSTALL FRONT CABINET BASE BRACKET (FIG. 3) TO EXISTING HOLES ON UNDERSIDE OF UNIT WITH BENT FLANGE FACING FRONT. USE SUPPLIED HARDWARE AND TORQUE TO 365 LB-INCH (41.2 Nm). NOTE, LOOSEN LEVELING BOLT LOCKING NUT AND TIGHTEN AFTER BRACKET IS SECURED.
5. MOVE CABINET INTO POSITION WITH REAR TABS INTO SLOTS OF FLOOR BRACKET. TABS TO EXTEND AT LEAST 1/2" THROUGH FLOOR BRACKET (FIG. 2). THEN ATTACH FRONT FLOOR BRACKETS TO FRONT CABINET BASE BRACKET BUT DO NOT FULLY TIGHTEN HARDWARE.
6. MARK HOLE LOCATIONS AND REMOVE BRACKETS. DRILL AND INSTALL FLOOR BRACKETS. UNIT DOOR CAN BE REMOVED FOR BETTER ACCESS. REINSTALL FRONT FLOOR BRACKETS TO FRONT CABINET BRACKETS WITH SUPPLIED HARDWARE AND TORQUE TO 235 LB-IN (26.5 Nm), (FIG. 3).
7. IF SIDE WALLS ARE PRESENT, 5.0 INCH MINIMUM DISTANCE FROM EITHER SIDE WALL IS REQUIRED.
8. REAR AND FRONT FLOOR BRACKETS, AND REAR AND FRONT CABINET BASE BRACKETS ARE 1010 STEEL AND APPROX. .25 INCH THICK.

PS211105
Rev. 0

Figure 12 Seismic anchor drawing: 400 – 600 amp STS2

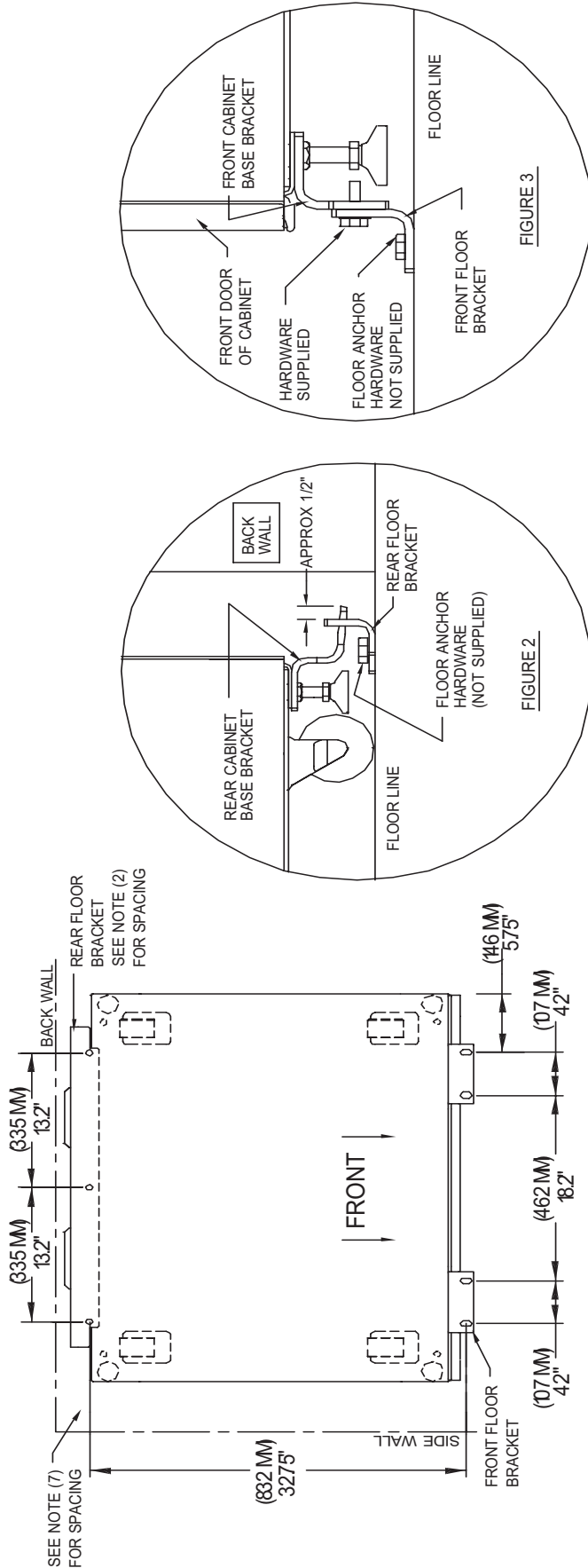

TOP VIEW
SYSTEM SEISMIC ANCHORING, FIGURE 1

NOTES:

1. RECOMMENDED FLOOR ANCHOR: 1/2" ITW RAMSET/TIRE HEAD SELF DRILLING ANCHOR, ICBO #ER-1372 OR EQUIVALENT (NOT SUPPLIED). FOLLOW MANUFACTURER'S INSTRUCTIONS.
2. POSITION REAR FLOOR BRACKETS ON FLOOR AT LEAST .75" FROM BACK WALL. MARK LOCATION AND DRILL HOLES (FIG. 1) TO A MINIMUM DEPTH OF 4.12" INTO THE CONCRETE.
3. INSTALL REAR CABINET BASE BRACKET (FIG. 2) TO EXISTING HOLES ON UNDERSIDE OF UNIT WITH TABS FACING BACK WALL. USE SUPPLIED HARDWARE AND TORQUE TO 365 LB-INCH (41.2 Nm). NOTE, LOOSEN LEVELING BOLT LOCKING NUT AND TIGHTEN AFTER BRACKET IS SECURED.
4. INSTALL FRONT CABINET BASE BRACKET (FIG. 3) TO EXISTING HOLES ON UNDERSIDE OF UNIT WITH BENT FLANGE FACING FRONT. USE SUPPLIED HARDWARE AND TORQUE TO 365 LB-INCH (41.2 Nm). NOTE, LOOSEN LEVELING BOLT LOCKING NUT AND TIGHTEN AFTER BRACKET IS SECURED.
5. MOVE CABINET INTO POSITION WITH REAR TABS INTO SLOTS OF FLOOR BRACKET. TABS TO EXTEND AT LEAST 1/2" THROUGH FLOOR BRACKET (FIG. 2). THEN ATTACH FRONT FLOOR BRACKETS TO FRONT CABINET BASE BRACKET BUT DO NOT FULLY TIGHTEN HARDWARE.
6. MARK HOLE LOCATIONS AND REMOVE BRACKETS. DRILL AND INSTALL FLOOR BRACKETS. UNIT DOOR CAN BE REMOVED FOR BETTER ACCESS. REINSTALL FRONT FLOOR BRACKETS TO FRONT CABINET BRACKETS WITH SUPPLIED HARDWARE AND TORQUE TO 235 LB-IN (26.5 Nm), (FIG. 3).
7. IF SIDE WALLS ARE PRESENT, 5.0 INCH MINIMUM DISTANCE FROM EITHER SIDE WALL IS REQUIRED.
8. REAR AND FRONT FLOOR BRACKETS, AND REAR AND FRONT CABINET BASE BRACKETS ARE 1010 STEEL AND APPROX. .25 INCH THICK.

PS211405
Rev. 0

Figure 13 Seismic anchor drawing: 800 – 1000 amp STS2

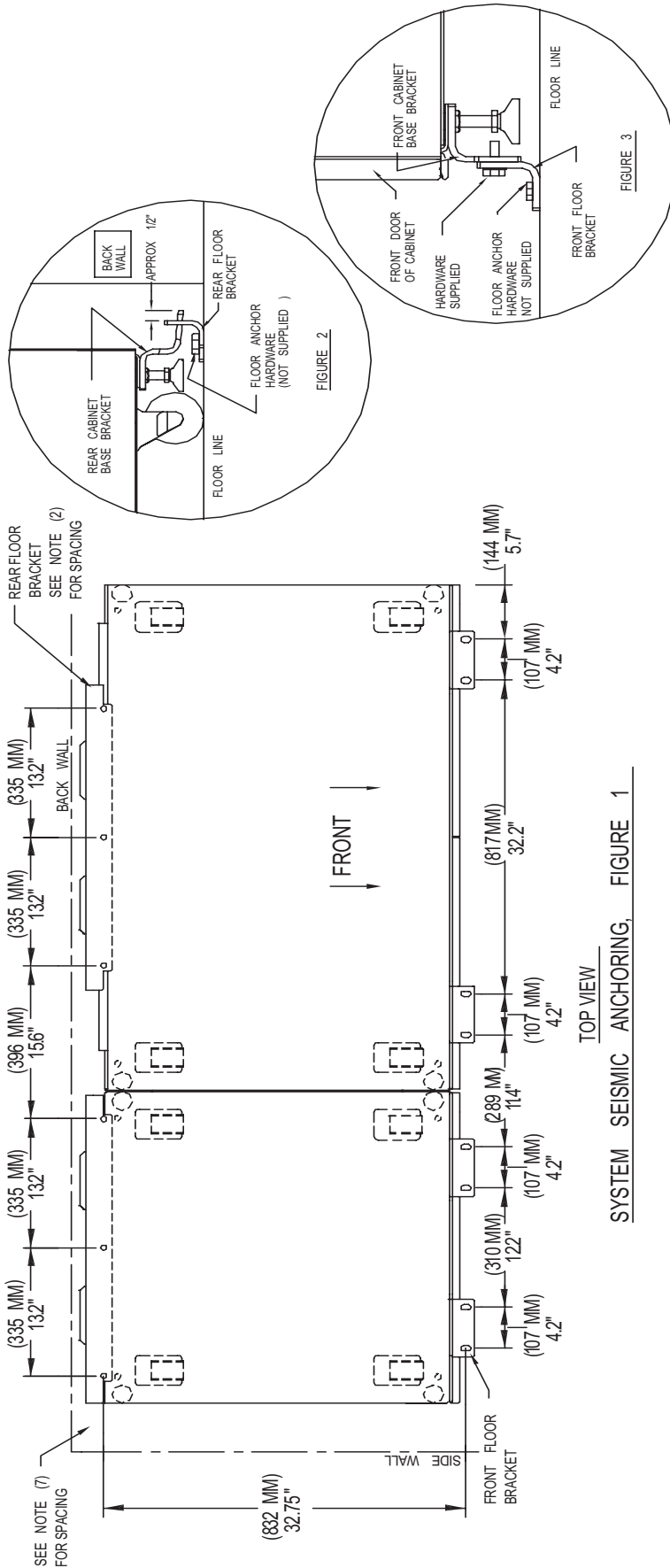

SYSTEM SEISMIC ANCHORING, FIGURE 1

NOTES:

1. RECOMMENDED FLOOR ANCHOR: 1/2" ITW RAMSET/RED HEAD SELF DRILLING ANCHOR, ICBO #ER-1372 OR EQUIVALENT (NOT SUPPLIED). FOLLOW MANUFACTURER'S INSTRUCTIONS.
2. POSITION REAR FLOOR BRACKETS ON FLOOR AT LEAST .75" FROM BACK WALL. MARK LOCATION AND DRILL HOLES (FIG. 1) TO A MINIMUM DEPTH OF 4.12" INTO THE CONCRETE.
3. INSTALL REAR CABINET BASE BRACKET (FIG. 2) TO EXISTING HOLES ON UNDERSIDE OF UNIT WITH TABS FACING BACK WALL. USE SUPPLIED HARDWARE AND TORQUE TO 365 LB-INCH (41.2 Nm). NOTE, LOOSEN LEVELING BOLT LOCKING NUT AND TIGHTEN AFTER BRACKET IS SECURED.
4. INSTALL FRONT CABINET BASE BRACKET (FIG. 3) TO EXISTING HOLES ON UNDERSIDE OF UNIT WITH BENT FLANGE FACING FRONT. USE SUPPLIED HARDWARE AND TORQUE TO 365 LB-INCH (41.2 Nm). NOTE, LOOSEN LEVELING BOLT LOCKING NUT AND TIGHTEN AFTER BRACKET IS SECURED.
5. MOVE CABINET INTO POSITION WITH REAR TABS INTO SLOTS OF FLOOR BRACKET. TABS TO EXTEND AT LEAST 1/2" THROUGH FLOOR BRACKET (FIG. 2). THEN ATTACH FRONT FLOOR BRACKETS TO FRONT CABINET BASE BRACKET BUT DO NOT FULLY TIGHTEN HARDWARE.
6. MARK HOLE LOCATIONS AND REMOVE BRACKETS. DRILL AND INSTALL FLOOR BRACKETS. UNIT DOOR CAN BE REMOVED FOR BETTER ACCESS. REINSTALL FRONT FLOOR BRACKETS TO FRONT CABINET BRACKETS WITH SUPPLIED HARDWARE AND TORQUE TO 235 LB-IN (26.5 Nm), (FIG. 3).
7. IF SIDE WALLS ARE PRESENT, 5.0 INCH MINIMUM DISTANCE FROM EITHER SIDE WALL IS REQUIRED.
8. REAR AND FRONT FLOOR BRACKETS, AND REAR AND FRONT CABINET BASE BRACKETS ARE 1010 STEEL AND APPROX. .25 INCH THICK.

PS211805
Rev. 0

Figure 14 Electrical field connections drawing: 100 – 250 amp STS2 with single output breaker

NOTES:

1. ALL DIMENSIONS ARE IN INCHES AND (MILLIMETERS).
2. TOP AND BOTTOM CABLE ENTRY AVAILABLE THROUGH REMOVABLE ACCESS PLATES. REMOVE, PUNCH TO SUIT CONDUIT SIZE, AND REPLACE.
3. CONTROL WIRING AND POWER WIRING MUST BE RUN IN SEPARATE CONDUIT. OUTPUT CABLES SHOULD BE RUN IN A SEPARATE CONDUIT FROM INPUT CABLES.
4. ALUMINUM AND COPPER CLAD ALUMINUM CABLES ARE NOT RECOMMENDED.
5. ALL WIRING IS TO BE IN ACCORDANCE WITH NATIONAL AND LOCAL ELECTRICAL CODES.
6. HARDWARE KIT IS SUPPLIED FOR INPUT, OUTPUT, NEUTRAL, AND GROUND CABLE CONNECTIONS. KIT INCLUDES 1/2" BOLTS, WASHERS, AND NUTS FOR CONNECTING CABLES TO THE BUS BARS.
7. THE TORQUE REQUIREMENT FOR 1/2"-13 PEM NUTS IS 428 INCH-LBS. (48 N-m).

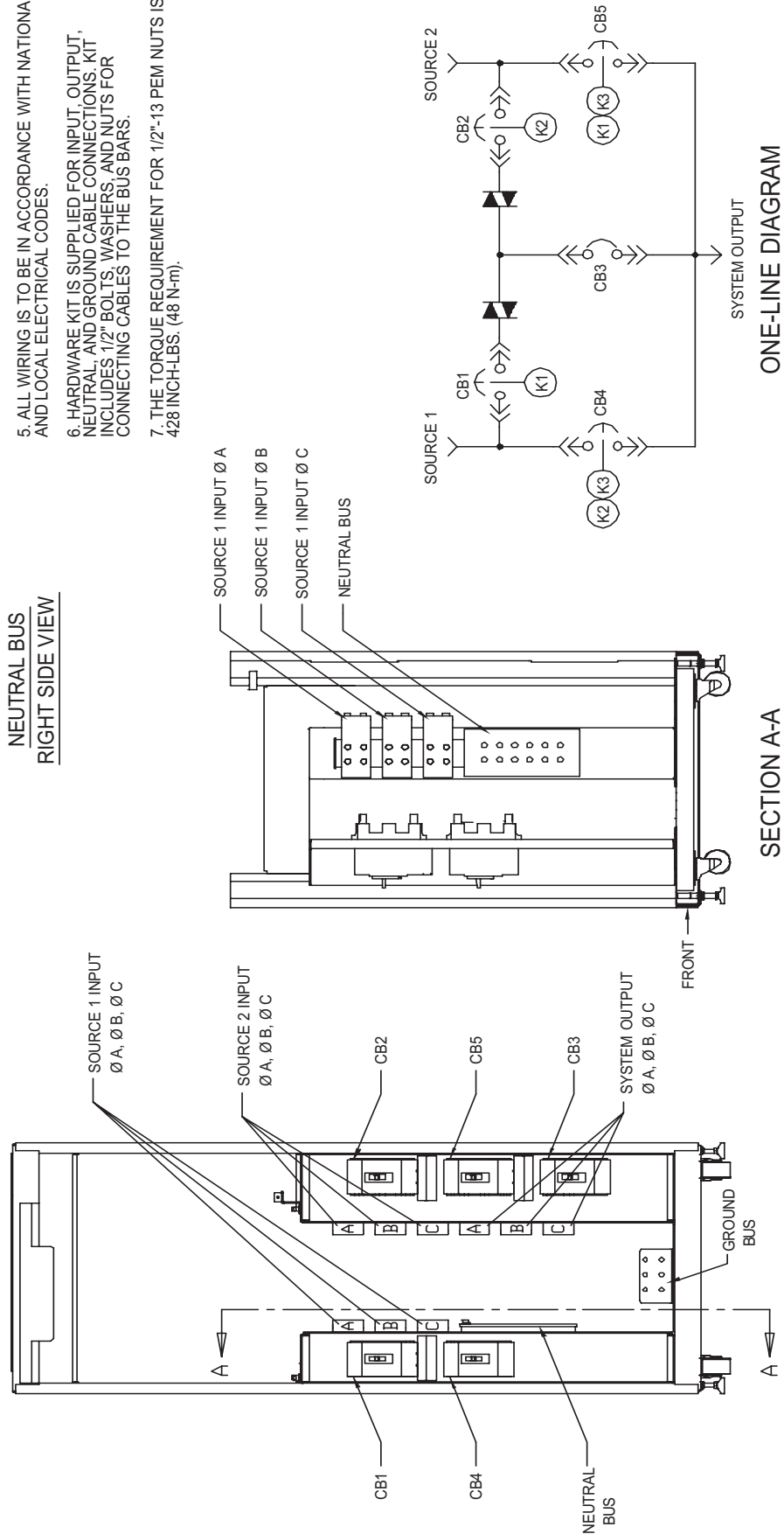
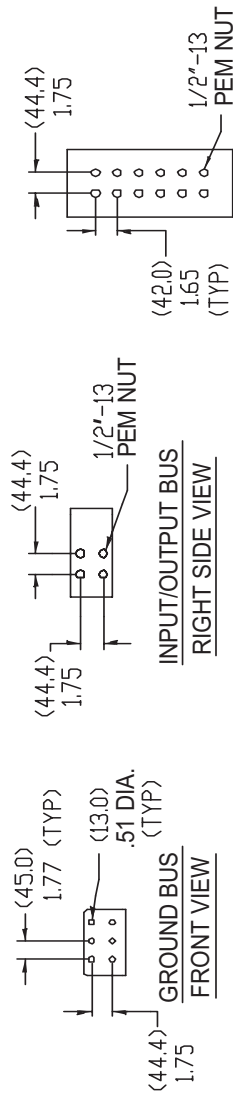

PS212100
 Rev. 3

Figure 15 Electrical field connections drawing: 100 – 250 amp STS2 with dual output breakers

NOTES:

1. ALL DIMENSIONS ARE IN INCHES AND (MILLIMETERS).
2. TOP AND BOTTOM CABLE ENTRY AVAILABLE THROUGH REMOVABLE ACCESS PLATES. REMOVE, PUNCH TO SUIT CONDUIT SIZE, AND REPLACE.
3. CONTROL WIRING AND POWER WIRING MUST BE RUN IN SEPARATE CONDUIT. OUTPUT CABLES SHOULD BE RUN IN A SEPARATE CONDUIT FROM INPUT CABLES.
4. ALUMINUM AND COPPER CLAD ALUMINUM CABLES ARE NOT RECOMMENDED.
5. ALL WIRING IS TO BE IN ACCORDANCE WITH NATIONAL AND LOCAL ELECTRICAL CODES.
6. HARDWARE KIT IS SUPPLIED FOR INPUT, OUTPUT, NEUTRAL, AND GROUND CABLE CONNECTIONS. KIT INCLUDES 1/2" BOLTS, WASHERS, AND NUTS FOR CONNECTING CABLES TO THE BUS BARS.
7. THE TORQUE REQUIREMENT FOR 1/2"-13 PEM NUTS IS 428 INCH-LBS. (48 N-m).

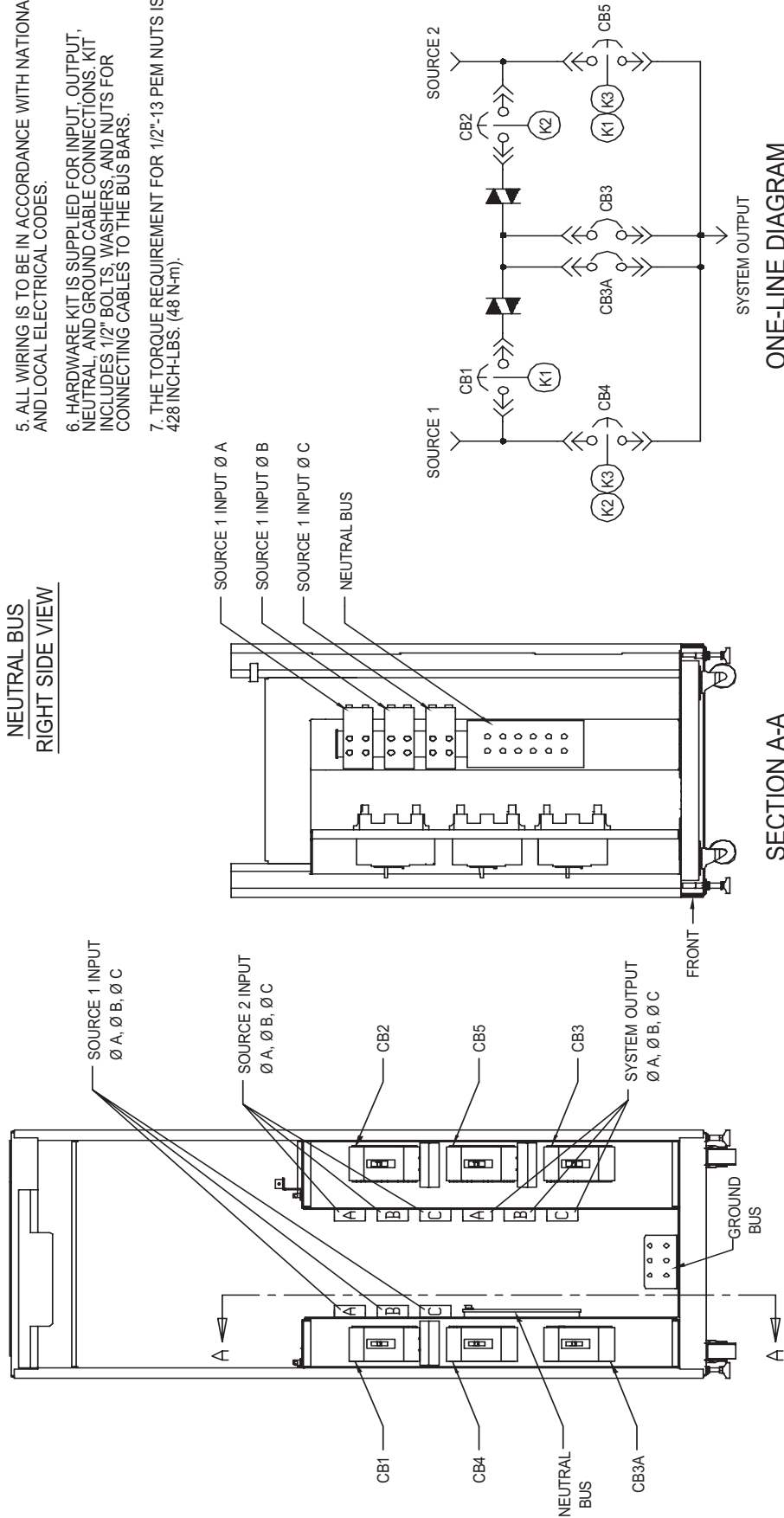
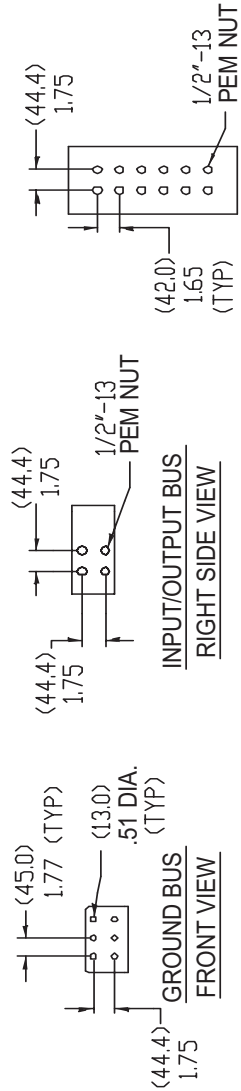

PS212101
 Rev. 3

Figure 16 Electrical field connections drawing: 400 – 600 amp STS2 with single output breaker

NOTES:

1. ALL DIMENSIONS ARE IN INCHES AND (MILLIMETERS).
2. TOP AND BOTTOM CABLE ENTRY AVAILABLE THROUGH REMOVABLE ACCESS PLATES. REMOVE, PUNCH TO SUIT CONDUIT SIZE, AND REPLACE.
3. CONTROL WIRING AND POWER WIRING MUST BE RUN IN SEPARATE CONDUIT. OUTPUT CABLES SHOULD BE RUN IN A SEPARATE CONDUIT FROM INPUT CABLES.
4. ALUMINUM AND COPPER CLAD ALUMINUM CABLES ARE NOT RECOMMENDED.
5. ALL WIRING IS TO BE IN ACCORDANCE WITH NATIONAL AND LOCAL ELECTRICAL CODES.
6. HARDWARE KIT IS SUPPLIED FOR INPUT, OUTPUT, NEUTRAL, AND GROUND CABLE CONNECTIONS. KIT INCLUDES 1/2" BOLTS, WASHERS, AND NUTS FOR CONNECTING CABLES TO THE BUS BARS.
7. THE TORQUE REQUIREMENT FOR 1/2"-13 PEM NUTS IS 428 INCH-LBS. (48 N-m).

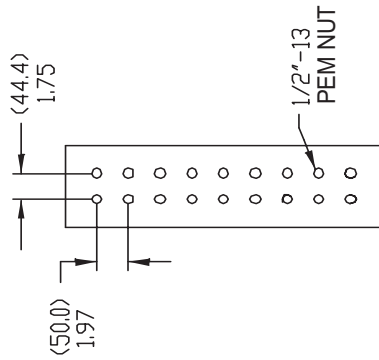

NEUTRAL BUS
RIGHT SIDE VIEW

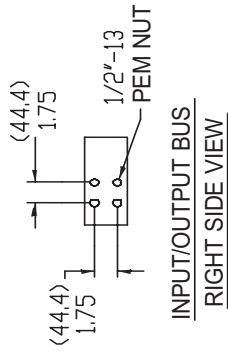

INPUT/OUTPUT BUS
RIGHT SIDE VIEW

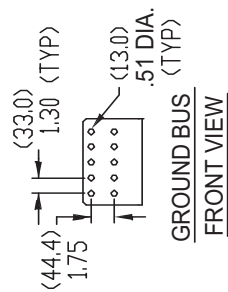

GROUND BUS
FRONT VIEW

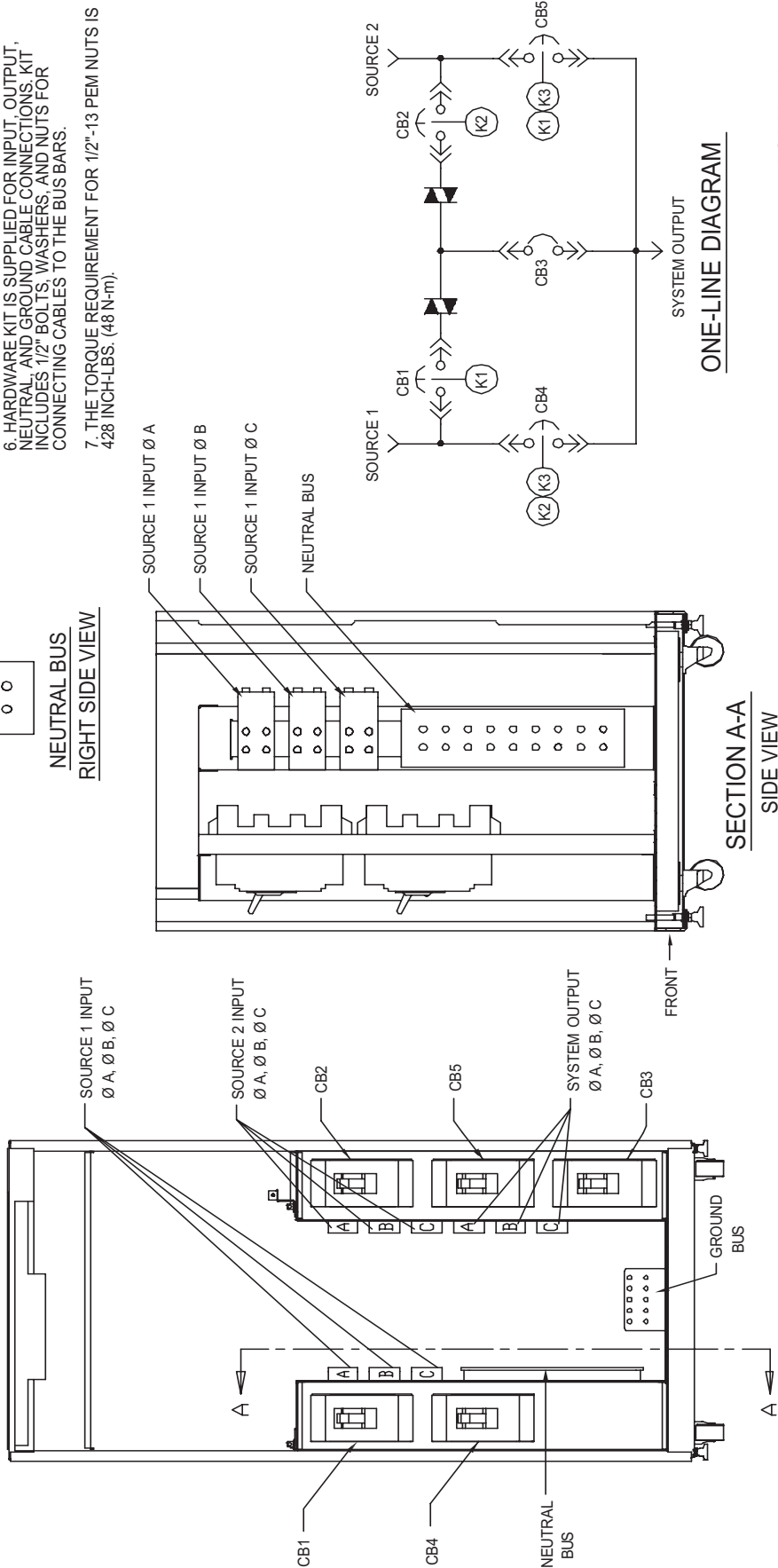

PS212400
Rev. 2

Figure 17 Electrical field connections drawing: 400 – 600 amp STS2 with dual output breakers

NOTES:

1. ALL DIMENSIONS ARE IN INCHES AND (MILLIMETERS).
2. TOP AND BOTTOM CABLE ENTRY AVAILABLE THROUGH REMOVABLE ACCESS PLATES. REMOVE, PUNCH TO SUIT CONDUIT SIZE, AND REPLACE.
3. CONTROL WIRING AND POWER WIRING MUST BE RUN IN SEPARATE CONDUIT. OUTPUT CABLES SHOULD BE RUN IN A SEPARATE CONDUIT FROM INPUT CABLES.
4. ALUMINUM AND COPPER CLAD ALUMINUM CABLES ARE NOT RECOMMENDED.
5. ALL WIRING IS TO BE IN ACCORDANCE WITH NATIONAL AND LOCAL ELECTRICAL CODES.
6. HARDWARE KIT IS SUPPLIED FOR INPUT, OUTPUT, NEUTRAL, AND GROUND CABLE CONNECTIONS. KIT INCLUDES 1/2" BOLTS, WASHERS, AND NUTS FOR CONNECTING CABLES TO THE BUS BARS.
7. THE TORQUE REQUIREMENT FOR 1/2"-13 PEM NUTS IS 428 INCH-LBS. (48 N·m).

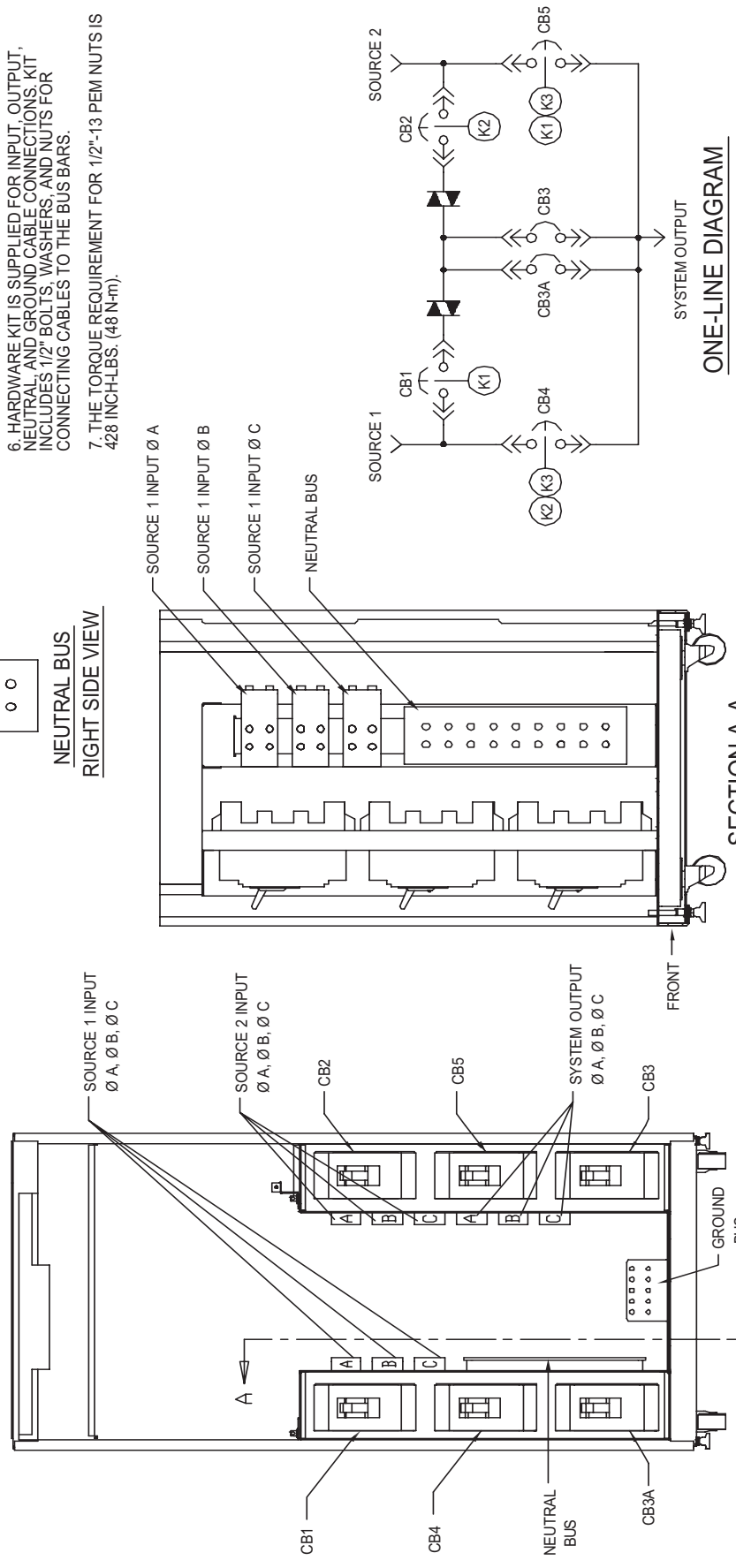
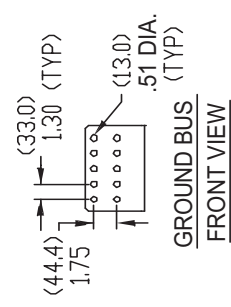
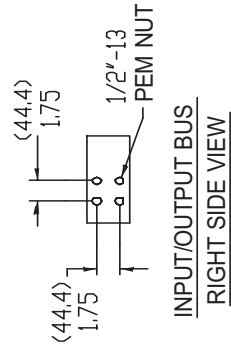
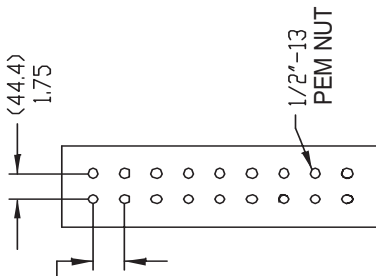

PS212401
Rev. 2

Figure 18 Electrical field connections drawing: 800 – 1000 amp STS2 with single output breaker

NOTES:

1. ALL DIMENSIONS ARE IN INCHES AND (MILLIMETERS).
2. TOP AND BOTTOM CABLE ENTRY AVAILABLE THROUGH REMOVABLE ACCESS PLATES. REMOVE, PUNCH TO SUIT CONDUIT SIZE, AND REPLACE.
3. CONTROL WIRING AND POWER WIRING MUST BE RUN IN SEPARATE CONDUIT. OUTPUT CABLES SHOULD BE RUN IN A SEPARATE CONDUIT FROM INPUT CABLES.
4. ALUMINUM AND COPPER CLAD ALUMINUM CABLES ARE NOT RECOMMENDED.
5. ALL WIRING IS TO BE IN ACCORDANCE WITH NATIONAL AND LOCAL ELECTRICAL CODES.
6. HARDWARE KIT IS SUPPLIED FOR INPUT, OUTPUT, NEUTRAL, AND GROUND CABLE CONNECTIONS. KIT INCLUDES 1/2" BOLTS, WASHERS, AND NUTS FOR CONNECTING CABLES TO THE BUS BARS.
7. THE TORQUE REQUIREMENT FOR 1/2"-13 PEM NUTS IS 428 INCH-LBS. (48 N-m).

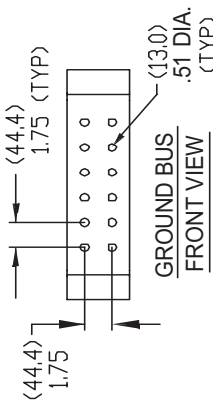
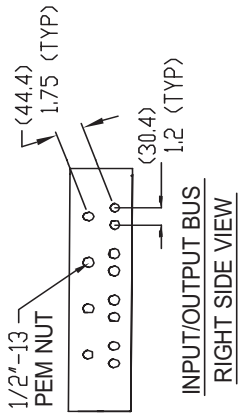
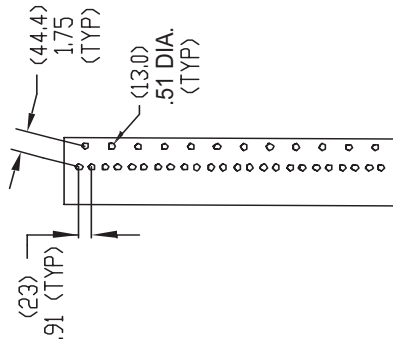

NEUTRAL BUS
RIGHT SIDE VIEW

INPUT/OUTPUT BUS
RIGHT SIDE VIEW

GROUND BUS
FRONT VIEW

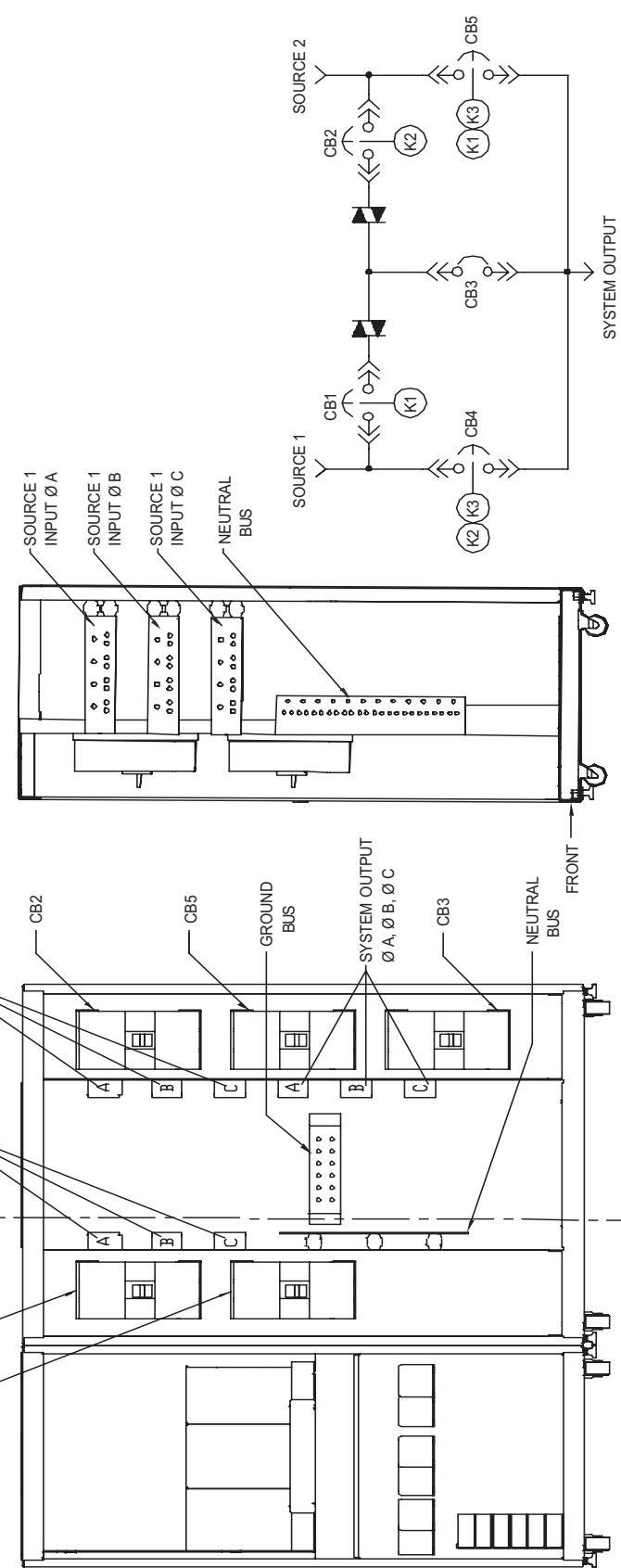

ONE-LINE DIAGRAM

SECTION A-A
SIDE VIEW

FRONT VIEW
(WITH FRONT PANELS REMOVED)

PS212800
Rev. 2

Figure 19 Electrical field connections: 800 – 1000 amp STS2 with dual output breakers

NOTES:

1. ALL DIMENSIONS ARE IN INCHES AND (MILLIMETERS).
2. TOP AND BOTTOM CABLE ENTRY AVAILABLE THROUGH REMOVABLE ACCESS PLATES. REMOVE, PUNCH TO SUIT CONDUIT SIZE, AND REPLACE.
3. CONTROL WIRING AND POWER WIRING MUST BE RUN IN SEPARATE CONDUIT. OUTPUT CABLES SHOULD BE RUN IN A SEPARATE CONDUIT FROM INPUT CABLES.
4. ALUMINUM AND COPPER CLAD ALUMINUM CABLES ARE NOT RECOMMENDED.
5. ALL WIRING IS TO BE IN ACCORDANCE WITH NATIONAL AND LOCAL ELECTRICAL CODES.
6. HARDWARE KIT IS SUPPLIED FOR INPUT, OUTPUT, NEUTRAL AND GROUND CABLE CONNECTIONS. KIT INCLUDES 1/2" BOLTS, WASHERS, AND NUTS FOR CONNECTING CABLES TO THE BUS BARS.
7. THE TORQUE REQUIREMENT FOR 1/2"-13 PEM NUTS IS 428 INCH-LBS. (48 N-m).

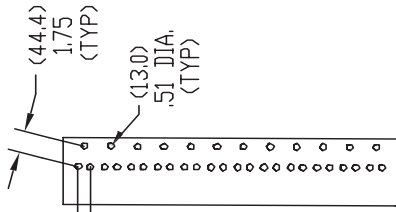

NEUTRAL BUS
RIGHT SIDE VIEW

SOURCE 1 INPUT
φ A, φ B, φ C

SOURCE 2 INPUT
φ A, φ B, φ C

GROUND BUS

SYSTEM OUTPUT
φ A, φ B, φ C

NEUTRAL BUS

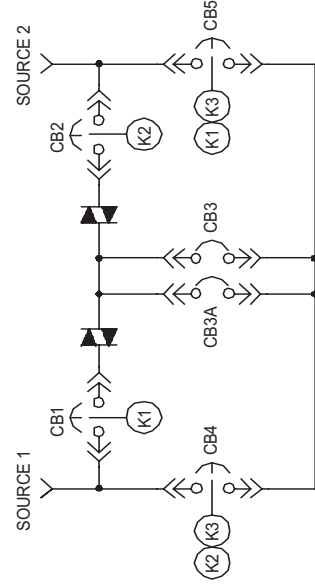
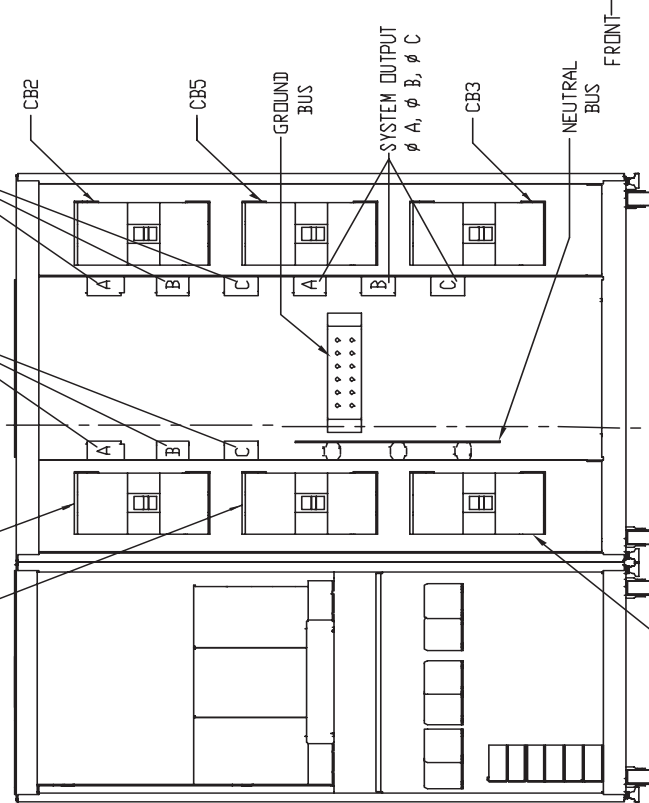
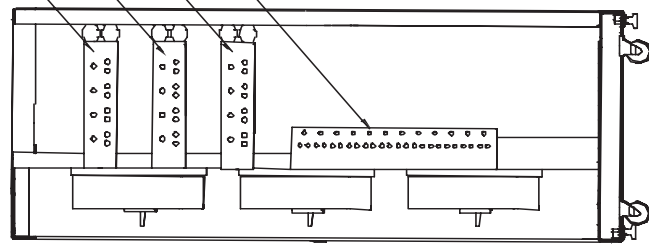

PS212801
Rev. 2

Figure 20 Circuit breaker schedule

STATIC TRANSFER SWITCH 2, MOLDED CASE BREAKER SCHEDULE						
STS2 RATING	VENDOR	TYPE	AMPACITY	VOLTAGE	WITHSTAND CURRENT	
100A	MERLIN GERIN	NSF	150A	200-240V 380-480V 600V	100K 65K 25K	
250A	MERLIN GERIN	NSF	250A	200-240V 380-480V 600V	100K 65K 25K	
400A	MERLIN GERIN	NSJ	400A	200-240V 380-480V 600V	100K 100K 25K	
600A	MERLIN GERIN	NSJ	600A	200-240V 380-480V 600V	100K 100K 25K	
800A	SQD	PJ	800A	200-240V 380-480V 600V	100K 65K 25K	
1000A	SQD	PJ	1200A	200-240V 380-480V 600V	100K 65K 25K	

NOTES:

1. THE STS2 AUTOMATIC MOLDED CASE BREAKERS ARE 3 POLE, 600VAC RATED WITH MAGNETIC TRIP ONLY.
2. UPSTREAM DEVICES (BY OTHERS) MUST BE USED TO PROVIDE OVERCURRENT PROTECTION. UPSTREAM OVERCURRENT PROTECTION SHOULD HAVE AMPACITY EQUAL TO OR LESS THAN THE AMPERE RATING OF THE STATIC SWITCH MOLDED CASE BREAKER.

CIRCUIT BREAKER SCHEDULE
 100AMP TO 1000AMP
 STATIC TRANSFER SWITCH 2

PS214000 REV. NO. 3

Figure 21 Control connection location diagram: 100 – 600 amp STS2

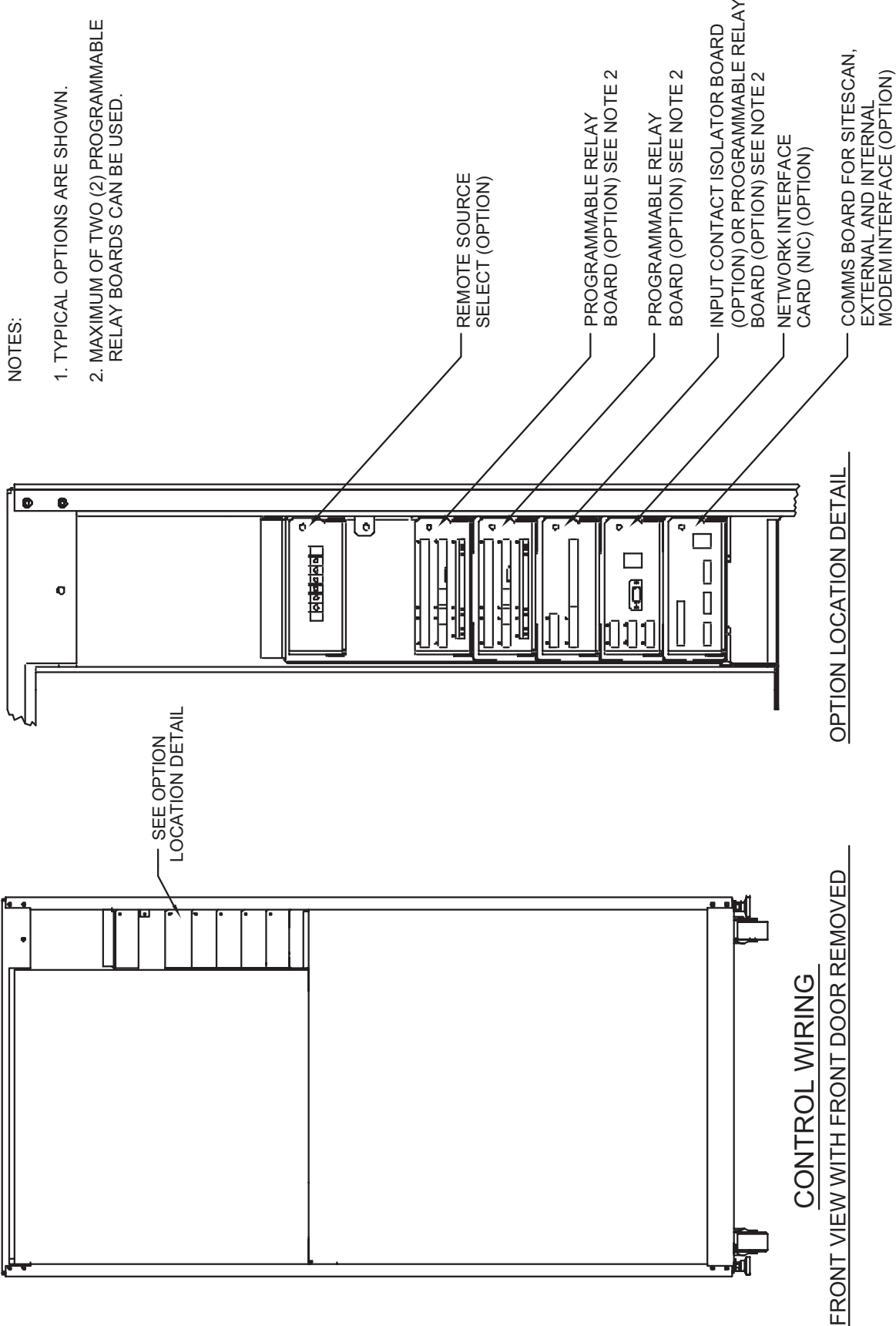

PS213000
Rev. 1

Figure 22 Control connection location diagram: 800 – 1000 amp STS2

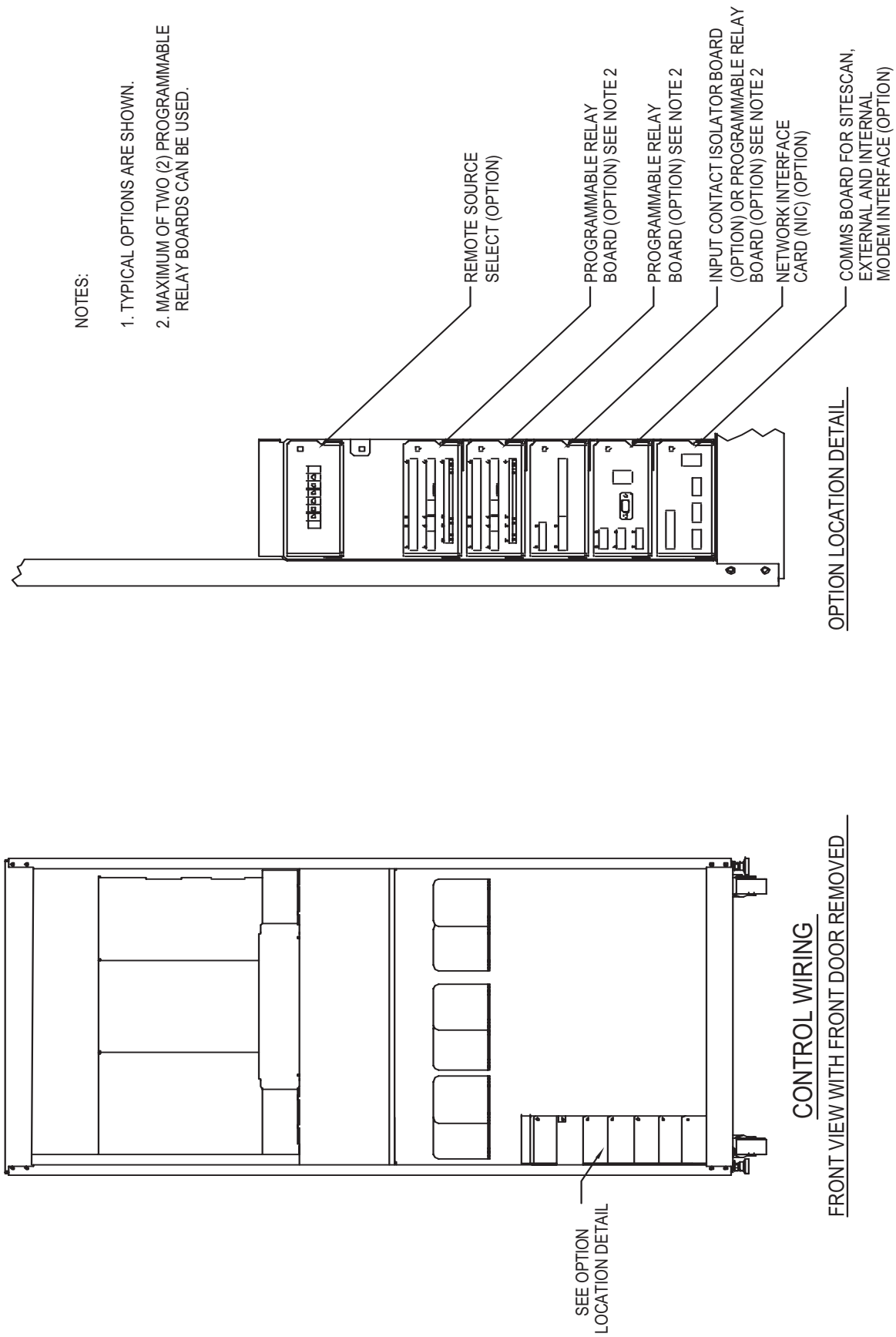

PS213800
Rev. 1

Figure 23 Control wiring for remote source selection option

NOTES:

1. CUSTOMER PROVIDED NORMALLY OPEN DRY CONTACTS. RATING 10mA AT 30VDC.
2. MAXIMUM CABLE LENGTH 500 FT. (152 METERS) WITH #16AWG 300V MINIMUM, FLEXIBLE STRANDED CABLE.
3. ALL CONTROL WIRING (BY OTHERS) MUST BE RUN SEPARATE FROM POWER WIRING. CONTROL WIRING RUNS SHOULD NOT BE COMBINED IN THE SAME CONDUIT.
4. REFER TO STATIC TRANSFER SWITCH CONTROL CONNECTION DIAGRAM FOR LOCATION OF REMOTE SOURCE SELECTION OPT.
5. ALL WIRING MUST BE IN ACCORDANCE WITH NATIONAL AND LOCAL ELECTRICAL CODES.

SEE NOTE 1

SOURCE 1 SOURCE 2
PREFERRED PREFERRED

S1 GND S2 GND

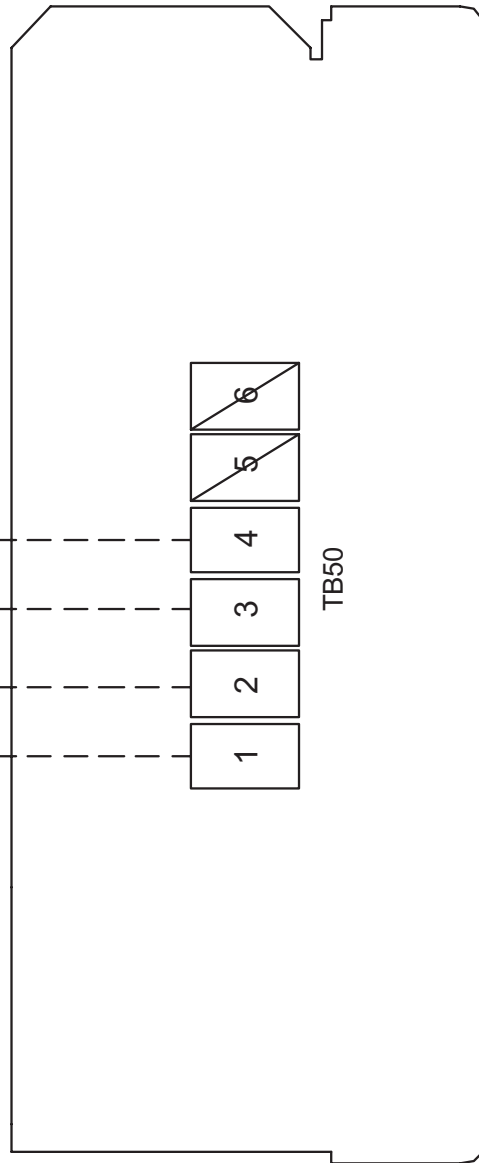

REMOTE SOURCE SELECTION

PS213007
Rev. 1

Figure 24 Control wiring for the programmable relay board option

- NOTES:
1. CUSTOMER CONTROL WIRING CONNECTION POINTS ARE TERMINAL BLOCKS 1 THROUGH 15.
 2. PROGRAMMABLE RELAY BOARD OPTION INCLUDES 8 SIGNAL CHANNELS WITH (2) FORM-C DRY CONTACTS PER CHANNEL. SEE TABLE.
 3. REFER TO INSTALLATION, OPERATION & MAINTENANCE MANUAL FOR CONFIGURING THE PROGRAMMABLE RELAY BOARD OPTION.
 4. ALL CONTROL WIRING (BY OTHERS) MUST BE RUN SEPARATE FROM POWER WIRING. CONTROL WIRING RUNS SHOULD NOT BE COMBINED IN THE SAME CONDUIT.
 5. REFER TO STATIC TRANSFER SWITCH CONTROL CONNECTION DIAGRAM FOR LOCATION OF PROGRAM RELAY BOARD OPTION.
 6. CONTACT RATINGS: 1AMP @ 30VDC, 200mA @125VAC.
 7. MAXIMUM CABLE LENGTH 500 FT. (152 METERS) WITH #16AWG FLEXIBLE STRANDED CABLE.
 8. ALL WIRING MUST BE IN ACCORDANCE WITH NATIONAL AND LOCAL ELECTRICAL CODES.

PS213001
Rev. 2

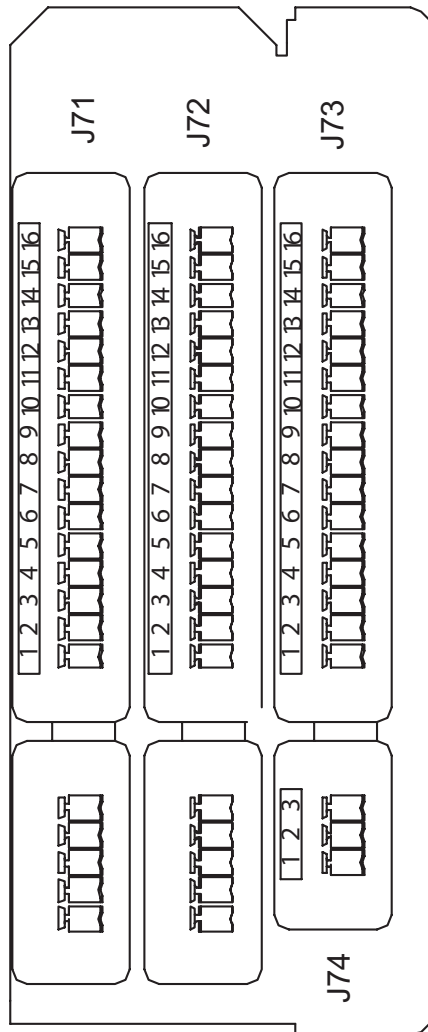

PROGRAMMABLE RELAY BOARD

TABLE

CHANNEL	PIN NO.	C	NC	NO	
J71	CH1	A 1-3	1	2	3
		B 4-6	4	5	6
	CH2	A 7-9	7	8	9
		B 10-12	10	11	12
	CH3	A 13-15	13	14	15
		B 1-3	1	2	3
J72	CH4	A 4-6	4	5	6
		B 7-9	7	8	9
	CH5	A 10-12	10	11	12
		B 13-15	13	14	15
	CH6	A 1-3	1	2	3
		B 4-6	4	5	6
J73	CH7	A 7-9	7	8	9
		B 10-12	10	11	12
J74	CH8	A 13-15	13	14	15
		B 1-3	1	2	3

NOTE: PIN 16 NOT USED ON J71, J72, & J73

Figure 25 Control wiring for the input contact isolator board option

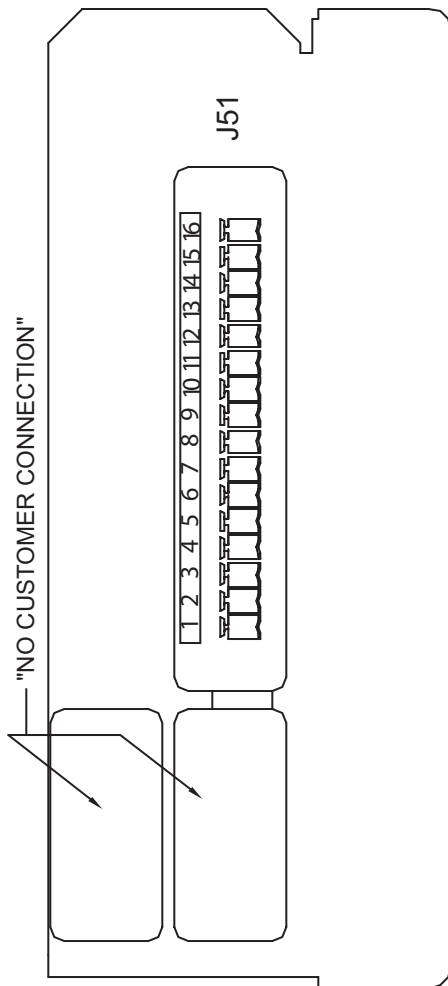

INPUT CONTACT ISOLATOR BOARD

02-810012-XX

TABLE (J51)

INPUT CONTACT	PIN NO.
1	1
2	2
3	3
4	4
5	5
6	6
7	7
8	8
9	9
10	10
11	11
12	12
13	13
14	14
15	15
16	16

NOTES:

1. CUSTOMER CONTROL WIRING CONNECTION POINTS ARE TERMINALS 1 THROUGH 16 (SEE TABLE J51).
2. CUSTOMER PROVIDED NORMALLY OPEN DRY CONTACTS FOR USER ALARM MESSAGES.
3. REFER TO INSTALLATION, OPERATION & MAINTENANCE MANUAL FOR CONFIGURING THE INPUT CONTACT ISOLATOR BOARD OPTION.
4. ALL CONTROL WIRING (BY OTHERS) MUST BE RUN SEPARATE FROM POWER WIRING. CONTROL WIRING RUNS SHOULD NOT BE COMBINED IN THE SAME CONDUIT.
5. REFER TO STATIC TRANSFER SWITCH CONTROL CONNECTION DIAGRAM FOR LOCATION OF INPUT CONTACT ISOLATOR BD. OPT.
6. SIGNAL VOLTAGE: 100mAMP @ 12VDC.
7. MAXIMUM CABLE LENGTH 500 FT. (152 METERS) WITH #16AWG FLEXIBLE STRANDED CABLE.
8. ALL WIRING MUST BE IN ACCORDANCE WITH NATIONAL AND LOCAL ELECTRICAL CODES.

PS213002
Rev. 2

Figure 26 Control wiring for comms board (see Figure 27 on page 39 for internal modem wiring)

NOTES:

1. MAXIMUM CABLE LENGTH 1000 FEET (300 METERS) WITH TWISTED PAIR CABLE #22 AWG 300V MINIMUM.
2. SIGNAL VOLTAGE 5VDC, CURRENT 10mA.
3. REFER TO INSTALLATION, OPERATION & MAINTENANCE MANUAL FOR CONFIGURING THE COMMS BOARD.
4. ALL CONTROL WIRING (BY OTHERS) MUST BE RUN SEPARATE FROM POWER WIRING. CONTROL WIRING RUNS SHOULD NOT BE COMBINED IN THE SAME CONDUIT.
5. REFER TO CONTROL CONNECTION LOCATION DIAGRAM OF STATIC TRANSFER SWITCH FOR LOCATION OF COMMS BOARD.
6. ALL WIRING MUST BE IN ACCORDANCE WITH NATIONAL AND LOCAL ELECTRICAL CODES.

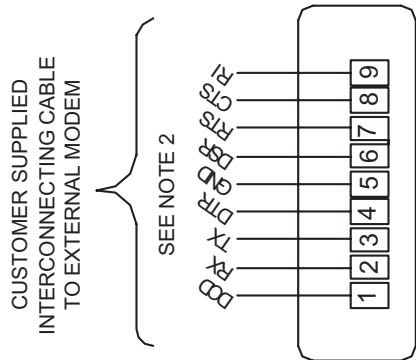

EXTERNAL MODEM
SEE DETAIL A

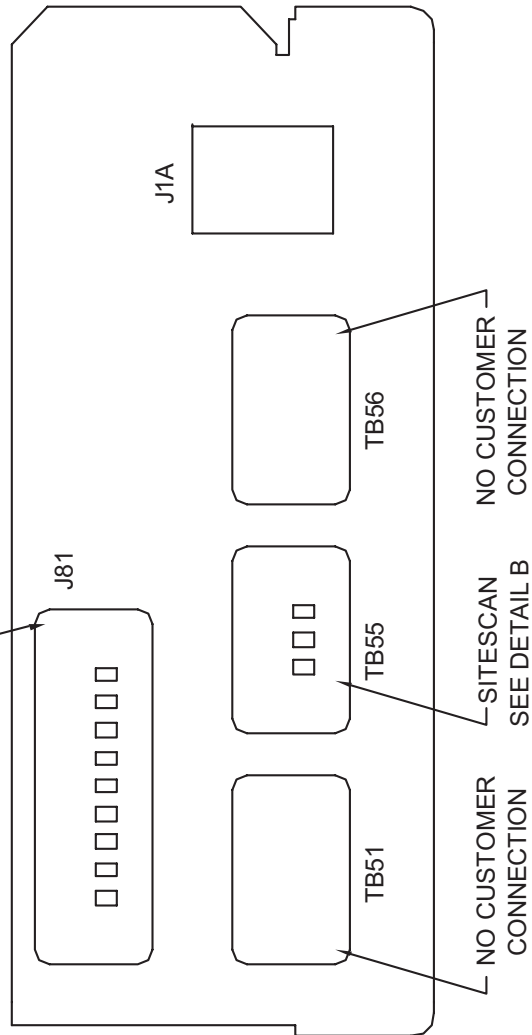

COMMS BOARD
02-810015-XX

CUSTOMER SUPPLIED
INTERCONNECTING
CABLE TO SITESCAN

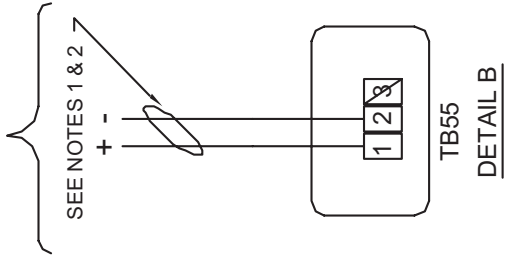

PS213003
Rev. 2

Figure 27 Control wiring for the internal modem option

NOTES:

1. INTERNAL MODEM OPTION MUST BE ORDERED SEPARATELY.
2. WIRE SIZE AND TYPE: TELEPHONE CABLE WITH RJ-11 PLUG CONNECTOR. THE LENGTH IS LIMITED BY INTERNET STANDARDS.
3. REFER TO INSTALLATION, OPERATION & MAINTENANCE MANUAL FOR CONFIGURING THE INTERNAL MODEM OPTION.
4. ALL CONTROL WIRING (BY OTHERS) MUST BE RUN SEPARATE FROM POWER WIRING. CONTROL WIRING RUNS SHOULD NOT BE COMBINED IN THE SAME CONDUIT.
5. REFER TO CONTROL CONNECTION LOCATION DIAGRAM OF STATIC SWITCH FOR LOCATION OF COMMS BOARD.
6. ALL WIRING MUST BE IN ACCORDANCE WITH NATIONAL AND LOCAL ELECTRICAL CODES.

CUSTOMER SUPPLIED
INTERCONNECTING
CABLE (SEE NOTES)

MODEM LINE COMMUNICATIONS
TO TELEPHONE LINE

J1A

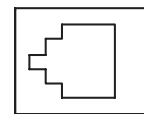

DETAIL A

RJ-11 CONNECTOR

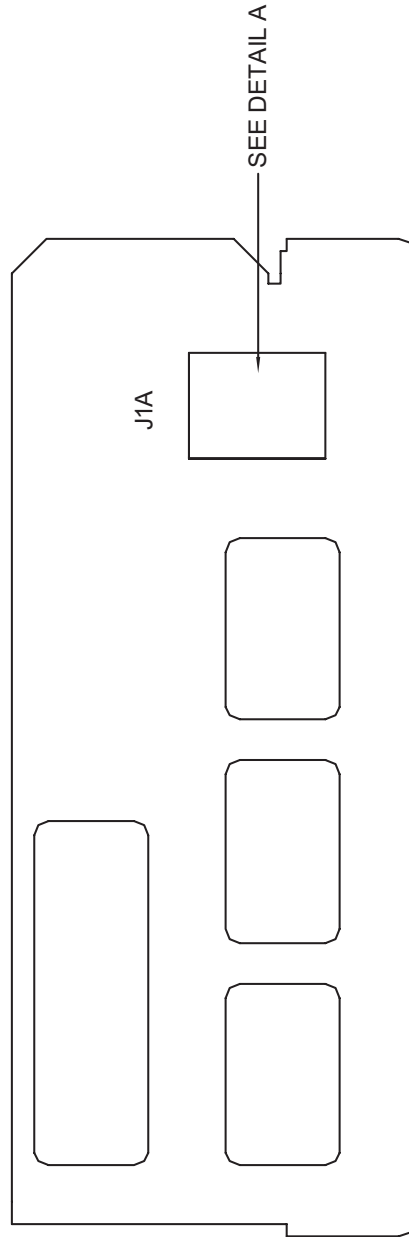

COMMS BOARD

PS213004
Rev. 2

Figure 28 Control wiring for the network interface card (NIC) option

NOTES:

1. WIRE SIZE AND TYPE: 10/100 BASE-T ETHERNET CABLE WITH RJ45 PLUG CONNECTOR. THE LENGTH IS LIMITED BY INTERNET STANDARDS.
2. MAXIMUM CABLE LENGTH 1000 FEET (300 METERS) WITH TWISTED PAIR CABLE #22 AWG MINIMUM. SIGNAL VOLTAGE 5VDC, CURRENT 10mA.
3. REFER TO INSTALLATION, OPERATION & MAINTENANCE MANUAL FOR CONFIGURING THE NETWORK INTERFACE CARD (NIC).
4. ALL CONTROL WIRING (BY OTHERS) MUST BE RUN SEPARATE FROM POWER WIRING. CONTROL WIRING RUNS SHOULD NOT BE COMBINED IN THE SAME CONDUIT.
5. REFER TO CONTROL CONNECTION LOCATION DIAGRAM OF STATIC TRANSFER SWITCH FOR LOCATION OF NETWORK INTERFACE CARD OPTION.
6. ALL WIRING MUST BE IN ACCORDANCE WITH NATIONAL AND LOCAL ELECTRICAL CODES.

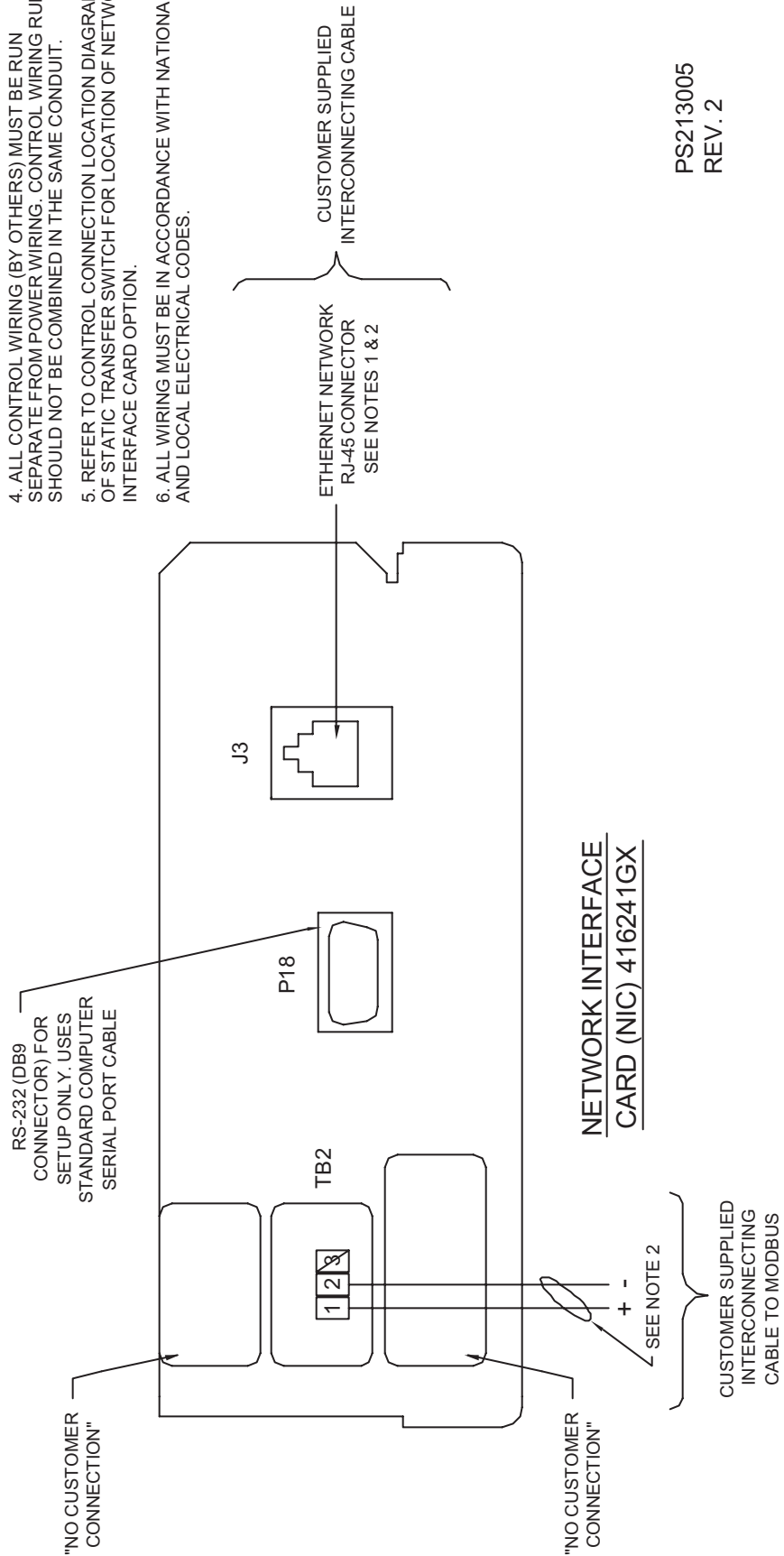

PS213005
REV. 2

Figure 29 Control wiring for the RS-232 port

NOTES:

- 1. RS-232 COMMUNICATION THROUGH DB9 CONNECTOR.
- 2. CONNECTOR ACCESSIBLE WITH FRONT DOOR OPENED. CONNECTOR MUST BE REMOVED PRIOR TO CLOSING DOOR.

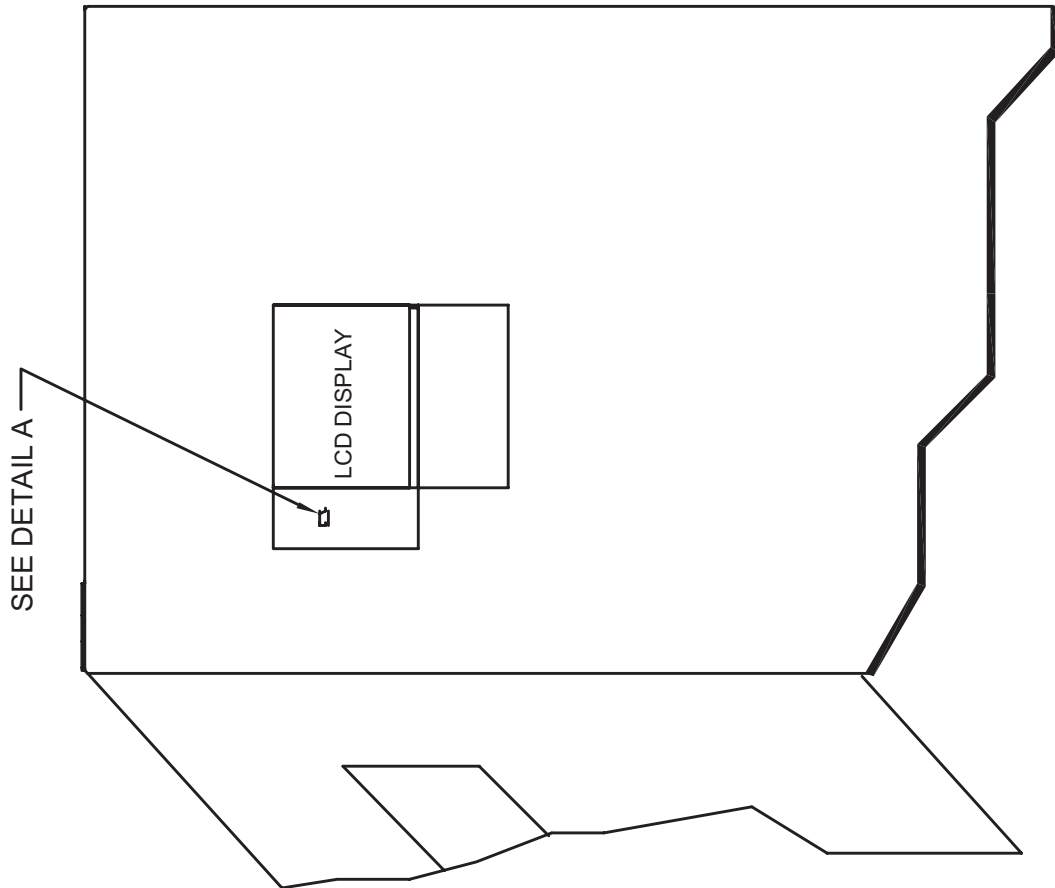
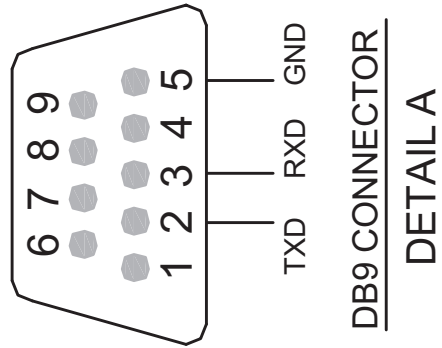

FRONT VIEW
UPPER HALF OF UNIT
WITH DOOR OPENED

PS213006
Rev. 1

Figure 30 Outline drawing for input junction box

- NOTES:
1. TWO JUNCTION BOXES ARE SUPPLIED, ONE FOR EACH INPUT.
 2. CABLE(S) ARE FACTORY SUPPLIED TO CONNECT THE JUNCTION BOX TO THE INPUT BUSBARS. SEE ELECTRICAL FIELD CONNECTIONS DRAWING FOR LOCATION.
 3. PARALLEL CABLES ARE USED ON 400A AND 600A UNITS.

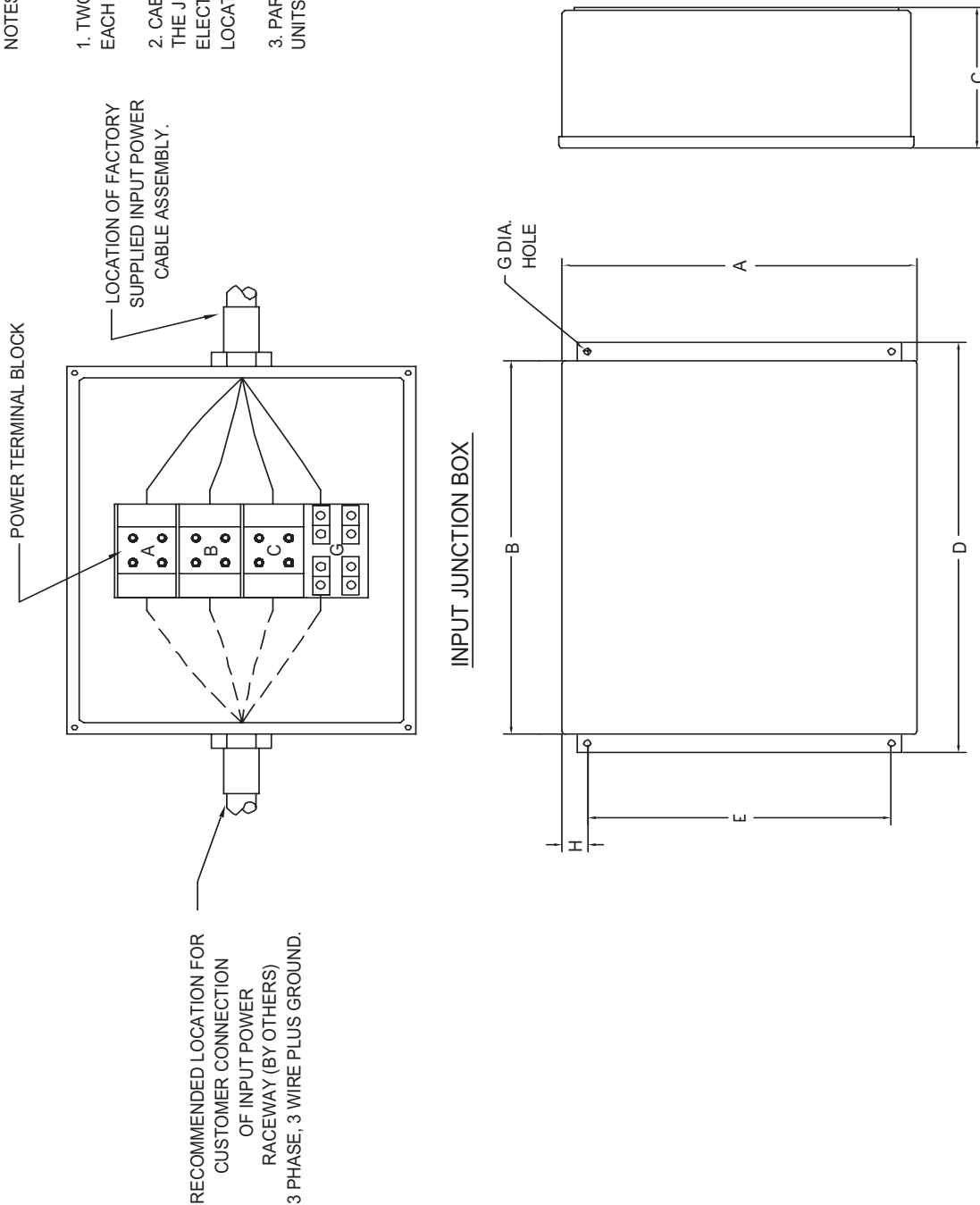

RATING	INPUT JUNCTION BOX								
	DIMENSIONAL DATA - INCHES [mm]								
	A	B	C	D	E	F	G	H	WIRE SIZE RANGE
100A	16 [406]	14 [356]	6 [152]	17 1/2 [445]	12 [305]	16 3/4 [426]	5/16 [8]	1 [25]	#6 AWG TO #2/0 AWG
250A - 600A	16 [406]	30 [762]	6 [152]	33 [830]	10 [254]	32 [813]	7/16 [11]	3 [76]	(2) #6 AWG TO (2) 500 kcmil

PS211005
Rev. 1

Figure 31 Color LCD touch screen display

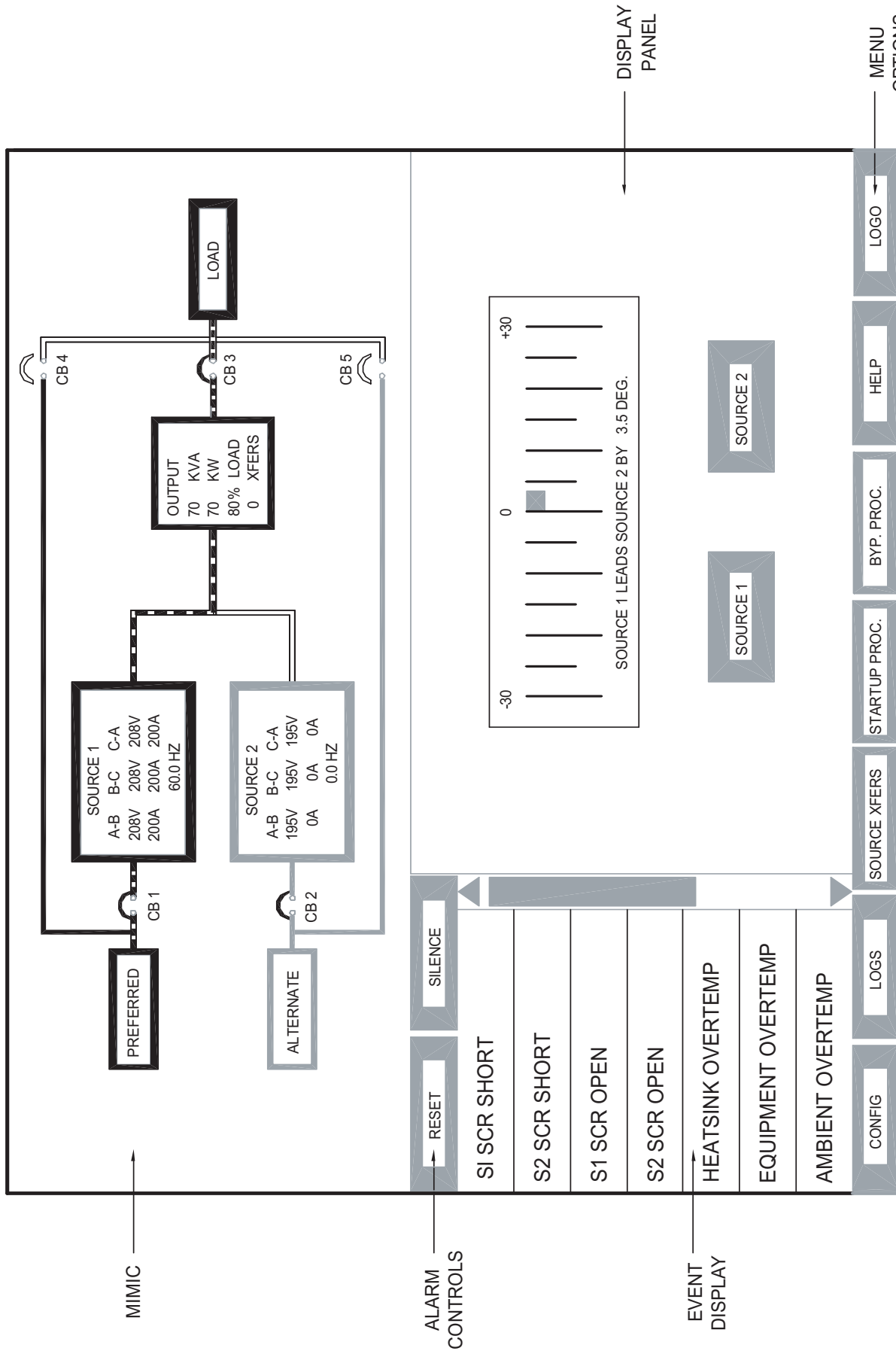
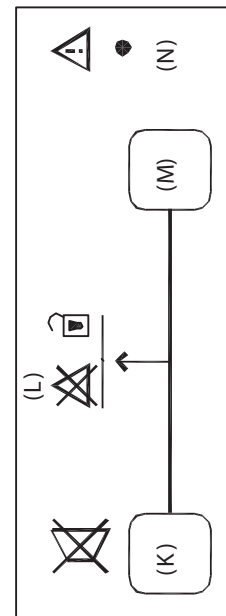
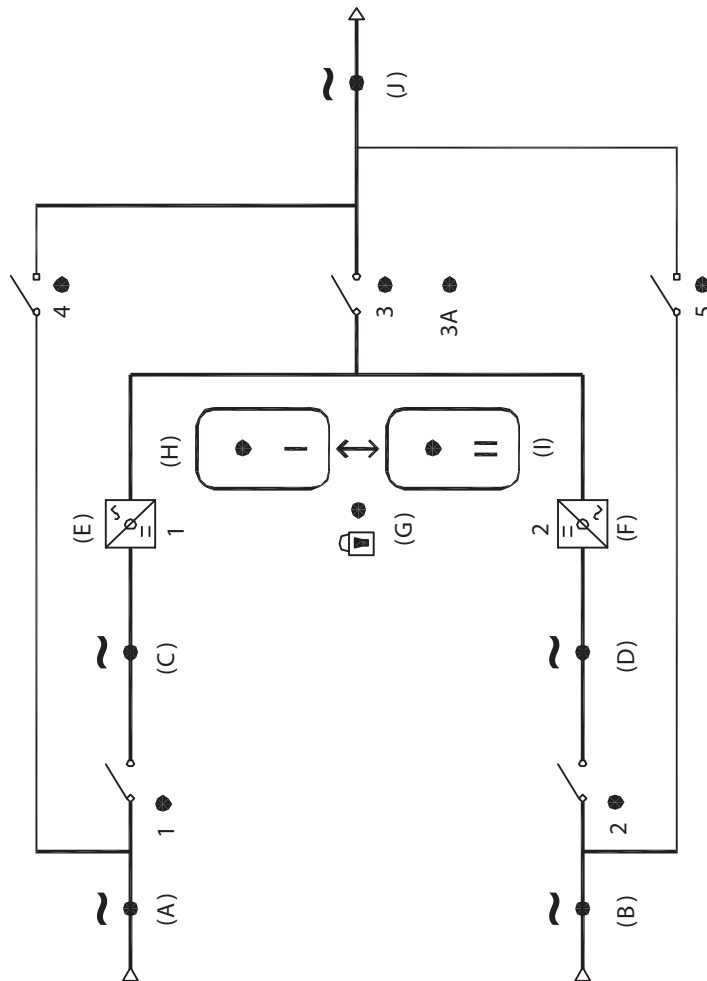

Figure 32 LED display

LED DISPLAY LEGEND

SYMBOL	LED	DESCRIPTION
A	GREEN	SOURCE 1 POWER IS PRESENT
B	GREEN	SOURCE 2 POWER IS PRESENT
C	GREEN	SOURCE 1 WITHIN TOLERANCE
D	GREEN	SOURCE 2 WITHIN TOLERANCE
E	GREEN	SOURCE 1 SCRs ON
F	GREEN	SOURCE 2 SCRs ON
G	YELLOW	SOURCE TRANSFER INHIBITED
H	GREEN	PUSHBUTTON TO SELECT SOURCE 1 AS THE PREFERRED SOURCE
I	GREEN	PUSHBUTTON TO SELECT SOURCE 2 AS THE PREFERRED SOURCE
J	GREEN	OUTPUT POWER IS PRESENT
K		ALARM SILENCE BUTTON
L		SYMBOL TO INDICATE THE K AND M MUST BE PUSHED AT THE SAME TIME TO RESET ALARM
M		ALARM RESET PUSHBUTTON
N	RED	ALARM PRESENT
1	GREEN	CB1 CLOSED
2	GREEN	CB2 CLOSED
3	GREEN	CB3 CLOSED
3A	GREEN	CB3A CLOSED
4	YELLOW	CB4 CLOSED
5	YELLOW	CB5 CLOSED



PS211002
Rev. 0

Figure 33 Installation drawing, seismic floor stand 100-250A

- INSTALLATION NOTES:
1. CHECK ALL HARDWARE FOR PROPER TORQUE PRIOR TO INSTALLATION.
 2. INSTALL REAR LOWER STS2 BRACKET TO THE FLOOR STAND USING EXISTING HOLES WITH BENT FLANGE FACING THE FRONT OF THE FLOOR STAND (FIG. 3 AND FIG 4, DWG PS215001). USE M12-1.75X40mm CAP SCREW, SPLIT LOCK WASHER, AND FLAT WASHER AND TORQUE TO 53 FT-LBS.
 3. LOOSEN THE STS2 ADJUSTABLE LEVELER FEET NUTS (SEE DETAIL C; DWG PS215001). INSTALL REAR UPPER STS2 BRACKET USING EXISTING HOLES ON UNDERSIDE OF THE STS2 WITH TABS FACING OUT (FIG. 1 AND FIG 2, PS215001). INSTALL FRONT UPPER STS2 BRACKET USING EXISTING HOLES ON UNDERSIDE OF THE STS2 WITH BENT FLANGE FACING TO THE FRONT. (FIG.1 AND FIG 2, PS215001). USE M12-1.75X40mm CAP SCREW, SPLIT LOCK WASHER, AND FLAT WASHER AND TORQUE TO 53 FT-LBS. RETIGHTEN LEVELER FEET NUTS.
 4. FLOOR STAND CAN BE MOUNTED NEXT TO A WALL IF NEEDED. REAR ACCESS NOT REQUIRED. INSTALL FLOOR STAND WITH FEET ORIENTATED AS SHOWN IN (BOTTOM VIEW; DWG PS215000). TO ADJUST VERTICAL HEIGHT OF FLOOR STAND FEET. LOOSEN, ADJUST AND TIGHTEN THE NUTS AND JAM NUT SHOWN IN (FOOT DETAIL A & B; ON DWG PS215000). FLOOR STAND MUST BE LEVEL AND ALL FEET MUST BE TOUCHING THE FLOOR. ATTACH FLOOR STAND FEET USING 1/2" X 4" RED HEAD TRUBOLTS EXPANSION ANCHORS (FIELD SUPPLIED) (2) PER FOOT.
 5. ROLL THE STS2 ONTO THE FLOOR STAND SO THAT THE TABS ON THE (REAR UPPER STS2 BRACKET) FIT INTO THE SLOTS ON THE (REAR LOWER STS2 BRACKET). TABS TO EXTEND AT LEAST 1/2" THROUGH FLOOR STAND BRACKET (FIG. 2, DWG PS215002).
 6. INSTALL THE LOWER FRONT BRACKETS (FIG 1, DETAIL A; DWG PS215002). ATTACH BRACKET TO STS2 USING M10-1.50X30mm CAP SCREW, SPLIT LOCK WASHER, AND FLAT WASHER AND TORQUE TO 31 FT-LBS. ATTACH BRACKET TO FLOOR STAND USING M12-1.75X40mm CAP SCREW, SPLIT LOCK WASHER, AND FLAT WASHER AND TORQUE TO 53 FT-LBS

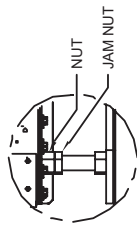

FOOT DETAIL A



FOOT DETAIL B

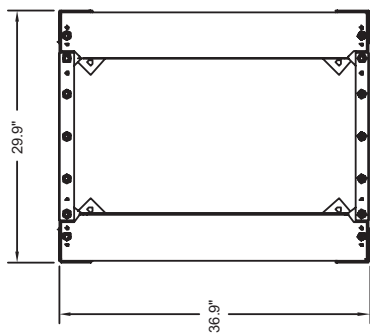

TOP VIEW

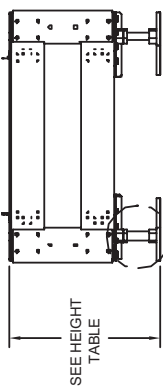

A FRONT VIEW

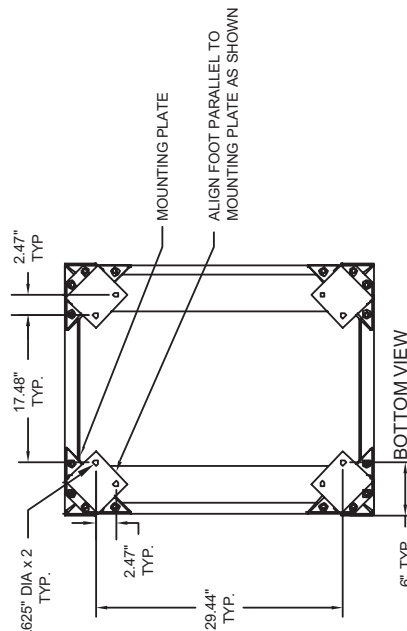

BOTTOM VIEW

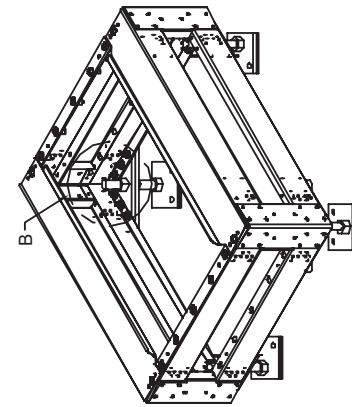

ISOMETRIC VIEW 250A FLOOR STAND

HARDWARE TORQUE CHART	
1.0" NUT	320 FT - LBS
M8 - 1.25	16FT - LBS
M10 - 1.5	31 FT - LBS
M12 - 1.75	53 FT -LBS

HEIGHT TABLE			
P/N OF FLOOR STAND:	HEIGHT	HEIGHT MAX:	HEIGHT MIN:
523401G1	18.0"	19.25"	16.75"
523402G1	24.0"	25.25"	22.75"
523403G1	30.0"	31.25"	28.75"
523404G1	36.0"	37.25"	34.75"

INSTALLATION DRAWING FOR
SEISMIC FLOOR STAND
100-250A STS2

PS215000 REV. NO. 0

Figure 34 Installation drawing, seismic floor stand 100-250A

NOTE:

SEE DWGS PS215000, PS215002, AND PS215003 FOR DETAILS.

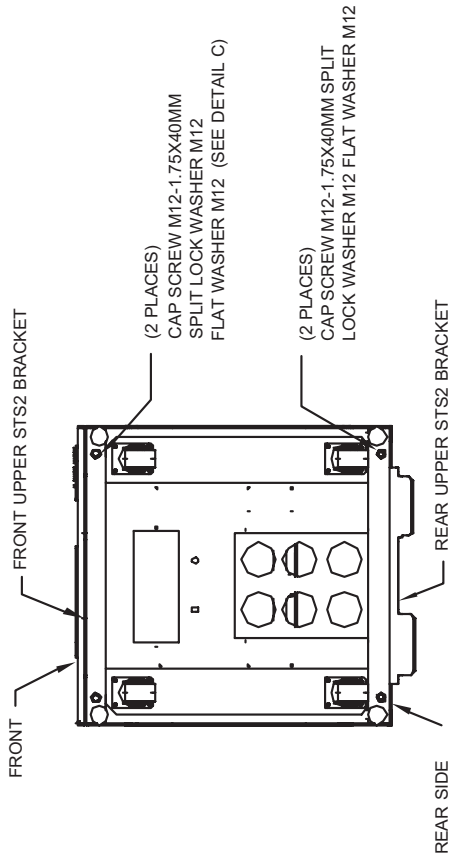

FIG. 1
BOTTOM VIEW OF STS2 WITH UPPER BRACKETS

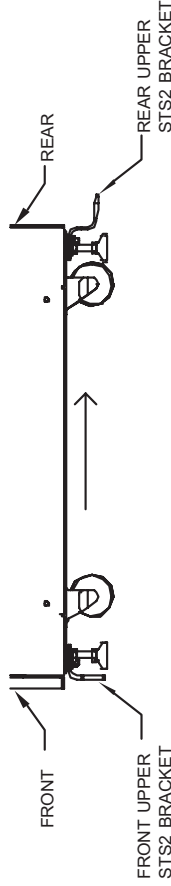
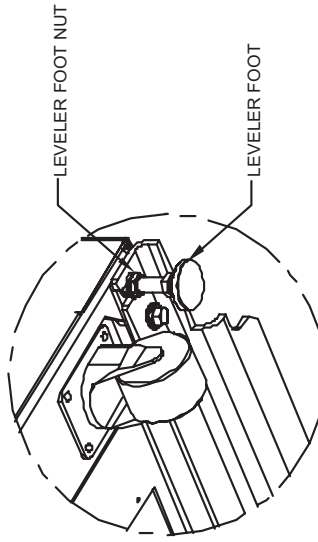

FIG. 2
RIGHT SIDE VIEW OF STS2 WITH UPPER BRACKETS



DETAIL C

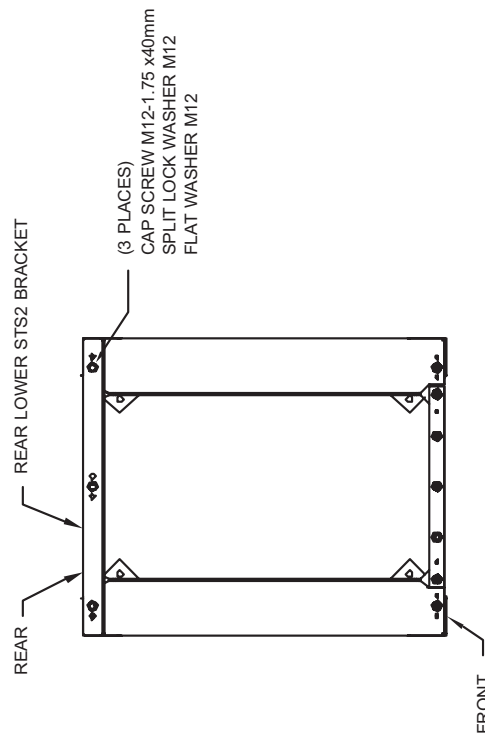

FIG. 3
TOP VIEW OF FLOOR STAND WITH LOWER REAR MOUNTING BRACKET



FIG. 4
RIGHT SIDE VIEW OF FLOOR STAND WITH LOWER REAR MOUNTING BRACKET

INSTALLATION DRAWING
FOR SEISMIC FLOOR STAND
100-250A STS2

PS215001 Rev. 0

Figure 35 Installation drawing, seismic floor stand 100-250A

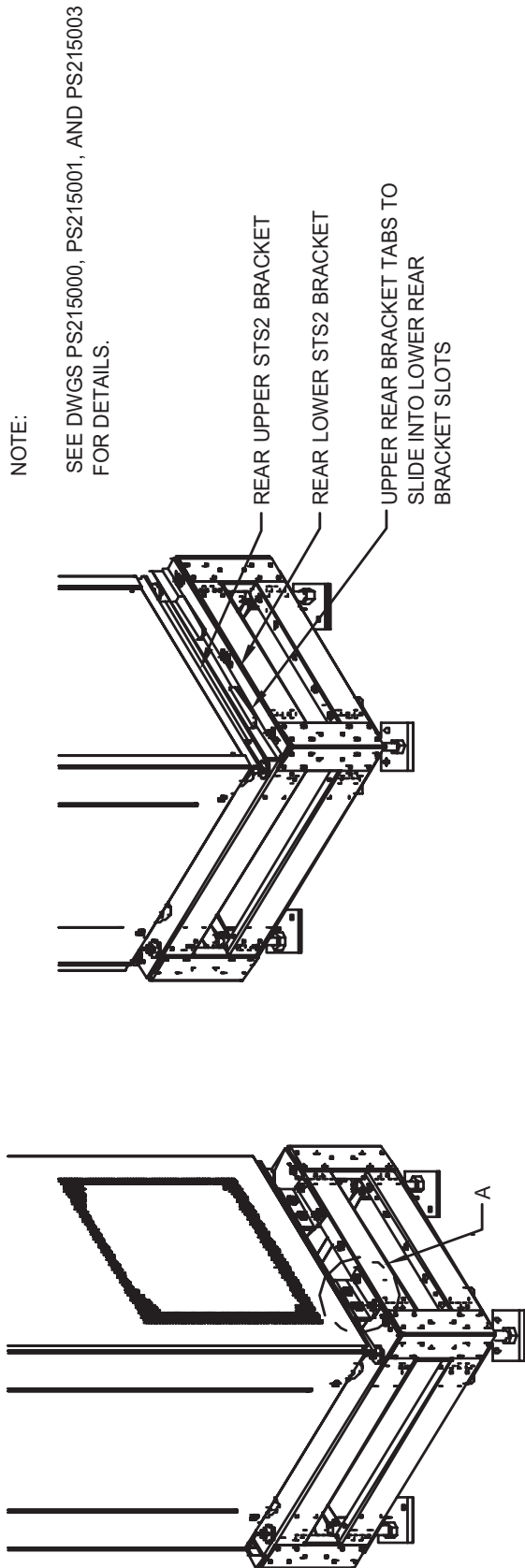
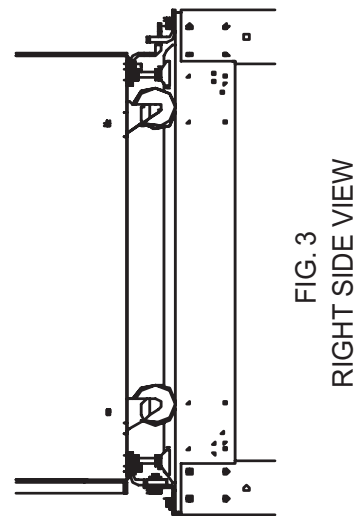
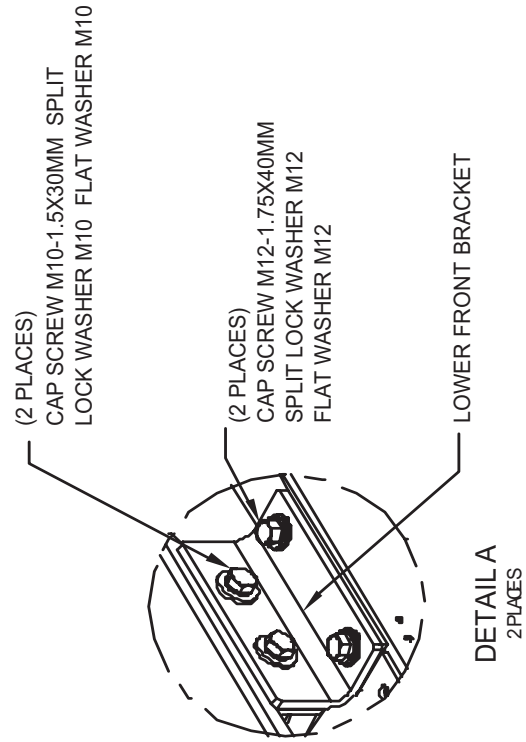

FIG. 2
REAR RIGHT ISOMETRIC VIEW



PS215002 Rev. 0.

Figure 36 Installation drawing, seismic floor stand 100-250A

NOTE:
SEE DWGS PS215000, PS215001, AND PS215002
FOR DETAILS.

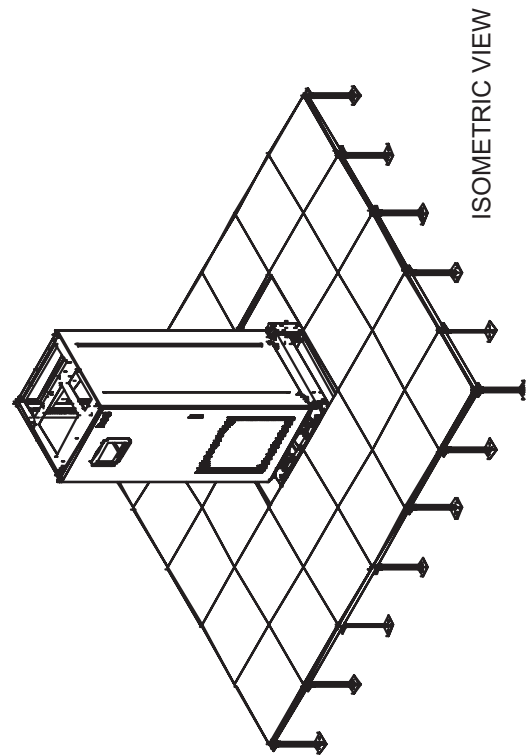
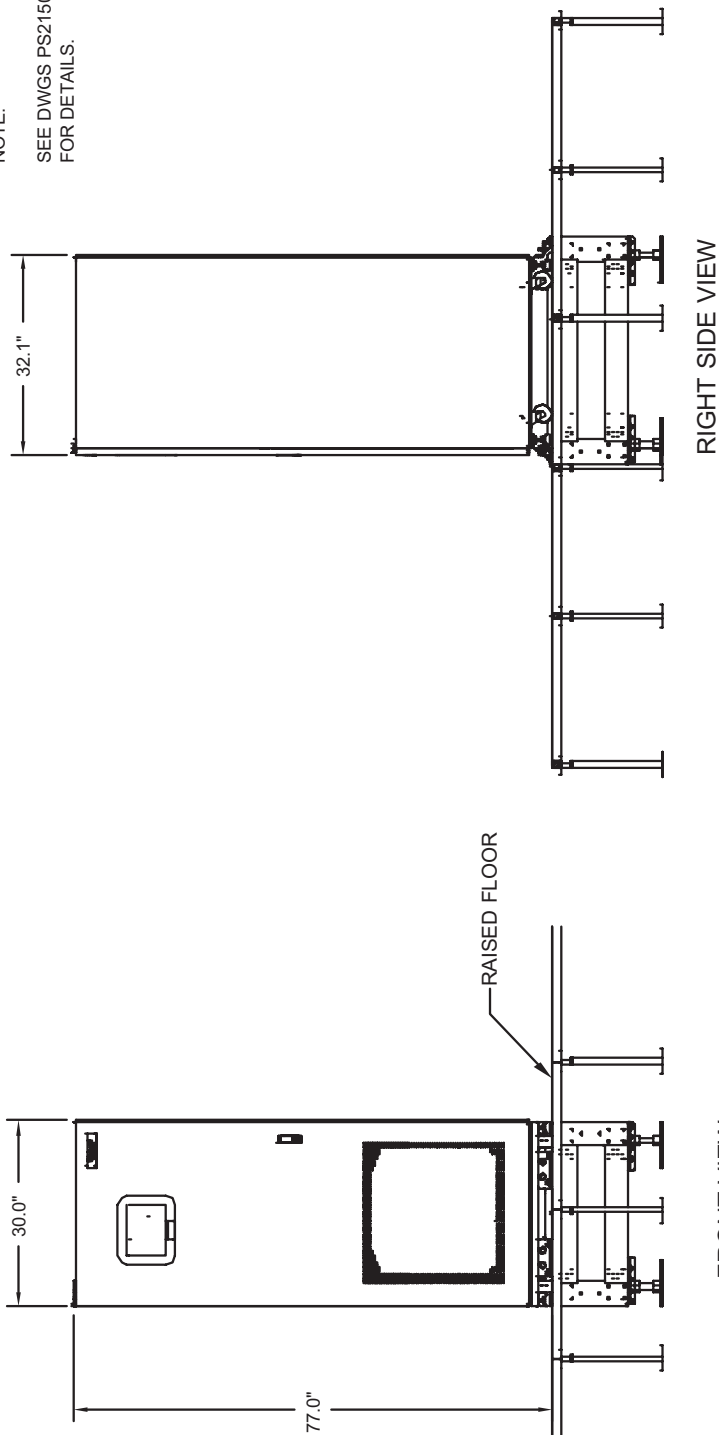

PS215003 Rev. 0

Figure 37 Installation drawing, seismic floor stand 400-600A

- INSTALLATION NOTES:
1. CHECK ALL HARDWARE FOR PROPER TORQUE PRIOR TO INSTALLATION.
 2. INSTALL REAR LOWER STS2 BRACKET TO THE FLOOR STAND USING EXISTING HOLES WITH BENT FLANGE FACING THE FRONT OF THE FLOOR STAND (FIG. 3 AND FIG 4, DWG PS216001). USE M12-1.75X40mm CAP SCREW, SPLIT LOCK WASHER, AND FLAT WASHER AND TORQUE TO 53 FT-LBS.
 3. LOOSEN THE STS2 ADJUSTABLE LEVELER FEET NUTS (SEE DETAIL C; DWG PS216001). INSTALL REAR UPPER STS2 BRACKET USING EXISTING HOLES ON UNDERSIDE OF THE STS2 WITH TABS FACING OUT (FIG 1 AND FIG 2, PS216001). INSTALL FRONT UPPER STS2 BRACKET USING EXISTING HOLES ON UNDERSIDE OF THE STS2 WITH BENT FLANGE FACING TO THE FRONT. (FIG.1 AND FIG 2, PS216001). USE M12-1.75X40mm CAP SCREW, SPLIT LOCK WASHER, AND FLAT WASHER AND TORQUE TO 53 FT-LBS. RETIGHTEN LEVELER FEET NUTS.
 4. FLOOR STAND CAN BE MOUNTED NEXT TO A WALL IF NEEDED. REAR ACCESS NOT REQUIRED. INSTALL FLOOR STAND WITH FEET ORIENTATED AS SHOWN IN (BOTTOM VIEW; DWG PS216000). TO ADJUST VERTICAL HEIGHT OF FLOOR STAND FEET. LOOSEN, ADJUST AND TIGHTEN THE NUTS AND JAM NUT SHOWN IN (FOOT DETAIL A & B; ON DWG PS216000). FLOOR STAND MUST BE LEVEL AND ALL FEET MUST BE TOUCHING THE FLOOR. ATTACH FLOOR STAND FEET USING 1/2" X 4" RED HEAD TRUBOLTS EXPANSION ANCHORS (FEILD SUPPLIED) (2) PER FOOT.

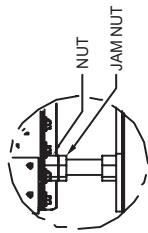

FOOT DETAIL A

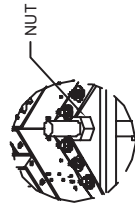

FOOT DETAIL B

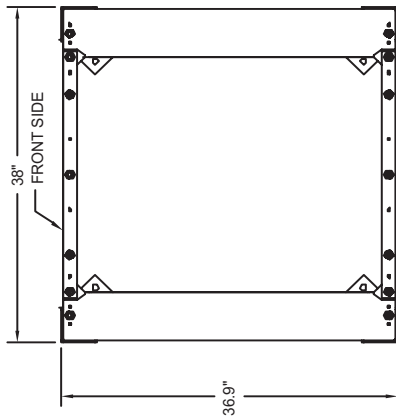

TOP VIEW

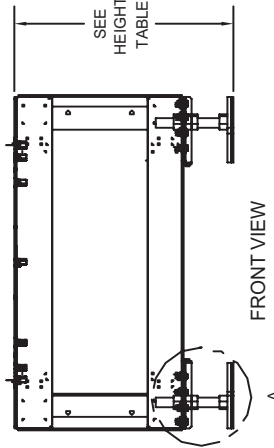

FRONT VIEW

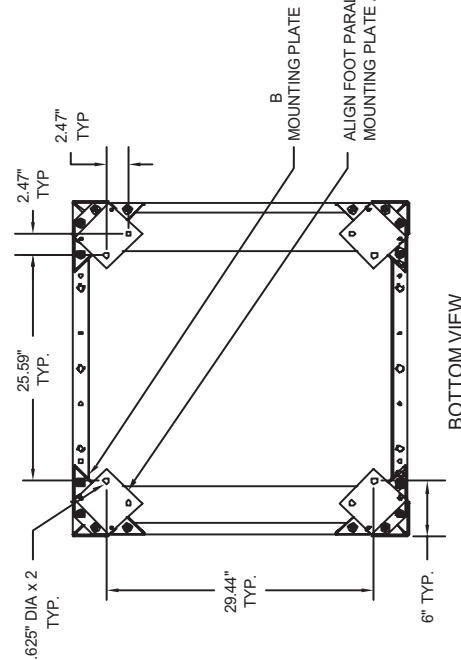

BOTTOM VIEW

HARDWARE TORQUE CHART	
1.0" NUT	320 FT - LBS
M8 - 1.25	16FT - LBS
M10 - 1.5	31 FT - LBS
M12 - 1.75	53 FT -LBS

HEIGHT TABLE			
P/N OF FLOOR STAND:	HEIGHT	HEIGHT MAX:	HEIGHT MIN:
523405G1	18.0"	19.25"	16.75"
523406G1	24.0"	25.25"	22.75"
523407G1	30.0"	31.25"	28.75"
523408G1	36.0"	37.25"	34.75"

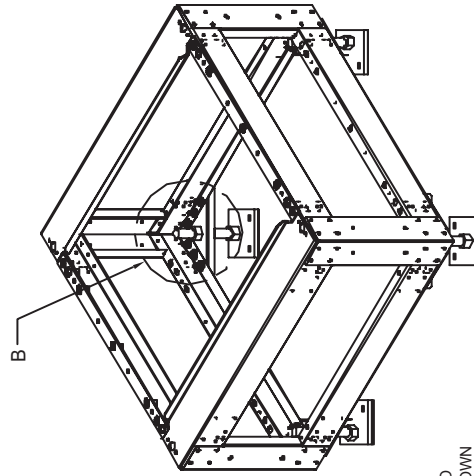

ISOMETRIC VIEW #1

PS216000 Rev.0

Figure 38 Installation drawing, seismic floor stand 400-600A

NOTE:
SEE DWGS PS216000, PS216002, AND PS216003 FOR DETAILS.

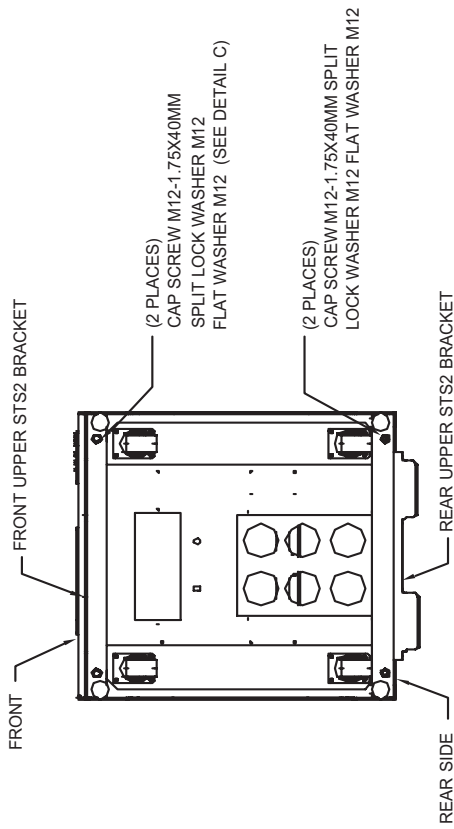

FIG. 1

BOTTOM VIEW OF STS2 WITH UPPER BRACKETS

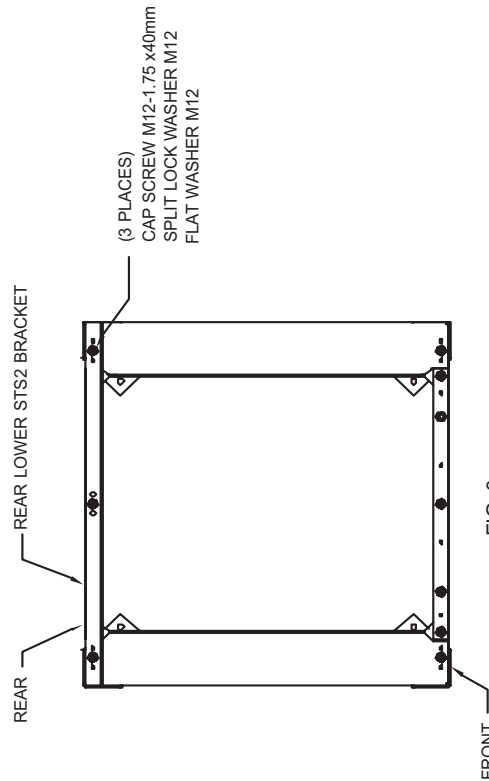

FIG. 3

TOP VIEW OF FLOOR STAND WITH LOWER REAR MOUNTING BRACKET

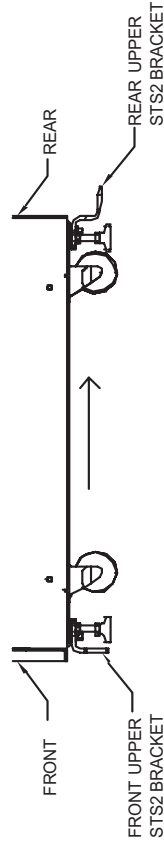
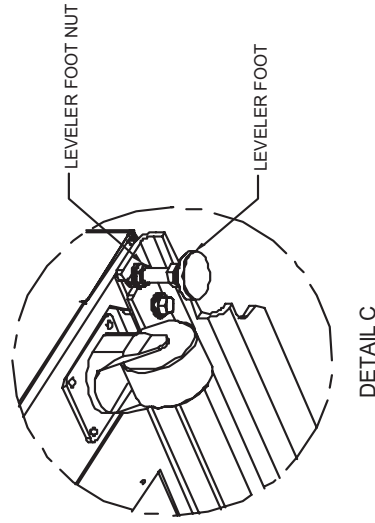

FIG. 2

RIGHT SIDE VIEW OF STS2 WITH UPPER BRACKETS



DETAIL C

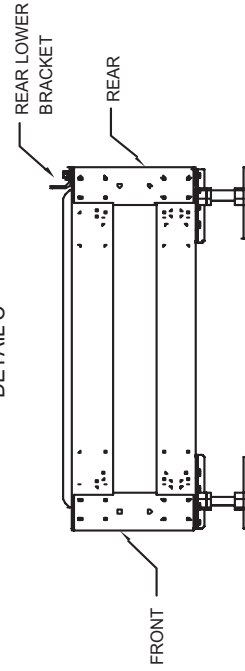

FIG. 4

RIGHT SIDE VIEW OF FLOOR STAND WITH LOWER REAR MOUNTING BRACKET

PS216001 Rev. 0

Figure 39 Installation drawing, seismic floor stand 400-600A

NOTE:

SEE DWGS PS216000, PS216001, AND PS216003 FOR DETAILS.

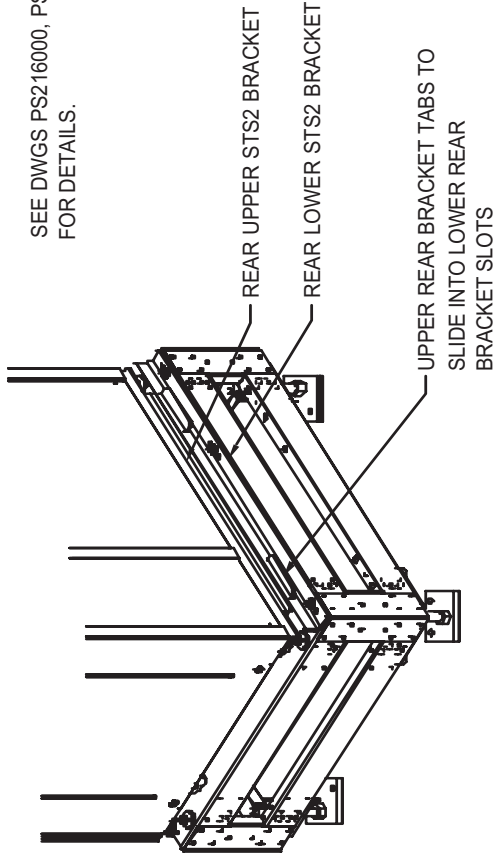

FIG. 2
REAR RIGHT ISOMETRIC VIEW

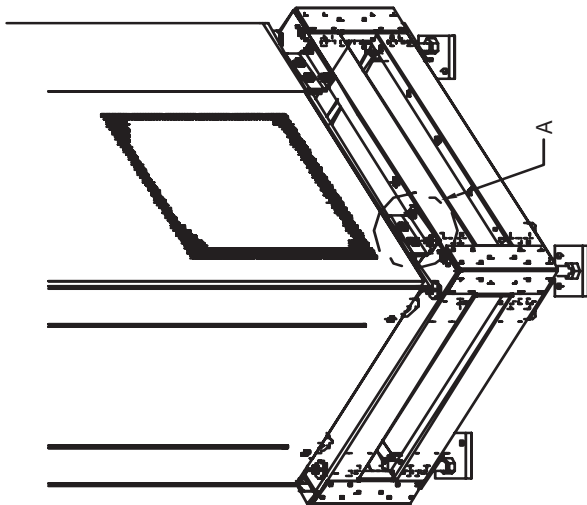
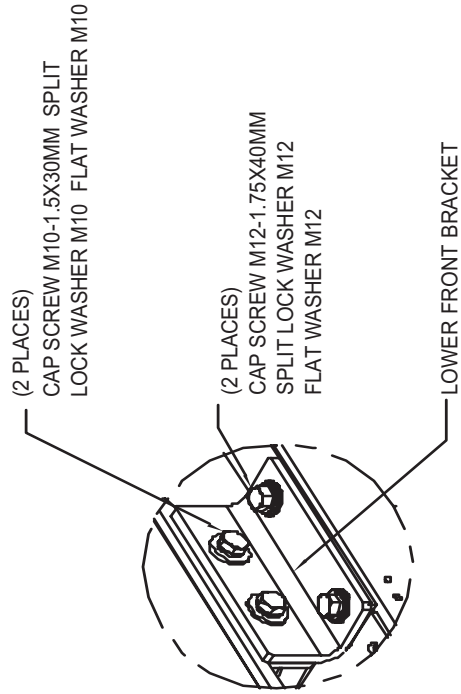

FIG. 1
FRONT LEFT ISOMETRIC VIEW



DETAIL A
2 PLACES

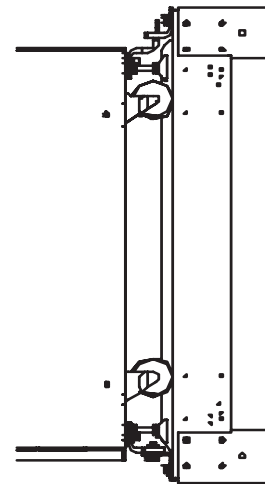
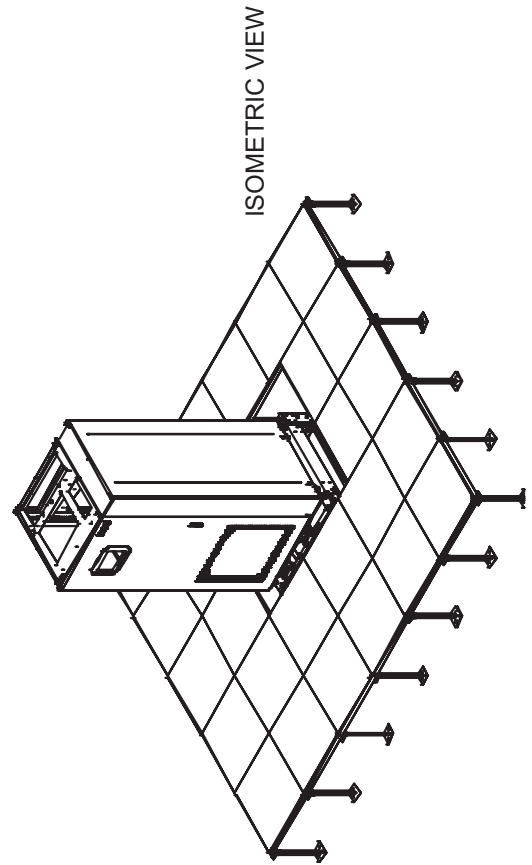
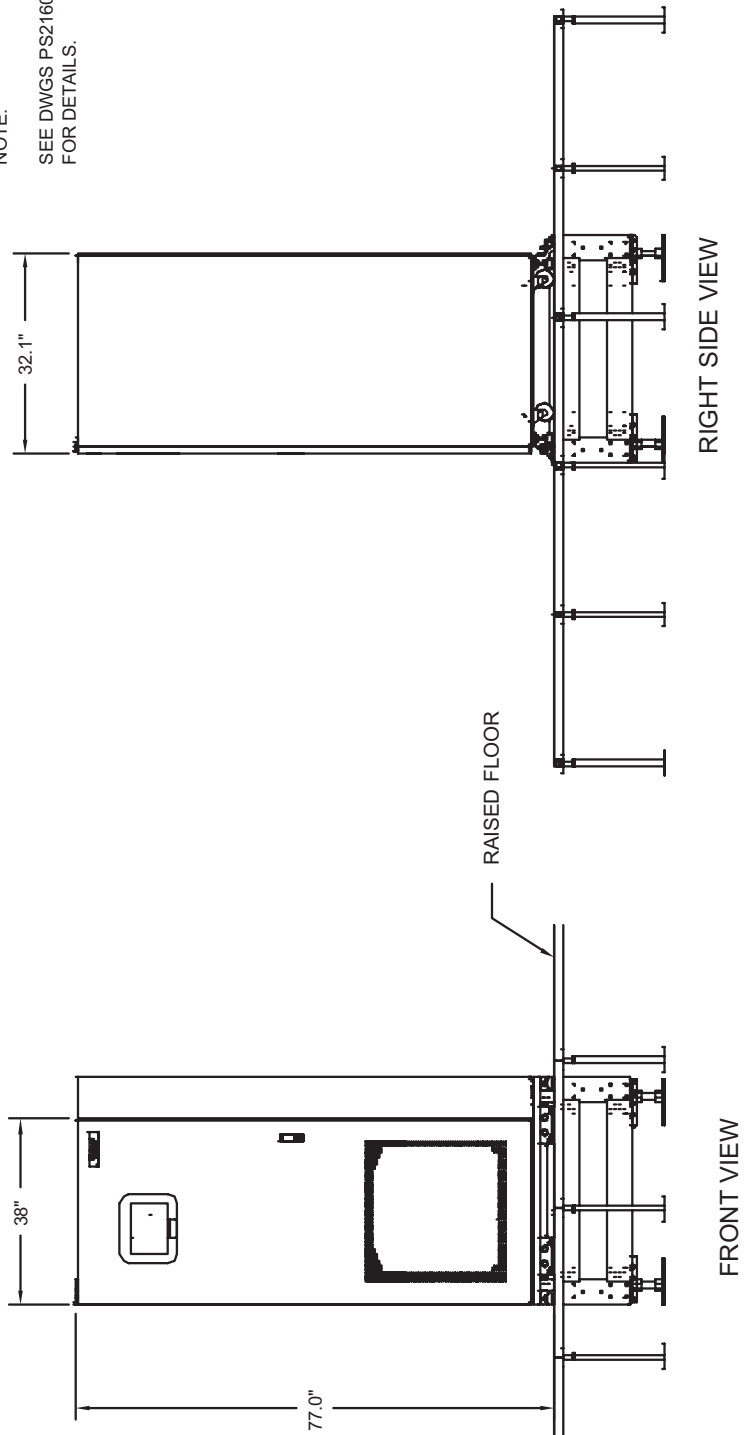

FIG. 3
RIGHT SIDE VIEW

PS216002 Rev. 0

Figure 40 Installation drawing, seismic floor stand 400-600A

NOTE:
SEE DWGS PS216000, PS216001, AND PS216002
FOR DETAILS.



PS216003 Rev. 0

Figure 41 Installation drawing, seismic floor stand 800-1000A

INSTALLATION NOTES:

1. CHECK ALL HARDWARE FOR PROPER TORQUE PRIOR TO INSTALLATION.
2. INSTALL REAR LOWER STS2 BRACKET TO THE FLOOR STAND USING EXISTING HOLES WITH BENT FLANGE FACING THE FRONT OF THE FLOOR STAND (FIG. 3 AND FIG 4, DWG PS217001). USE M12-1.75x40mm CAP SCREW, SPLIT LOCK WASHER, AND FLAT WASHER AND TORQUE TO 53 FT-LBS.
3. LOOSEN THE STS2 ADJUSTABLE LEVELER FEET NUTS (SEE DETAIL C; DWG PS217001). INSTALL REAR UPPER STS2 BRACKET USING EXISTING HOLES ON UNDERSIDE OF THE STS2 WITH TABS FACING OUT (FIG 1 AND FIG 2, PS217001). INSTALL FRONT UPPER STS2 BRACKET USING EXISTING HOLES ON UNDERSIDE OF THE STS2 WITH BENT FLANGE FACING TO THE FRONT. (FIG 1 AND FIG 2, PS217001). USE M12-1.75x40mm CAP SCREW, SPLIT LOCK WASHER, AND FLAT WASHER AND TORQUE TO 53 FT-LBS. RETIGHTEN LEVELER FEET NUTS.
4. FLOOR STAND CAN BE MOUNTED NEXT TO A WALL IF NEEDED. REAR ACCESS NOT REQUIRED. INSTALL FLOOR STAND WITH FEET ORIENTATED AS SHOWN IN (BOTTOM VIEW; DWG PS217000). TO ADJUST VERTICAL HEIGHT OF FLOOR STAND FEET, LOOSEN, ADJUST AND TIGHTEN THE NUTS AND JAM NUT SHOWN IN FOOT DETAIL A & B; ON DWG PS217000. FLOOR STAND MUST BE LEVEL AND ALL FEET MUST BE TOUCHING THE FLOOR. ATTACH FLOOR STAND FEET USING 1/2" X 4" RED HEAD TRUBOLTS EXPANSION ANCHORS (FIELD SUPPLIED) (2) PER FOOT.
5. ROLL THE STS2 ONTO THE FLOOR STAND SO THAT THE TABS ON THE (REAR UPPER STS2 BRACKET) FIT INTO THE SLOTS ON THE (REAR LOWER STS2 BRACKET). TABS TO EXTEND AT LEAST 1/2" THROUGH FLOOR STAND BRACKET (FIG. 2, DWG PS217002).
6. INSTALL THE LOWER FRONT BRACKETS (FIG 1, DETAIL A; DWG PS217002). ATTACH BRACKET TO STS2 USING M10-1.50x30mm CAP SCREW, SPLIT LOCK WASHER, AND FLAT WASHER AND TORQUE TO 31 FT-LBS. ATTACH BRACKET TO FLOOR STAND USING M12-1.75x40mm CAP SCREW, SPLIT LOCK WASHER, AND FLAT WASHER AND TORQUE TO 53 FT-LBS

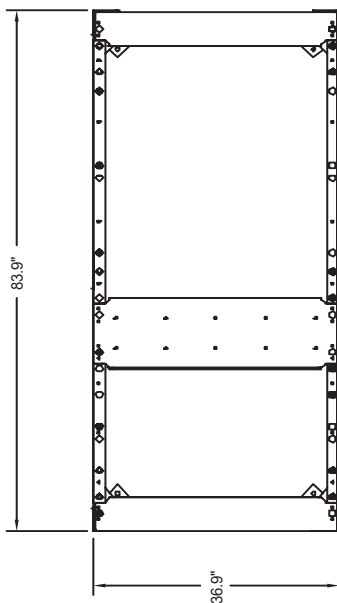

TOP VIEW

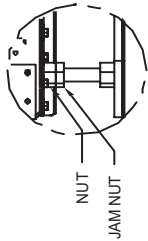

FOOT DETAIL A



FOOT DETAIL B

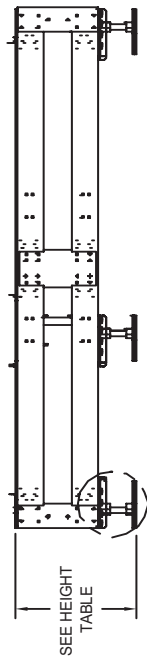

FRONT VIEW

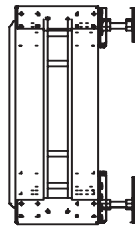

RIGHT SIDE VIEW

HARDWARE TORQUE CHART	
1.0" NUT	320 FT - LBS
M8 - 1.25	16FT - LBS
M10 - 1.5	31 FT - LBS
M12 - 1.75	53 FT - LBS

HEIGHT TABLE			
P/N OF FLOOR STAND:	HEIGHT	HEIGHT MAX:	HEIGHT MIN:
523409G1	18.0"	19.25"	16.75"
523410G1	24.0"	25.25"	22.75"
523411G1	30.0"	31.25"	28.75"
523412G1	36.0"	37.25"	34.75"

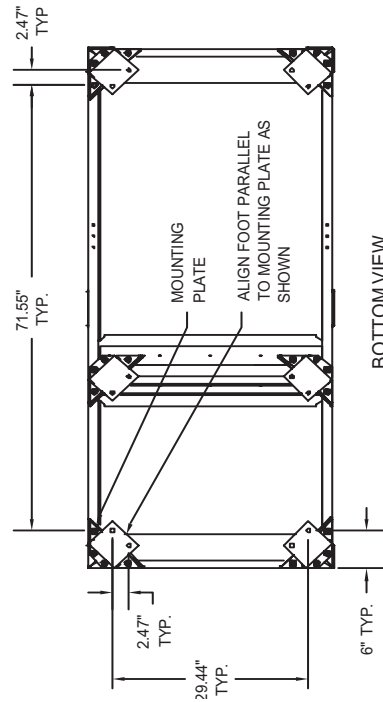

BOTTOM VIEW

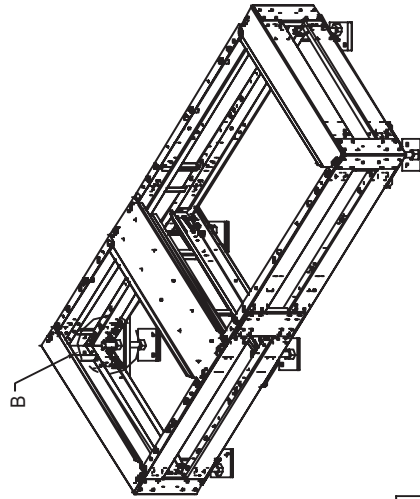

ISOMETRIC VIEW

PS217000 Rev. 0

Figure 42 Installation drawing, seismic floor stand 800-1000A

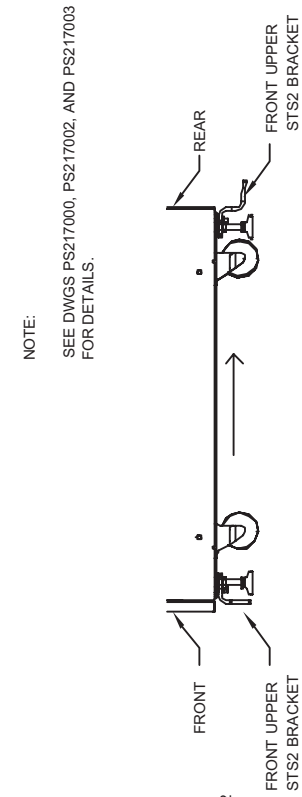

FIG. 2
RIGHT SIDE VIEW OF STS2 WITH UPPER BRACKETS

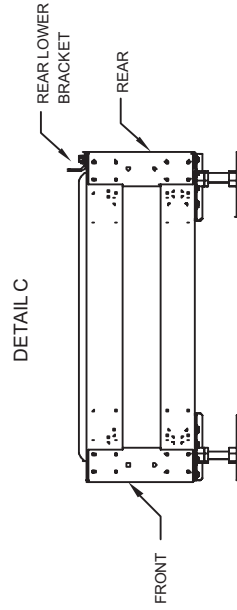
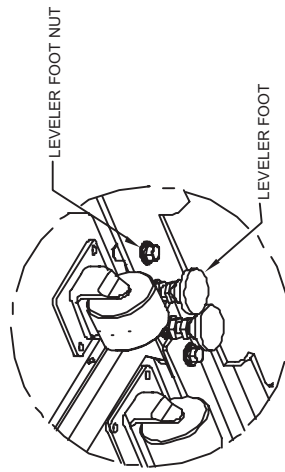

FIG. 4
RIGHT SIDE VIEW OF FLOOR STAND
WITH LOWER REAR MOUNTING BRACKET

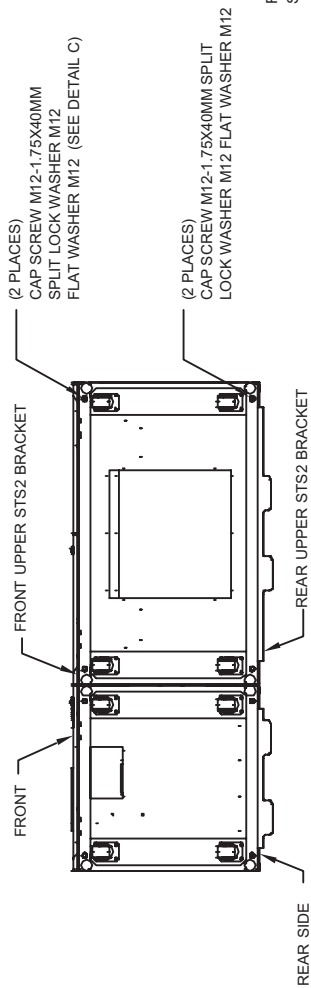

FIG. 1
BOTTOM VIEW OF STS2 WITH UPPER BRACKETS

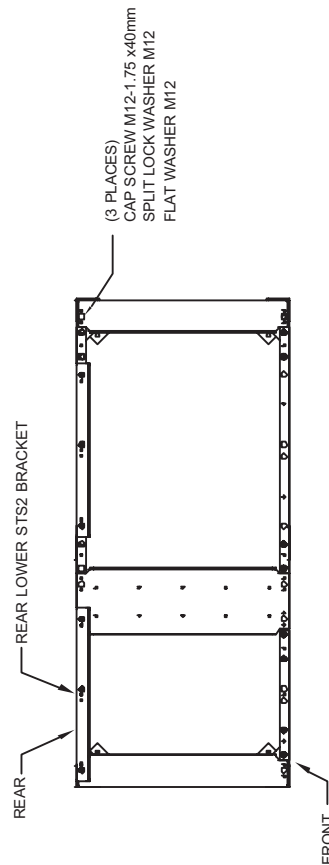
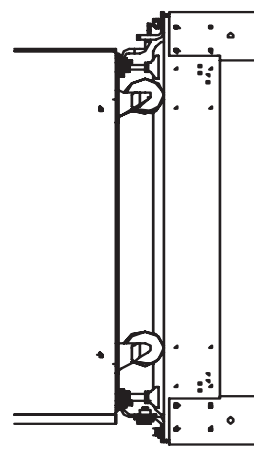
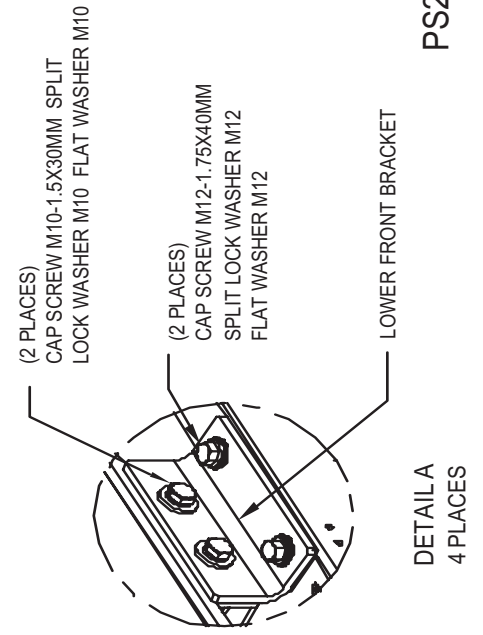
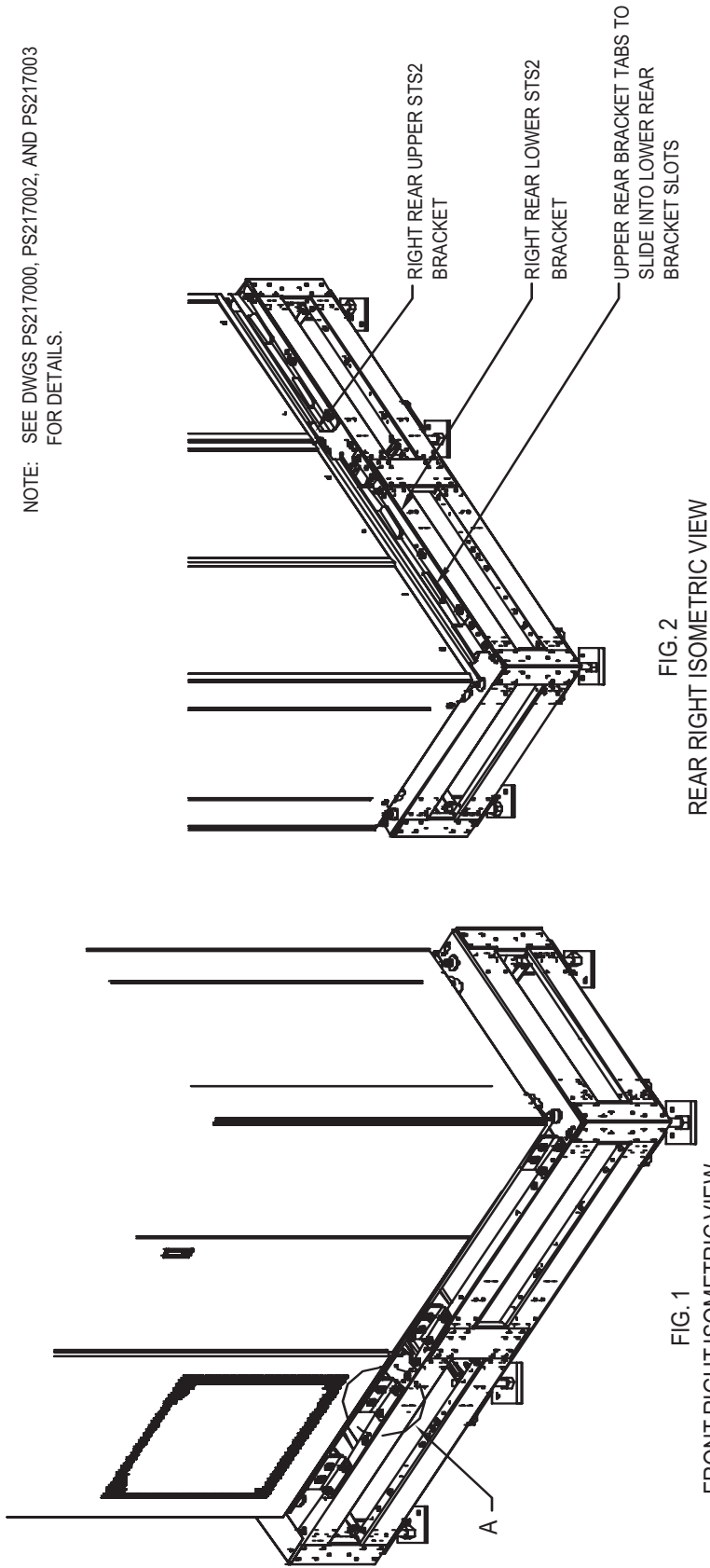

FIG. 3
TOP VIEW OF FLOOR STAND
WITH LOWER REAR MOUNTING BRACKET

PS217001 Rev. 0

Figure 43 Installation drawing, seismic floor stand 800-1000A

NOTE: SEE DWGS PS217000, PS217002, AND PS217003 FOR DETAILS.



PS217002 Rev. 0

Figure 44 Installation drawing, seismic floor stand 800-1000A

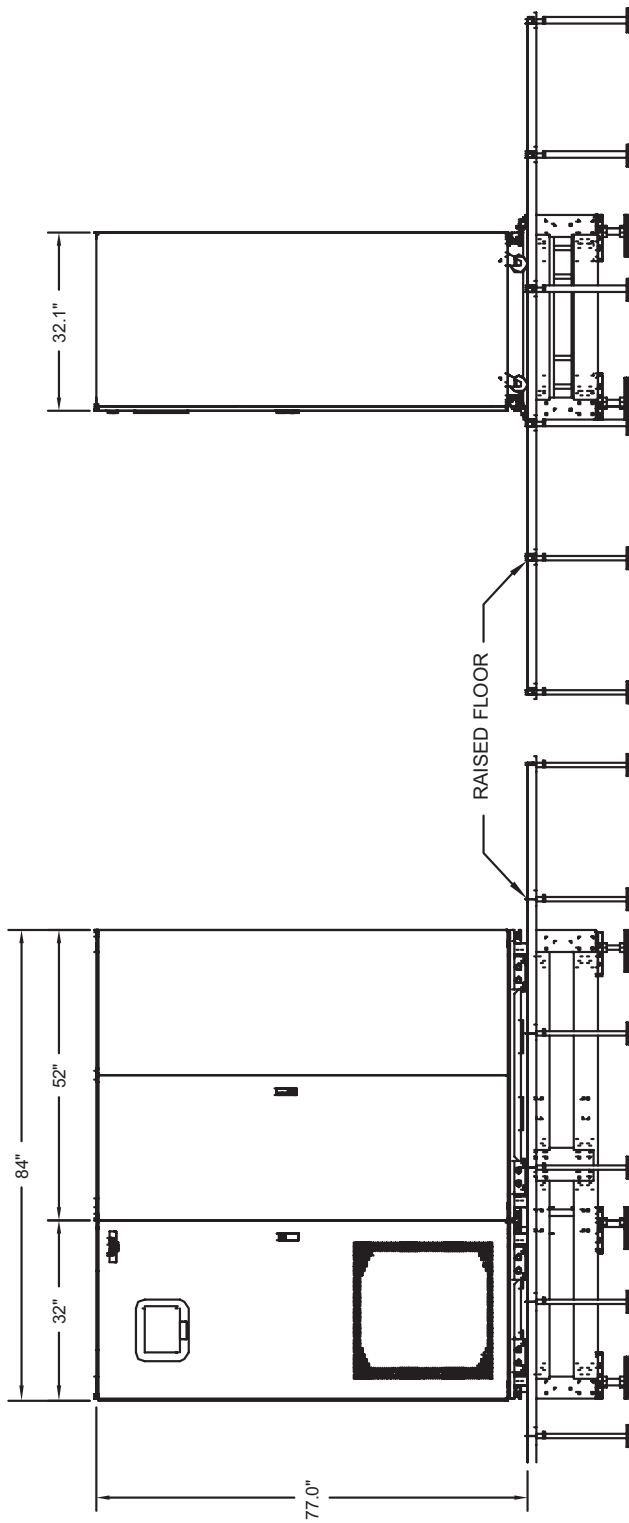

RIGHT SIDE VIEW

FRONT VIEW

NOTE:

SEE DWGS PS217000, PS217001, AND PS217002 FOR DETAILS.

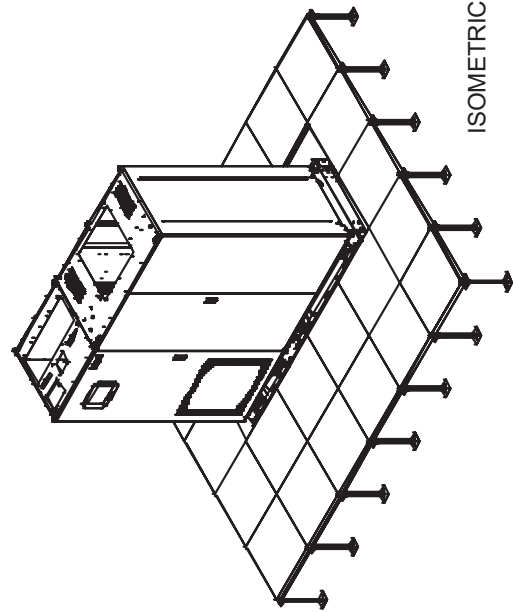

ISOMETRIC VIEW

PS217003 Rev. 0

8.0 INTRODUCTION TO STS2 OPERATIONS

8.1 System Description

A STS2 provides an automatic, seamless transfer between input power sources to an output load. The STS2 monitors the input sources, to ensure each source is operating within set parameters, as well as ensure that each source is within acceptable tolerances for a transfer between sources to be completed.

The STS2 contains two static transfer switches in one enclosure to allow the unit to transfer its load between the two input sources without disruption to the output for longer than 1/4 cycle.

If a problem is detected with a primary (*Preferred*) input source and defined trigger points are reached, the STS2 automatically switches the input to the other (*Alternate*) input source. The STS2 continues to monitor both sources and can automatically transfer the load back to the preferred source, if so configured, when that source returns to acceptable operating parameters.

The system control logic automatically monitors the input sources and power output to ensure that they are operating within acceptable tolerances. The system logic manages the transfer between sources.

The STS2 front panel contains either a Color Graphical Display on an LCD touch screen or an LED display.

The Color Graphical Display provides a menu-driven operator interface, and a display of system information, status information, a one-line diagram (*Mimic*) of the STS2, active alarms, and alarm history information.

The menu selections provide control of the preferred source, manual transfer initiation. Buttons provide for audible alarm silence and reset.

Through the touch screen, specific voltage, current and environmental parameters can be configured to trigger events that can sound an alarm, write to a history log and either transfer sources or inhibit a transfer.

In units not equipped with the touch screen, LEDs provide the user with the ability to monitor the STS2 and quickly assess problems.

Preferred input source selection, alarm reset and alarm silencing are done through buttons on the touch screen, or push buttons with the LED display.

Communication options can be installed in the Color Graphical Display (LCD) unit only. These options provide external communication with the STS2 through a modem, a network card, a programmable relay board, a contact isolator, or an RS-422 port to Liebert's SiteScan.

8.1.1 Redundancy

Redundancy within the STS2 prevents one component from being a single point of failure, should a problem occur. Redundant circuits and components are used to eliminate single points of failure.

Since the STS2 has two input sources, no single component failure can cause a loss of power to the load. Redundant power supplies are provided which feed a DC dual-bus used throughout the unit to prevent any single-point power supply failure modes.

Three separate redundant control logic modules are built into the system. Each contains the logic necessary to run the STS2, and control all transfers.

Redundant fans are provided if a primary fan fails. The redundant fans turn on to prevent overheating inside of the unit.

Should the front panel interface fail, either touch screen or LEDs, the control logic continues to operate and the unit would transfer should a problem be detected on the preferred source. Information on the monitoring parameters would be available through the remote communication options, if available, or the DB9 (RS-232) connector located next to the LCD display behind the front door. See **Figure 29** on page 41 for details.

8.1.2 Reliability and Agency Requirements

The STS2 is designed for high reliability and high availability with a critical bus Mean Time Between Failure (MTBF) exceeding 1,000,000 hours.

The STS2, Control/Power Module, and all its options are designed, tested and certified, where applicable, to meet agency requirements as follows:

- UL 1008: Transfer Switch Equipment, for UL and ULc listing
 - UL1459: Telephone equipment (Modem)
 - NEC
 - FCC Part 15 EMI emission limits for Class A computing devices.

The STS2 uses conservatively rated components, minimizing the need to go to maintenance bypass. All maintenance and repair work can be done through the front panel of the unit. This access makes repairs and maintenance easier.

Gating and control logic are partitioned so that failure of one source's gating or sensing logic does not prevent the switch from transferring to the other source.

All control and logic components are mounted separate from the power components. The STS2 is designed to minimize the exposure of hazardous voltages to allow safe servicing of the unit while the load is energized.

All electrical components requiring normal maintenance are replaceable without de-energizing the load, as long as one source is available. Solid-state switching devices are packaged to allow safe repair of those devices without having to de-energize the load. All non-automatic switches or circuit breakers are the plug-in or draw-out type to allow replacement without de-energizing the load. All solid-state power switching devices are rated to prevent hazardous device failure in power systems with available fault currents up to the defined limits, as listed in **15.1.5 - Electrical Requirements**.

8.1.3 Factory Backup and Service Assistance

Because improper installation can cause a system to fail, a Liebert Global Services service technician should thoroughly inspect the unit to ensure it is properly installed and its operating parameters are properly configured.

Once the STS2 is properly installed, you, as the on-site operator, can easily monitor the unit's operation utilizing the touch screen or LEDs.

If you need assistance, or have questions, you can contact Liebert for technical support at 1-800-LIEBERT (800-543-2378).

8.2 Modes of Operation

8.2.1 Normal (Preferred Source)

Under normal operating conditions, the STS2 routes power from the preferred input source to the output load. The unit monitors the voltage current and phase of each source to ensure that both are operating within set tolerances, and that the alternate source is available, should a transfer be required

8.2.2 Transfer

Should the preferred source fail or be outside acceptable voltage limits, the STS2 transfers the input to the alternate source until the problem is rectified in the preferred source. The unit can be set to automatically transfer the input back to the preferred source, or only allow the transfer to be done manually.

8.2.3 Transfer Inhibit

For a transfer to be completed between input sources, the sources must meet certain parameters, or the transfer cannot take place. Uninterrupted transfer between sources is inhibited due to input source failure, sources out of sync, switch failure, or the unit is in bypass mode.

8.2.4 Bypass

The static transfer switch can be manually bypassed to allow the power from a source to directly flow to the output load. This bypass allows the unit's electronics to be serviced without dangerous voltages being present.

The STS2 includes key-interlocked maintenance bypass breakers that allow either input source's electronics to be bypassed for maintenance without interruption of power to the load. The maintenance bypass allows all electronics to be isolated from the input, output, and bypass connections. Bypass instructions are available from the touch screen and are discussed later in this manual.

8.3 Operator Controls

The STS2 is equipped with an interface to configure and monitor the unit either locally or remotely. The Color Graphical Display is a touch screen LCD that provides a color diagram (Mimic) that displays the current status of the unit. System parameters are displayed and help is available to define events. See **Figure 45** below and **Figure 31**. The touch screen menus allow the operator to initiate source transfers, view event and history logs, and view bypass and other operational instructions.

Figure 45 STS2 touch screen display

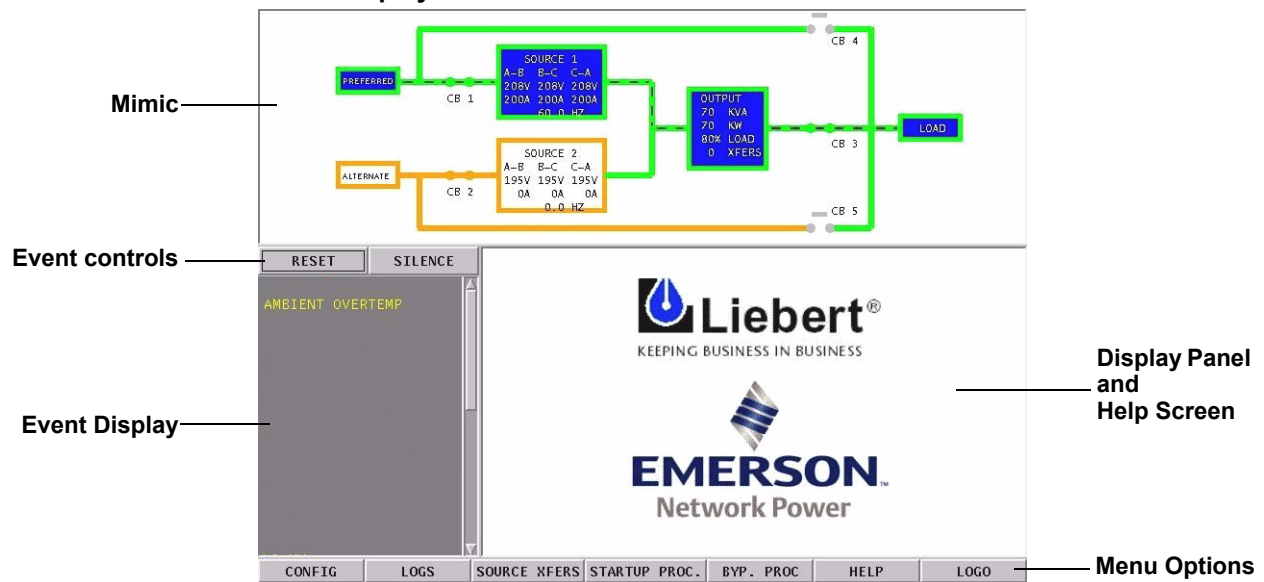

Touch screen control buttons allow you to reset alarms, silence the audible alarm, review configurations, event and history logs, preferred source, startup and bypass procedures, and the help menu. Qualified personnel, with a password, can use these menus to configure parameters, select a preferred source, and do manual source transfers.

LED display units do not have the color LCD display. Instead of the touch screen, these units are monitored by a series of LEDs and controlled by a series of push buttons.

Both units can be accessed from a terminal, or a PC running terminal emulation software, that is attached to the unit. Through the RS-232 access, you can monitor and configure the unit, plus remotely select a preferred source. See **12.1 - Using the RS-232 Port** on page 76 for instructions on using the RS-232 interface.

9.0 THEORY OF OPERATION

9.1 General Description

The STS2 contains all the equipment necessary to prevent an interruption in power flow to the AC load, should your primary source fail.

9.1.1 STS2 Static Transfer Switch

The STS2 is a 3 pole, double-throw, solid state automatic transfer switch that is fed from two sources. The *Preferred* source is the input source that normally carries the load when both sources are available. The preferred source is selectable by the user from the LCD panel or an optional Remote Source Selection. The unselected source is referred to as the *Alternate* source and carries the load if the preferred source should fail or if a manual transfer is initiated.

The unit uses Silicon Controlled Rectifiers (SCRs) connected in paralleled, opposing pairs to function as an AC switch configuration. Three pairs of SCRs connect the AC load to the selected preferred input source as long as the preferred source is available. A second set of SCRs stands ready to transfer the AC load to the alternate input source should the preferred source fail. The switching action is a very fast, break-before-make with less than a 1/4 cycle break in the AC waveform.

During static switch transfers and retransfers, the conduction state of the SCRs is carefully monitored and controlled to prevent a current path from one source to the other. This technique prevents a faulted source from feeding into the other good source.

9.1.2 Source Transfer

The STS2 allows manually initiated transfers between the two sources, providing the alternate source is within acceptable voltage limits and phase tolerances with the preferred source. You begin a manual transfer by selecting the inactive source as the preferred source. On a manual transfer, the STS2 transfers between the two sources with less than one (1) millisecond interruption of power to the load. The transfer can only be completed when both sources are available and synchronized within the user-adjustable phase synchronization window. For sources where the two frequencies are not exactly in phase, manually-initiated transfers are delayed by the STS2 until the two sources are within the defined phase synchronization window.

Source selection can also be done remotely using the Remote Source Selection option, if installed.

9.1.3 Automatic Transfer/Retransfer

If the preferred source is out of voltage and/or frequency limits, the load is automatically transferred to the alternate source. The default transfer voltage limits comply with the limits of the IEEE Std. 446-1995 computer voltage tolerance envelope.

If the unit is so configured, the load is retransferred automatically to the preferred source after the preferred source returns to within the acceptable voltage and frequency limits for at least the defined retransfer time delay, and is in phase with the alternate source. You can enable and disable automatic retransfer to the preferred source through a user configuration setting.

Automatic Retransfer Inhibited

If the system makes five transfers from the preferred source to the alternate source in a five minute period, automatic retransfers back to the preferred source is disabled.

To clear this alarm condition, you must assign the alternate source as the preferred source.

Also, the UV detection thresholds may need adjustment. See **Source Set Points on page 90** for instructions on setting the UV detection.

This alarm also is cleared if the unit transfers to the preferred source due to an alternate source AC volt failure (i.e., an emergency transfer.)

9.1.4 Emergency Transfer

To ensure that power remains connected to the load, the STS2 automatically performs an emergency transfer from one input source to the other when an outage occurs on the existing source. The automatic transfer takes place if the other source's voltage is within acceptable limits, and regardless of the phase difference between the two sources.

Emergency transfers occur with a loss of power on the output of less than 4 ms.

Emergency transfers from the alternate source to the preferred source are not affected by the Auto Retransfer Enabled/Disabled or Retransfer Delay user settings.

9.1.5 Load Current Transfer Inhibit

The STS2 senses the load current. If the load current exceeds the preset level deemed to represent a load inrush or fault condition, the unit's logic disables manual and automatic transfers, even if the selected source's input voltage is outside the acceptable limits. This event triggers an I-Peak alarm. If so configured, the Load Current Transfer Inhibit is automatically reset after the current and voltage return to within normal parameters. This reset provides continued protection against a source failure. The Load Current Transfer Inhibit also can be programmed to require a manual reset. See **step 14**, on page 92 under the **Source Set Points** heading for details.

9.1.6 SCR Failure

The STS2 continuously monitors the status of the SCR switching devices for proper operation. In the event of a shorted SCR on the input source powering the load, the STS2 automatically triggers an alarm and trips open the other source isolation breaker. In the event of a shorted SCR on the other input source, the STS2 automatically triggers an alarm and trips open the other source isolation breaker.

In the event of an open SCR, the switch automatically triggers an alarm and transfers the load to the other source. All open and shorted SCR alarm conditions are latched and require the system to be repaired and reset to restore normal operation.

9.1.7 On/Off Sequence

The STS2 contains no master On/Off push button control. When connected to the input sources, the unit's logic power comes on automatically. The touch screen display (if so equipped) is active as long as at least one input source is energized and the Control Power Disconnect (located inside the static switch) is on.

9.2 Detailed Component Description

9.2.1 Controls

Operator Interface

The STS2 Color Graphical Display unit contains a touch screen color LCD to provide the operator interface to control and configure the operation of the unit and quickly diagnose problems. A password and an optional keylock, if installed, are provided for security.

The LED Display unit includes push-buttons for source transfer, alarm reset and audible alarm silence.

Hardware

- The STS2 operator interface in the Color Graphical Display unit is designed to provide all of the information required to configure and monitor the unit's operation.
- The control logic performs automatic operations with minimal operator interface.
- Each STS2 unit is equipped with either a color LCD touch screen or a panel of LEDs and push buttons.
- The STS2 can have optional communication ports installed. See **6.0 - Options** and **12.0 - Communication Interfaces** on page 76 for more information on communication options.
- On LED Display units, the RS-232 interface is used for configuration and status and event log monitoring. The RS-232 interface can also be used with the Color Graphical Display units, if necessary.

Firmware

The operator interface enables you to monitor the STS2, to configure set points for transfers, monitor system parameters and access event and history logs. The firmware is accessible through the LCD touch screen (if installed) or the RS-232 interface. The firmware includes:

- View and set the preferred source.
- View and configure set points.
- View alarms, faults and status.

Additionally, the Color Graphical Display unit provides:

- The mimic graphical representation of the systems operation.
- Menu driven monitoring and configuration.
- Step-by-step instructions to assist you in the start-up, shut-down and bypass operations.
- Help on event messages.
- Touch screen alarm reset and silence buttons.

Events in the system, both faults and alarms, are detected and displayed on the LCD. See **11.0 - Alarm and Faults** on page 71 for more information on events.

- A set of event masks can be configured through the LCD to trigger a system response to an event. See **11.1 - Event Mask**.
- Report event conditions from other components of the system.
- Monitor and report changes in event condition states. If the event condition's state changes from *inactive* to *active*, a new event is detected. If the transition is from *active* to *inactive*, the event condition has cleared.
- Process new faults and alarms, and clear inactive alarms.
- Provide the alarm reset and silence options.

9.2.2 Circuit Breakers

Three circuit breakers provide total isolation of the solid-state switching devices with an input breaker for each source and a load isolation breaker. Two breakers provide for maintenance bypassing of the solid-state switching devices to either input source.

All switches in the STS2 are plug-in types, which allows any switch to be replaced without de-energizing the output bus. The Merlin Gerin breakers have an interlock in the plug-in base, which prevents the switch from being withdrawn in the CLOSED position. The switch trips OPEN before it disconnects from the plug-in base.

See **15.2.5 - Circuit Breakers** for specifications and more information pertaining to the circuit breakers. See **Figure 14** to **Figure 19** for circuit breaker locations. The circuit breaker schedule is provided in **Figure 20**.

9.2.3 SCRs

Brick-type SCRs are used rated to carry the full 100% rated load. Because the unit is a fuseless design with non-automatic circuit breakers, overcurrent protection is provided by upstream circuit breakers.

9.2.4 Logic Modules

The logic contains three separate redundant logic modules. The modules contain the logic necessary to run the STS2 and control transfers and shunt trips under all circumstances, without any outside assistance once set-up and started properly.

9.2.5 Audible Alarm

An audible alarm is installed on the control board. This alarm is triggered by an alarm condition detected on the unit. The alarm can be turned off from the touch screen (Color Graphical Display units) or by a push button (LED Display units). Turning off the audible alarm does not clear or reset the condition that triggered the alarm.

9.2.6 RS-232 Port

An RS-232 serial port is provided to allow an external terminal to be connected as another user interface. See **12.1 - Using the RS-232 Port** on page 76 for more information on using the RS-232 port.

10.0 OPERATING INSTRUCTIONS FOR THE TOUCH SCREEN INTERFACE



CAUTION

Before unit is placed into service for the first time, after equipment relocation, or after the equipment has been de-energized for an extended period of time, a thorough equipment inspection and supervised start-up by qualified personnel are strongly recommended. Contact your local Liebert representative or Liebert Global Services at 1-800-543-2378 to arrange for equipment inspection and start-up.

After the initial equipment start-up, the following operating guidelines can be used for standard equipment operation. These guidelines should be reviewed for any special equipment modifications, special site conditions, or company policies that may require changes to the standard equipment operation.

All programmable functions are preset at the factory to enable the unit to be brought up without the need to enter all selectable parameters.

This section refers to the LCD touch screen display. This display is discussed in more detail later in the manual. See **13.0 - STS2 Touch Screen Display**.



NOTE

*If the front panel of your STS2 is comprised of LEDs and push buttons instead of the touch screen interface, refer to **14.0 - Operating the LED Display STS2** for operating instructions.*

See **Figures 14- 19** for circuit breaker locations.

10.1 Normal System Turn-On



NOTE

If your STS2 is connected to a PDU with a Wye configuration, enable the Wye Output Transformer before starting the system. This setting can be made from the touch screen. Refer to **Wye Output Transformer on page 100** for instructions.

1. Ensure that all STS2 breakers—CB1, CB2, CB3, CB3A (if supplied), CB4, and CB5—are in the OFF position.
 - a. Ensure that the key interlocks for CB1 and CB2 have their bolts retracted.
 - b. Ensure that the key interlocks for CB4 and CB5 have their bolts extended, thus preventing CB4 or CB5 from being turned ON.
2. Source/input power should be applied to both STS2 inputs.
The touch screen control panel should become active and operate properly when at least one of the inputs is energized is closed.
3. Verify that nominal input voltages are applied to both inputs (Source 1 and Source 2).
The input voltages, selected preferred source, breaker and switch status, and alarms are indicated on the Mimic screen.

Figure 46 STS2 touch screen display

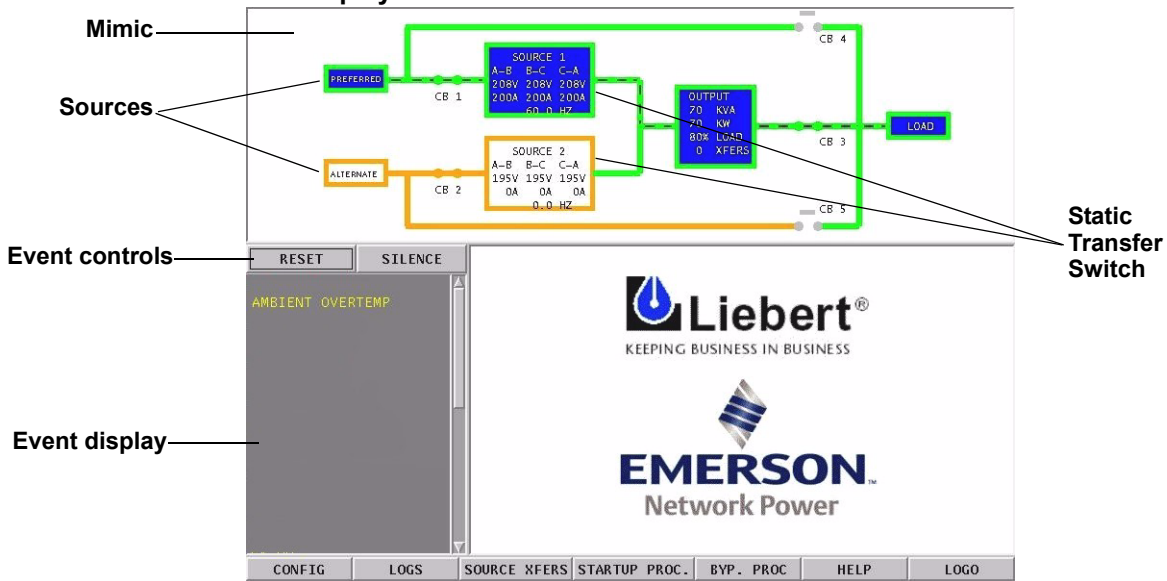

4. Close CB1.
5. Verify that Source 1 voltages are nominal and CB1 breaker status is correctly indicated on the Monitor/Mimic screen.
6. Close CB2.
7. Verify that Source 2 voltages are nominal and CB2 breaker status is correctly indicated on the Mimic screen.
8. Verify that boxes for the preferred source and corresponding static transfer switch are highlighted on the Mimic screen, indicating which side of the Static Transfer Switch is on.
9. Close Output Breaker CB3 (and CB3A in redundant output configurations).
10. Verify CB3, the Output box, and the Load box are highlighted, indicating that CB3 is closed and the Output and Load are energized.



NOTE

For redundant output switch units, CB3 descriptions apply to CB3 and CB3A.

11. Press the RESET button on the touch screen to reset any previous alarms.
12. Verify in the Event Display and the Mimic that there are no active alarms.
If any active alarms are displayed, refer to **11.0 - Alarm and Faults** for a description of the alarms and possible causes. All active alarm conditions should be corrected before proceeding.
13. Turn on the load equipment following the load equipment manufacturer's recommendations.

10.2 Manual Transfer / Preferred Source Selection

The Source Transfer option (Source Xfers) in the touch screen menu allows you to select a preferred source. Transfers are only permitted when the voltage and current are within their proper operating range and the sources are synchronized. The Source Transfer screen indicates the synchronization between the two sources, while the voltage and frequency are displayed on the Mimic. See **Figure 47**. Transfer is inhibited if the deviation exceeds the parameter set in the Source Set Points. See **User Settings on page 89**



NOTE

*If one source will be de-energized for an extended period (hours or days), set the unit to bypass mode for the remaining source. Without using bypass, if a failure occurs in the switch components for remaining source, the STS2 does not have a second source to switch to and the load would not receive power. See **Maintenance Bypass on page 67** for bypass instructions.*

If your system contains the LED front panel instead of the LCD touch screen, refer to **14.2.2 - Manual Transfer / Preferred Source Selection** for instructions on this procedure.

Figure 47 Source transfer screen

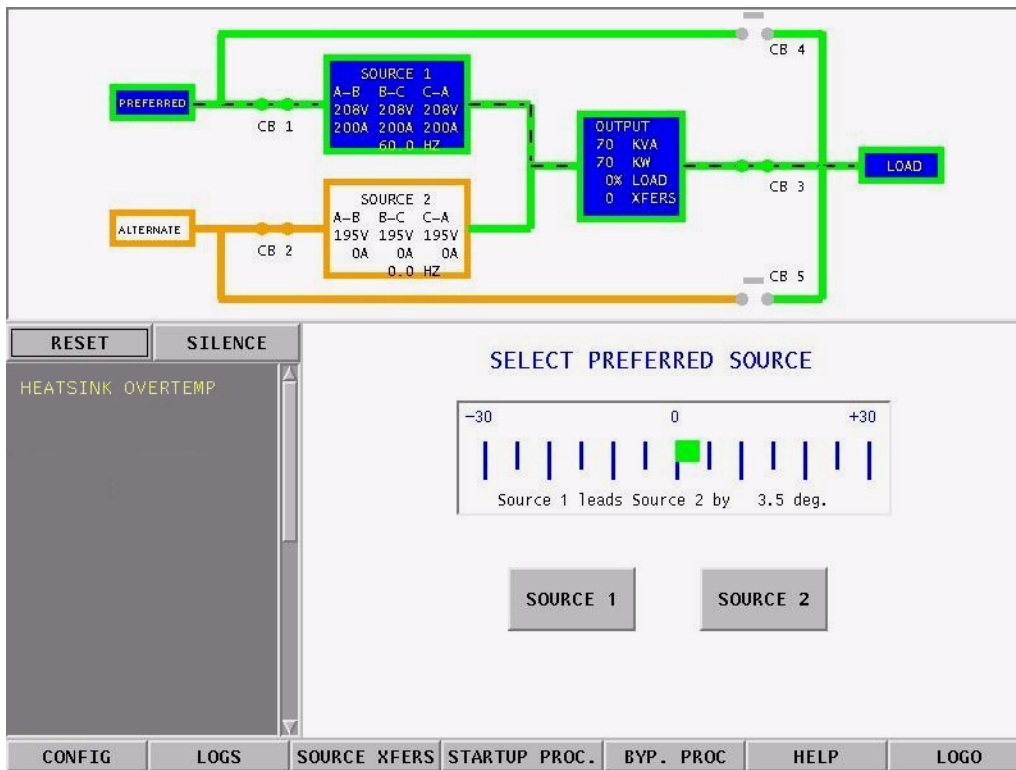

To manually select the preferred source:

1. Verify that the input breakers CB1 and CB2 are closed.
2. Select SOURCE XFERS from the menu bar.
The Select Preferred Source screen is displayed in the Event Display.
3. Check the Mimic to verify that Source 1 and Source 2 input voltages are correct.
4. Select SOURCE 1 or SOURCE 2 as your preferred source.
When conditions are correct, the switch transfers the load to the alternate source by selecting the alternate source as the preferred source.
This source is now monitored as the preferred source throughout the various configurations set up through the touch screen.
5. Verify that the correct source is designated as the preferred source and that the input source changes to the desired source.

The Mimic is updated to indicate the new preferred source. The source is now highlighted with blue and that source is labeled as the preferred source.

If the Transfer Inhibit message is displayed, check for alarm messages on the Active Status window. Correct alarm conditions before attempting a source transfer.

**NOTE**

The preferred source may also be changed via the optional Remote Source Selection option, thereby initiating a transfer remotely.

10.3 Enabling Remote Source Selection

If your system is equipped with the optional Remote Source Selection option, it must be enabled.

If your system includes the Color Graphical Display:

1. Select CONFIG from the menu bar.
2. Select SYSTEM SETTINGS from the Configuration menu.
3. Select SYSTEM OPTIONS from the System Settings menu.
4. Select YES for the REMOTE SOURCE SELECT choice.

If your system contains the LED display or you are configuring the system from the RS-232 port, see **12.1 - Using the RS-232 Port** on page 76 for instructions on using that interface.

10.4 Maintenance Bypass

The STS2 is equipped with two key-interlocked, bypass breakers, CB4 and CB5, to allow manual bypass of the switch electronics for either input source in the event of switch failure or for maintenance of the switch. Refer to the static transfer switch one-line diagram (**Figure 3**). While operating on maintenance bypass, all voltages are removed from the STS2 electronics to facilitate safe repair, without de-energizing the load using a make-before-break switching sequence.

However, the unit can be bypassed using a make-before-break switching sequence only to the same source to which that the switch is connected, as indicated by the highlighted static transfer switch box on the Mimic screen.

In the event of source or switch failure, the unit should be bypassed only to the current input source. For convenience, instructions for the bypass procedure can be displayed on the touch screen by selecting the BYP. PROC option from the menu bar.

The Mimic is used to verify the status of the unit during the bypass procedures. In the unlikely event that the Color Graphical Display is not available, open the front door and look through the slots in the control door. If you can see green LEDs on the gate driver board through that slot, then the unit is connected to the source referenced on the label below that slot. See **Figure 48**.

Figure 48 Gate board viewing slot locations

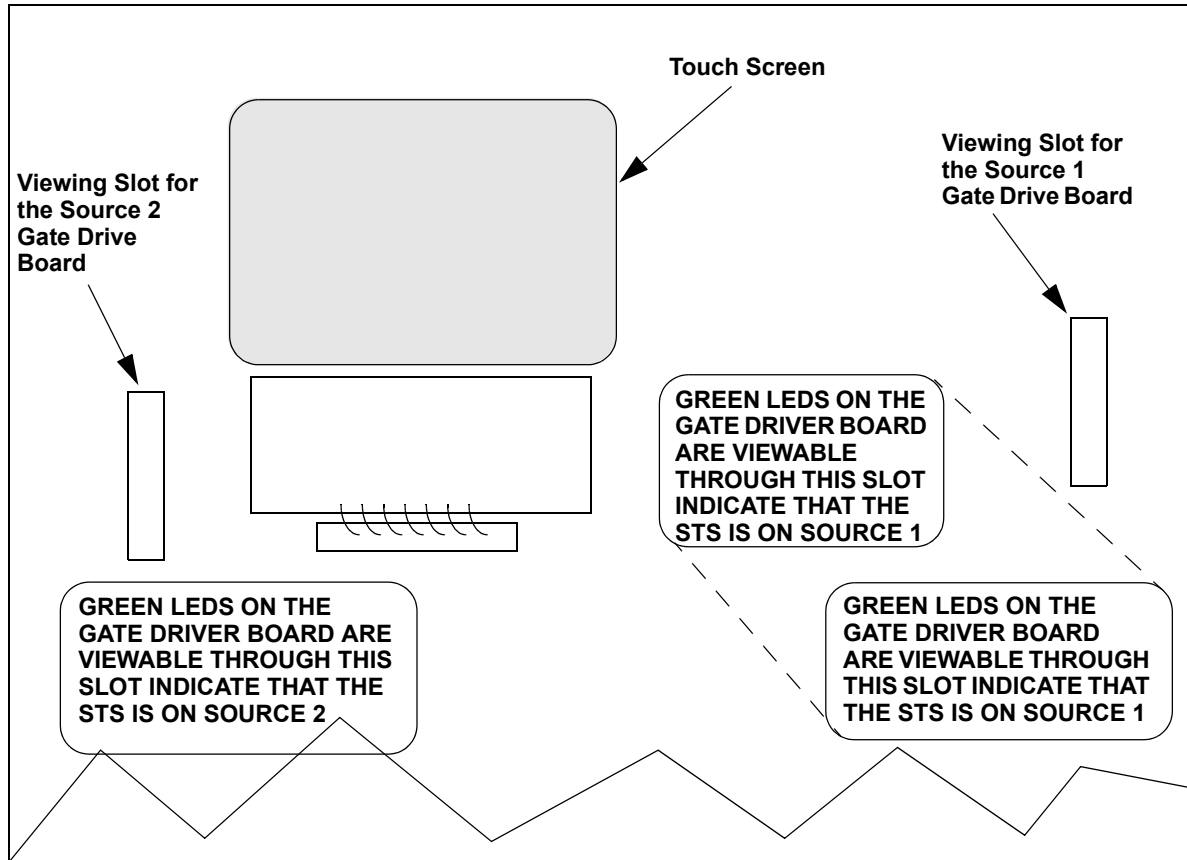

If the Color Graphical Display is not available, you can still use the following bypass procedures, ignore the steps to check the display, and check the LEDs .

If your system contains the LED display, see **14.2.3 - Maintenance Bypass**.

10.4.1 Bypass Procedures for Source 1

To bypass the switch for Source 1:



NOTE

*If you wish to bypass the Source 1 static transfer switch but Source 2 is presently active, you must first transfer to Source 1. See **Manual Transfer / Preferred Source Selection on page 66**.*

1. Verify Source 1 is supplying power via the Mimic.
 - If the Color Graphical Display is not available, check the gate driver board LEDs through the slots in the control panel. See **Figure 48**.
2. Remove interlock key from CB5 and place it in the CB4 interlock.
3. Open the alternate source input breaker CB2.
4. Rotate and remove the interlock key.
5. Insert the key in the CB4 bypass breaker interlock.
6. Rotate interlock keys in CB4 bypass breaker interlock to retract interlock.
7. Close bypass breaker CB4.
8. Verify the breaker status on the Mimic screen.
9. Open source input breaker CB1.
10. Rotate the interlock key and remove it to lockout the breaker.
11. Secure the key, per your site's lockout/tagout procedure.
12. Open output breakers CB3 and CB3A (if supplied) to remove power from static switch.

To return to the normal mode:

1. Remove the key from CB5 and insert it in the CB1 breaker interlock.
2. Rotate key to retract interlock.
3. Close source input breaker CB1.
4. Verify the Source 1 and CB1 breaker status on the Mimic screen.
5. Close output breakers CB3 and CB3A (if supplied).
6. Verify CB3 and CB3A breaker status and STS SOURCE 1 and OUTPUT boxes are highlighted on the Mimic screen.
7. Open bypass breaker CB4.
8. Rotate the keys in CB4 interlock to extend the interlock.
9. Remove the proper key from CB4 interlock and insert it into CB2 breaker interlock.
10. Rotate the key to retract the CB2 breaker interlock.
11. Close source input breaker CB2.
12. Verify the STS SOURCE 2 box and CB2 breaker status on the Mimic screen.
 - If the Color Graphical Display is not available, check the gate driver board LEDs through the slots in the control panel. See **Figure 48**.

10.4.2 Bypass Procedures for Source 2

To bypass the switch for Source 2:



NOTE

*To bypass the Source 2 static transfer switch when Source 1 is presently active, you must first transfer to Source 2. See **Manual Transfer / Preferred Source Selection on page 66**.*

1. Verify Source 2 is supplying power via the Mimic.
 - If the Color Graphical Display is not available, check the gate driver board LEDs through the slots in the control panel. See **Figure 48**.
2. Remove the interlock key from CB4 and place it in CB5 interlock.
3. Open the alternate source input breaker CB1.
4. Rotate and remove the interlock key.
5. Insert the key in the CB5 bypass breaker interlock.
6. Rotate interlock keys in the CB5 bypass breaker interlock to retract the interlock.
7. Close bypass breaker CB5.
8. Verify the breaker status on the Mimic screen.
9. Open source input breaker CB2.
10. Rotate the interlock key and remove it to lockout the breaker.
11. Secure the key, per your site's lockout/tagout procedure.
12. Open output breakers CB3 and CB3A (if supplied) to remove power from static switch.

To return to normal mode:

1. Insert the key in the CB2 breaker interlock.
2. Rotate the key to retract the interlock.
3. Close source input breaker CB2.
4. Verify Source 2 and CB2 breaker status on the Mimic screen.
5. Close output breakers CB3 and CB3A (if supplied).
6. Verify CB3 and CB3A breaker status and STS SOURCE 2 and OUTPUT boxes are highlighted on the Mimic screen.
7. Open bypass breaker CB5.
8. Rotate the keys in CB5 interlock to extend the interlock.
9. Remove the proper key from CB5 interlock and insert it into CB1 breaker interlock.
10. Rotate the key to retract the CB1 breaker interlock.
11. Close source input breaker CB1.
12. Verify the STS SOURCE 1 box and CB1 breaker status on the Mimic screen.
 - If the Color Graphical Display is not available, check the gate driver board LEDs through the slots in the control panel. See **Figure 48**.

10.5 Normal System Shutdown

The STS2 can be shut down from either the static switch mode or the bypass mode.

10.5.1 Shutdown in Static Transfer Switch Mode

When the STS2 is operating on static transfer switch mode (not maintenance bypass mode):

1. Turn off the load equipment per manufacturer's recommendations.
2. Open CB3 to turn off the static switch output.
 - Open CB3A if the static transfer switch has a redundant output configuration.
3. Open the input switches CB1 and CB2.
4. To completely de-energize the unit, turn OFF power to both inputs to the STS2.

10.5.2 Shutdown in Maintenance Bypass Mode

When the Static Transfer Switch is operating on bypass:

1. Turn off the load equipment per manufacturer's recommendations.
2. Open the bypass switch (CB4 or CB5) to turn off the static transfer switch output.
3. To completely de-energize the unit, turn OFF the power to both inputs to the STS2.

11.0 ALARM AND FAULTS

Alarms and faults are events that are triggered when the operation of the static transfer switch falls outside of the defined parameters. These events can also be triggered by: user actions, such as changing configurations, clearing logs, etc.; failed components such as a fan failure, an SCR that is open or closed, etc.; and system status, such as open circuit breakers, load on alternate source, etc. These events can provide a warning or trigger the system to make a change, such as switch sources or the recording of a history log.

The STS2 monitoring system detects and annunciates a comprehensive set of fault and alarm conditions. Faults and alarm messages are can be viewed on the LCD touch screen or via the RS-232 port.

On the LCD touch screen, the events are shown in the Status Display panel in the lower left corner of the touch screen and written to the Event log. You can touch a message to view a definition of an event and a tip for troubleshooting. See **13.0 - STS2 Touch Screen Display** for more information on the touch screen.

If you are monitoring the system through the RS-232 port, see **Table 10 - Terminal Commands** on page 77 for the commands to view event logs, and alarm and fault lists.

Event actions can be triggered by the settings configured from the Event Masks. See **11.1 - Event Mask** for more information.

Faults — A fault indicates that a component of the STS2 has failed or has been damaged. In the Event Display, faults are indicated in *red*.

Alarms — An alarm is an event caused by a significant abnormal system condition. In the Event Display, alarms are indicated in *yellow*. The setpoints for many of the alarms are configurable through the User Settings. Many alarms clear themselves when the condition is resolved. If an alarm event mask is set to *latch*, the alarm messages remain active until the alarm condition has been corrected and the RESET button is pushed. See **11.1 - Event Mask** for more information on latching.

When the system is furnished with an optional internal or external modem and a telephone line is connected to the modem, the system can be programmed to automatically dial out upon occurrence of any of certain designated alarms. The auto-dial feature can be configured for alarms using the Event Mask option in the touch screen. See **Configuring the Modem on page 94** for instructions on for setting up your modem.

11.1 Event Mask

The STS2 gathers, processes and reports faults and alarms, collectively referred to below as *events*. The Event Mask dialog box allows you to set the system's response for specific alarms and faults that are generated.

The following mask types are available for each event:

- *Latch* — If a latch is enabled for the selected event, that event remains active even if the originating event condition clears. A latched event may only be cleared by pushing the RESET button (ALRMRST on the LED units).
- *Dial Out* — If the selected event is triggered, the system automatically calls the specified telephone numbers through the modem. For example, a page could be sent or an event could be sent to an external terminal, via the modem. See **Communication Interfaces on page 76** for more information on configuring communications options.
- *Event Log* — The selected event is date/time stamped and recorded to the Event Log when the event is triggered.
- *Audible* — If the selected event is triggered, an audible beeper or horn is sounded by the STS2. The beeper continues while this event is active or latched, or until the SILENCE button (NOAUD on the LED units) is pushed. This button must be pushed with the ALRMRST button on the LED units.

See **Event Masks on page 88** for instructions on setting the mask type via the touch screen display. See the **12.1.4 - Setting Event Masks with the Terminal** on page 83 for instructions on configuration using the RS-232 port.

11.2 Event and History Logs

The system tracks events through the Events Log and tracks significant events through the History Logs. These logs allow you to quickly spot trends or diagnose problems that the unit may have had. Both logs are written in nonvolatile memory.

The logs can be accessed from the touch screen menu or the RS-232 port. See **13.6.2 - Logs** for more instructions on viewing the logs from the touch screen. See **Table 10 - Terminal Commands** on page 77 for the RS-232 interface commands used to access the logs.

11.2.1 Event Log

The events are tracked in sequence of occurrence. The sequence of occurrence is identified by date, time, and frame number. The last 512 events are stored in a nonvolatile memory and can be viewed from the Event Log.

Event logs wrap, meaning when the log is full, the oldest event is deleted when a new event is written to the log.

The Event Log tracks:

- *#* — the sequence number in which the event occurred since the log was last cleared.
- *Message* — the event that occurred, such as Ambient Over temp., Source 1 Fail, etc.
- *Type* — either a Fault or Alarm. See **11.0 - Alarm and Faults** on page 71 for further details on these events.
- *ID* — the event identifier.
- *Date and Time* — when the event occurred.
- *Faults* — the number of fault events logged.
- *Alarms* — the number of alarm events logged.
- *User Alarms* — the number of alarm events logged that were triggered by user-created alarms, such as those alarms created with the Input Contact Isolator settings.
- *Total* — the sum of all the events currently logged.

11.2.2 History Log

When a designated major alarm occurs, the History Status buffer is frozen, capturing 64 sequential frames before and after the alarm condition. When the History Status buffer is frozen, a History Log is created.

Two History Logs are available to track major alarms. This log includes the triggering event plus the surrounding events, and the system voltages, currents, frequency, power, source selection and breaker positions at the time of the event. The History Log displays the 64 sequential frames, in 4-millisecond intervals, of the Present Status screens surrounding the event.

If you are viewing the log from the touch screen, the Mimic and the Event Display show the data that was present as the alarm was triggered. The data is displayed as frames are played.

The History Log allows you to replay the events leading up to the alarm and the events right after the alarm to see the status of the switch at that time and diagnose the cause of the alarm. The History Log is triggered when certain events are tripped that have the Freeze option enabled.

You can run through the frames sequentially. The sequence of the events is identified by date, time, and frame number. The History Log frames are stored in a nonvolatile memory buffer that is continuously overwritten until a designated fault condition occurs. When the fault occurs to trigger a freeze, the History Log stores the next 23 frames, then freezes until it is reset. The History Log then keeps 40 frames before the fault, the frame where the fault occurred, plus the next 23 frames.

The History Log should not be reset until the fault condition that caused the buffer to freeze is reviewed and investigated by a qualified service technician. After the alarm condition has been corrected, the History Log can be cleared.

The History Log has the following fields:

- *Replay Rate* — indicates how long it takes for the replay to play. Use the UP and DOWN buttons to set the time.
- *Status* — the status of the STS2 at the point of the current frame in the replay. The History log has three statuses: *Frozen*, *Not Frozen* and *Retrieving Data, please stand by*.
- *Critical Event* — The event which triggered this log to be written. The event is indicated in *red* on the bar graph.
- *Frame Number* — the current frame in the replay. A negative number indicates the replay is at a point before the triggering event occurred.

11.3 Alarm Notes

The I-PK on Source 1 and I-PK on Source 2 alarms inhibit automatic transfer due to an overload or load fault. These alarms can be set for either auto or manual alarm reset.

In the auto reset mode, the alarm is reset as soon as the load current and source voltage return to normal, and transfers are no longer inhibited. In manual mode, the alarm remains active and transfers are inhibited until the conditions return to normal and the user manually presses the RESET button (ALRMRST button on LED units). In either case, the cause of the Source 1 or Source 2 I-Peak overload should be investigated and resolved (such as by reducing the overload condition or clearing the output fault) before returning the switch to normal operation.

These events indicate a device failure. The device must be replaced and the system must be restarted for the fault to clear. A shorted SCR automatically trips open a source input switch (CB1 or CB2) to prevent transfers in the event of an SCR failure. The SCR failure must be investigated and repaired before returning the switch to normal operation. Both source input switches must be opened (such as when the unit is placed in maintenance bypass for servicing) before a shorted or open SCR alarm can be reset.

11.4 List of Messages

Table 9 lists available event messages, a definition of the event, and the functions that are activated with the event by default. The functions are indicated as follows:

D — The indicated event initiates the **Auto-Dial** sequence through the optional modem.

A — The indicated event activates the **Audible** alarm.

F — The indicated event triggers a **Freeze** of the History Log.

L — The indicated event **Latches**. A latched alarm remains displayed until the alarm condition has cleared and the RESET (ALRMRST) button has been pressed.

E — By default, all faults and alarms are written to the Event Log. Changing this setting is only available for the LED units and is set through the RS-232 port. See **Setting Event Masks with the Terminal on page 83**

All of these functions, except Freeze, can be reconfigured to trigger for each event, using the Event Mask option. See **11.1 - Event Mask** on page 71. The Freeze function is hard-coded and cannot be changed for a event.

If the front panel of your STS2 contains LEDs and push buttons instead of the touch screen interface, you can view these messages via the RS-232 port. See **12.1.1 - Connecting and Using a Terminal** on page 77 for the commands to view the event messages on a PC terminal.

An LED is used to indicate the presence of any active fault or alarm. Refer to **14.0 - Operating the LED Display STS2** for more information about the LEDs.

Table 9 Event Messages

ID	Alarm Message	Description/Cause	Action
001	S1 SCR SHORT	One or more of the SCRs for Source 1 have shorted and failed.	D, F, A, E
002	S2 SCR SHORT	One or more of the SCRs for Source 2 have shorted and failed.	D, F, A, E
003	S1 SCR OPEN	One or more of the SCRs for Source 1 is open.	D, F, A, E
004	S2 SCR OPEN	One or more of the SCRs for Source 2 is open.	D, F, A, E
005	PRIMARY FAN FAIL	A primary cooling fan has failed and the unit is now being cooled by a secondary fan, which is not monitored.	D, A, E
006	CONTROL MODULE FAIL	Control logic module has failed.	D, A, E
007	PWR SPLY DC A FAIL	Power supply DC bus A has failed.	D, A, E
008	PWR SPLY DC B FAIL	Power supply DC bus B has failed.	D, A, E
009	PWR SPLY S1 AC FAIL	Power supply Source 1 AC has failed.	D, A, E
010	PWR SPLY S2 AC FAIL	Power supply Source 2 AC has failed.	D, A, E
011	PWR SPLY LOGIC FAIL	A power supply module has failed.	D, A, E
012	OUT VOLT SENSE FAIL	The output volt sense module failed	D, A, E
013	S1 VOLT SENSE FAIL	The Source 1 volt sense module failed.	D, A, E
014	S2 VOLT SENSE FAIL	The Source 2 volt sense module failed.	D, A, E
015	S1 SCR SENSE FAIL	The Source 1 SCR sense module failed.	D, A, E
016	S2 SCR SENSE FAIL	The Source 2 SCR sense module failed.	D, A, E
017	S1 CURR SENSE FAIL	The Source 1 SCR current module failed.	D, A, E
018	S2 CURR SENSE FAIL	The Source 2 SCR current module failed.	D, A, E
019	S1 GATE DRIVE FAIL	The Source 1 gate drive module failed.	D, A, E
020	S2 GATE DRIVE FAIL	The Source 2 gate drive module failed.	D, A, E
021	INTERNAL COMM FAIL	Internal CAN communications failed.	D, A, E
022	EXTERNAL COMM FAIL	Options CAN communications failed.	A, E
023	CB1 SHUNT TRIP FAIL	CB1 shunt trip failed.	A, E

Table 9 Event Messages

ID	Alarm Message	Description/Cause	Action
024	CB2 SHUNT TRIP FAIL	CB2 shunt trip failed.	D, A, E
064	HEATSINK OVERTEMP	Heatsink has exceeded the recommended temperature.	A, E
067	S1 UV	Source 1 under voltage, fast detection.	A, E
068	S1 UV (RMS)	Source 1 under voltage, slow detection.	L, A, E
069	S1 OV	Source 1 over voltage	A, E
070	S1 OF/UF	Source 1 over frequency/under frequency	A, E
071	S1 FAIL	Source 1 failure.	A, E
072	S2 UV	Source 2 under voltage, fast detection.	A, E
073	S2 UV (RMS)	Source 2 under voltage, slow detection.	A, E
074	S2 OV	Source 2 over voltage.	A, E
075	S2 OF/UF	Source 2 over frequency/under frequency.	A, E
076	S2 FAIL	Source 2 failure.	A, E
077	S1 OVERCURRENT	Source 1 over current.	A, E
078	S2 OVERCURRENT	Source 2 over current.	A, E
079	S1 I-PEAK	I-PK on Source 1.	A, F, E
080	S2 I-PEAK	I-PK on Source 2.	A, F, E
081	SOURCES OUT OF SYNC	Source 1 and Source 2 are out of synchronization.	A, E
082	LOAD ON ALT SOURCE	The output load is running on the alternate source.	A, E
083	AUTO REXFER INHIBIT	Automatic retransfer is inhibited.	A, E
084	CB1 (S1) OPEN	Source 1, Circuit Breaker 1 is open.	A, E
085	CB2 (S2) OPEN	Source 2, Circuit Breaker 2 is open.	A, E
086	CB4 (S1 BYP) CLOSED	Source 1 on bypass, Circuit Breaker 4 is closed.	A, E
087	CB5 (S2 BYP) CLOSED	Source 2 on bypass, Circuit Breaker 5 is closed.	A, E
088	CB3 (OUTPUT) OPEN	Output circuit breaker (CB3) is open.	A, E
089	CB3A (OUTPUT) OPEN	Output circuit breaker (CB3A) is open.	A, E
090	S1 PHASE ROT ERROR	Source 1 phase rotation error.	A, E
091	S2 PHASE ROT ERROR	Source 2 phase rotation error.	A, E
092	TRANSFER INHIBITED	Transfer inhibited.	A, E
093	OUTPUT UV	Output is under voltage.	D, F, A, E
120 121 122 123 124 125 126 127	INPUT CONTACT #1 INPUT CONTACT #2 INPUT CONTACT #3 INPUT CONTACT #4 INPUT CONTACT #5 INPUT CONTACT #6 INPUT CONTACT #7 INPUT CONTACT #8	Input Contact # x is an optional alarm input. The alarm name can be programmed with an alarm name from the Input Contactor Isolator settings option under the Comm Options. See Configuring the Input Contact Isolator Settings on page 95 . The alarm is sent to Monitor DSP. The LCD logs the alarm with the programmed name. Monitor DSP logs it with the generic name which is how it is reported to the SVT query.	A, E
128	CONFIG MODIFIED	A set point configuration has changed.	A, E
129	PASSWORD CHANGED	The password for touch screen access has been modified and saved.	A, E
130	TIME REPROGRAMMED	The system's time has been reset and saved.	A, E
131	DATE REPROGRAMMED	The system's date has been reset and saved.	A, E
132	EVENT LOG CLEARED	The event log has been erased.	A, E
133	HIST LOGS CLEARED	Both History Logs have been erased.	A, E
134	HIST LOGS FULL	Both History Logs have been written and no more history logs can be written without clearing one of the logs.	A, E

12.0 COMMUNICATION INTERFACES

The STS2 monitoring system offers several choices for communications.

The RS-232 terminal port is standard on all units. The port is located inside the front door, to the left of the touch screen/LED front panel mounting as shown in **Figure 29**. This port is primarily used as an alternate user interface to configure, control, and diagnose the system, especially for systems that do not include the HMI touch screen. Commands for the RS-232 port are shown in **Table 10**.

Several other communications options are also available. Those options are located a Communications compartment to the right of the touch screen/LED front panel and are accessible when the front panel door is open. See **Figures 21** and **22** for the location of the communications options.

Connections to the communication ports are made by wiring to terminal boards located in the Communications compartment. The communications options listed below reference the control wiring drawing for each option.

- Internal modem (optional) — the connection to this modem is through a standard RJ-11 port. This port automatically dials the programmed telephone number when a designated alarm occurs. Automatic dial attempts are made to the first phone number at periodic intervals for 30 minutes. After that time, auto dial attempts are made to the second phone number at periodic intervals for the next 30 minutes. The process is repeated until a successful connection is made. Upon successful connection, the system transmits the status information and then hangs up. System status and history information can be requested and date and time can be changed through the modem. The modem commands are shown in **Table 10** on page 77. See **Figure 27** for more information on the internal modem.

- Network Interface Card (NIC) (optional) — the NIC provides connectivity to any TCP/IP-based Ethernet network to allow the device to communicate with network management systems (NMS) via SNMP. Events can be transmitted to the NMS to provide remote status monitoring, plus fault and alarm detection. The NIC includes an RJ-45 port for an Ethernet connection, via Category 5 cable.

The NIC can also integrate the system with an existing Building Management System (BMS) or out-of-band monitoring, using Modbus, a standard multi-drop protocol. The NIC has redundant communication paths that make it possible to connect to a BMS using Modbus while simultaneously communicate to a NMS through SNMP

See **Figure 28** for more information on the NIC. If you have questions about the NIC, refer to the *OpenComms Network Interface Card Installation and Users Guide*.

- Input Contact Isolator (ICI) Board (optional) — provides an interface for up to eight user inputs. External messages and alarms can be routed to the unit, via the ICI.

See **Configuring the Input Contact Isolator Settings on page 95** for instructions on configuring the connections. See **Figure 25** for wiring details.

- Programmable Relay Board (PRB) (optional) — up to two PRBs can be installed in the STS2 to route STS2 events to external devices.

See **Configuring the Programmable Relay Board Settings on page 97** for default settings and instructions for reconfiguring the relays. See **Figure 24** for wiring details.

- Comms Board (optional) — includes a terminal block to provide a DTE connection to an external modem. This board also provides a direct connection to a SiteScan terminal, via an RS-422. SiteLink-12 or SiteLink-4 is required for SiteScan to communicate with the STS2. See **Figure 26** for wiring details.

Data link requirements are Full Duplex Asynchronous RS-232 format.

Communications options are also discussed in **6.0 - Options**.

12.1 Using the RS-232 Port

The RS-232 port is configured with a baud rate of 9600 with 8 Data Bits, 1 Stop Bit, No Parity, and no hardware handshaking.

12.1.1 Connecting and Using a Terminal

An RS-232 connection can be used to connect the STS2 to either a terminal or a PC running terminal emulation software. If you are unsure of the cable pin out, see **15.2.10 - Terminal Port Connections**.

1. Connect the terminal to the STS2 by plugging the cable from the terminal into the RS-232 port. This connection can be made at any time.
2. After making the connection, verify the communications link by pressing <ENTER> on the terminal keyboard.

The interface communications system responds as indicated below:

```
Repeating command -->
Illegal command!
<?> or <HELP?> displays the RS-232 command set
<?> <command> or <HELP?> <command> displays specific help for the command
SVTP-Control >
```

The **SVTP-Control >** prompt indicates that RS-232 communications are established.

- If you receive no response or prompt, verify that the connector is properly plugged into the port and the PC or terminal serial interface is working properly.

3. Enter the desired commands, as listed in **Table 10**.

For additional help type <?> <command> or <HELP?> <command>

Refer to the corresponding menu options in the **13.0 - STS2 Touch Screen Display** for more details about the commands.

Some terminal commands require a password to function. Use the PWD command and a valid password to gain access.

Table 10 Terminal Commands

Keys	Function
?	Displays this help menu or specific help with a command
AA?	Displays active alarms
AF?	Displays active faults
CEL	Clears the event log
CHL	Clears the history logs
DATE?	Displays current system date
DATE	Sets system date
EL?	Displays the entire event log
HELP?	Displays this help menu or specific help with a command
HLn?	Displays the history log #n, if frozen
LOGOUT	Logs user out of unprotected mode
PS?	Displays the preferred source
PS n	Sets the preferred source to #n
PWD	Allows users to access protected commands
QUIT	Modem only. Ends the session and hangs up the modem.
SH	Silences the horn
SPT?	Displays all current setpoints
SPTx	Displays current setpoints for group x. See 12.1.2 - Configuring the STS2 via the Terminal for a description of groups.
SR?	Displays status reports
TIME?	Displays current system time
TIME	Sets system time
UPMDR?	Displays metering data
VER?	Displays firmware versions

12.1.2 Configuring the STS2 via the Terminal

The SPT command is used to configure the systems setpoints. The SVT syntax for the setpoints consists for four parameters:

SPT [*group*] [*item*] [*value*]

where the parameters are:

- SPT — is the terminal command that is used to configure setpoints.
- *group* — the group under the setpoint command which contains the desired settings.
- *item* — the item number within the selected group.
- *value* — the desired value for this item.

Only the specific options words listed in this section use a hexadecimal value. Other settings, depending on what they are, use other input types. For example, System ID uses a text string, nominal voltages and currents use standard numeric integers, and modem baud rate uses an enumeration where 0 = 2400, 1 = 9600, & 2 = 19200 bps.



NOTE

Spaces are placed between each parameter, but not between characters or numbers in a parameter. Using an underline here to represent a space, an example of a the syntax is: SPT_2_6_0081. 0081 is the value parameter.

This section provides instructions for setting these parameters, with an example of building an SPT command for System and User settings.

Groups Parameter

The setpoints are grouped for ease of configuration. For example, Event Masks are group 4 and System Settings are group 2. The numbers shown below are entered for the group parameter. For example, start of a System Settings command is *SPT 2*.

The group parameters are:

- 1 = System Ratings
- 2 = System Settings
- 3 = User Settings
- 4 = Event Mask Settings

For example, the start of a System Settings command is *SPT 2*, where SPT is the system setpoints command and 2 is the group parameter for System Settings.

See **12.1.4 - Setting Event Masks with the Terminal** on page 83 for instructions on configuring Event Mask parameters.

Item Parameter

Each setting within the group is indexed by an item number as shown below in **Table 12**. These item numbers are also displayed on the terminal when you list the configuration setting for a particular group

Continuing with the example, to configure an Options_1 setting under System Settings, the command would begin with *SPT 2 6*

where 6 is the value Options_1. Note the space between each parameter.

Value Parameter

Item settings, depending on what they are, use various value types.

Table 11 provides a list of the possible value types and their description.

Table 11 Value types

Type	Definition
Numeric	An integer numeric value in the units indicated by the item name. For example, a System Voltage Rating of <i>480</i> would indicate <i>480 volts</i> .
Scaled	Similar to the Numeric, this value type is an integer that has been scaled, usually to remove decimal points that would normally appear within the value. In this case, a value of <i>2.5</i> may actually be input as simply <i>25</i> . For all Scaled types, the scaling appears in Table 12 .
String	Certain settings are represented by alphanumeric character strings, such as setting the System Model Number to <i>STS2</i> .
Enumeration	This type uses an indexed list to represent possible choices. One example is the Modem Baud Rate which uses a value of <i>0</i> to select 2400 bps, <i>1</i> for 9600 bps, and <i>2</i> for 19200 bps.
Bit-packed	This type of value uses a <i>hexadecimal binary word</i> , where each of the sixteen <i>bits</i> in the word has the value of <i>1 (True)</i> or <i>0 (False)</i> . Although somewhat difficult to use, it packs a large amount of data within a single entry. A detailed description of this type appears in section 12.1.3 - Setting Bitpacked Options with the Terminal on page 81.
Event Masks	This type is a specially formatted and is used to customize the behavior of each fault and alarm in the system. See 12.1.4 - Setting Event Masks with the Terminal on page 83 for instructions on configuring Event Mask parameters.

Table 12 shows the various groups, the settings contained within, and the type of value it requires.

Table 12 Group settings and values

Group	Item:	Description	Value Type	Value Notes
Group 1: System Ratings	1	Input Volts (PDU)	Integer	Set per system spec.
	2	Volts	Integer	Set per system spec.
	3	Current	Integer	Set per system spec.
	4	Frequency	Scaled	Desired freq. x 10 (<i>600</i> = 60 Hz)
Group 2: System Settings	1	Language	Enumeration	[Not supported at this time]
	2	System Model Number	String	14 Character max.
	3	System ID Number	String	8 Character max.
	4	System Tag Number	String	8 Character max.
	5	System Order Number	String	8 Character max.
	6	Options_1	Bitpacked	14 Character max.
	7	Autodial Primary Line	String	20 Character max.
	8	Autodial Secondary Line	String	20 Character max.
	9	Autodial Pager Number	String	20 Character max.
	10	Autodial Pager PIN	String	10 Character max.
Group 2 (cont.)	11	Modem Init String	String	20 Character max.
	12	Modem Baud Rate	Enumeration	0 = 2400, 1 = 9600, & 2 = 19200 bps
	13	Modem LGS Check - Day	Bitpacked	
	14	Modem LGS Check - Time	Bitpacked	
	15	Comms Options 1	Bitpacked	See section 12.1.3 .
	16	Comms Options 2	Bitpacked	See section 12.1.3 .

Table 12 Group settings and values (continued)

Group	Item:	Description	Value Type	Value Notes
Group 3: User Settings	1	SRC1 Fast Undervoltage Setpoint	Integer	In % of nominal below nominal
	2	SRC1 Slow Undervoltage Setpoint	Integer	In % of nominal below nominal
	3	SRC1 Slow Undervoltage Detect Delay	Integer	In number of lines cycles
	4	SRC1 Overvoltage Setpoint	Integer	In % of nominal above nominal
	5	SRC1 Overvoltage Detect Delay	Integer	In 1/4 lines cycles
	6	SRC1 I peak Transfer Setpoint	Integer	x 10
	7	SRC2 Fast Undervoltage Setpoint	Integer	In % of nominal below nominal
	8	SRC2 Slow Undervoltage Setpoint	Integer	In % of nominal below nominal
	9	SRC2 Slow Undervoltage Detect Delay	Integer	In number of lines cycles
	10	SRC2 Overvoltage Setpoint	Integer	In % of nominal above nominal
	11	SRC2 Overvoltage Detect Delay	Integer	In 1/4 lines cycles
	12	SRC2 I peak Transfer Setpoint	Integer	x 10
	13	Max. Transfer Phase Angle	Integer	In degrees
	14	Output Frequency Deviation	Integer	Freq. in Hz x 10
	15	ReTransfer Delay Time	Integer	In seconds
	16	Horn Volume	Integer	Range: 1-10
	17	Critical Option Enabling	Bitpacked	See section 12.1.3.
	18	Non-Critical Option Enabling	Bitpacked	See section 12.1.3.
Group 4: Event Mask Settings	1 to 63	Event Mask settings for faults	Event Mask	See section 12.1.4.
	64 to 143	Event Mask settings for alarms	Event Mask	See section 12.1.4.

12.1.3 Setting Bitpacked Options with the Terminal

Five sets of *options* and *features* settings are available through the terminal to control the system operation.

Under System Settings for the SPT command, these items denote which options are INSTALLED:

- 6 — Options_1
- 14 — Comms Options 1
- 15 — Comms Options 2

Under User Settings, for the SPT command, these items denote which features are ENABLED:

- 17 — Critical Option Enabling
- 18 — Non-Critical Option Enabling

The value parameter settings are in the form of a *bit-packed word* (in hexadecimal notation). In other words, each bit indicates a particular setting for the option or feature. The bit assignments for the options and features are as follows:

Options_1

- bit0 — HasDualOutputBreaker
- bit1 — HasPDU
- bit2 — Has4PoleTransferSwitch
- bit3 — HasShuntTrip
- bit4 — HasWyeOutputXfmr
- bit5 — HasExternalPrecisionTimeSource
- bit6 — HasSFA
- bit7 — HasRemoteSourceSelect
- bit8 through bit15 — not used (set to 0)

Comms Options 1

- bit0 — HasIntModem
- bit1 — HasExtModem
- bit2 — HasNIC
- bit3 — not used (set to 0)
- bit4 — HasSiteScan
- bit5 — not used (set to 0)
- bit6 — not used (set to 0)
- bit7 — HasOpenCommsDigitalInputBrd
- bit8 — HasOpenCommsDigitalOutputBrd_1
- bit9 — HasOpenCommsDigitalOutputBrd_2
- bit10 — HasRemoteStatusPanelBrd_1
- bit11 — not used (set to 0)
- bit12 — not used (set to 0)
- bit13 — not used (set to 0)
- bit14 — EnableDialIn
- bit15 — EnableDialOut

Comms Options 2

- bit0 — EnablePager
- bit1 — EnableOCDINormallyClosed
- bit2-3 — OCDO1Assignment (0=User Defined, 1=Standard Set or 2=AS400)
- bit4-5 — OCDO2Assignment (0=User Defined, 1=Standard Set or 2=AS400)
- bit6 through bit15 — not used (set to 0)

Critical Option Enabling

- bit0—EnableManual_IPeakReset
- bit1—EnableAutoRestart
- bit2 through bit15 - not used (set to 0)

Non-Critical Option Enab

- bit0 — EnableAutoReXfer
- bit1 through bit15 — not used (set to 0)

The bits are set in reverse order, from bit 15 on the left to bit 0 (zero) on the right. The bits are grouped in four sets of four bits each, as such:

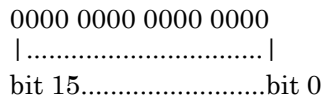

Since each bit represents a setting, a bit can be enabled or disabled:

- **1** = installed option or enabled feature
– or –
- **0** = option not installed or feature not enabled

Enabling or disabling the bits in each group creates a binary value for that group. For example, if the fourth bit in a group is set to 1, the group's binary value is 0001.

Each group is translated into a hexadecimal equivalent. The group with the value of 0001 has a hex equivalent of 1.

You can use this table to help with the conversion:

Table 13 Binary-Hexadecimal Conversions

Binary value	Hex Equivalent	Binary value	Hex Equivalent
0000	0	A	1010
0001	1	B	1011
0010	2	C	1100
0011	3	D	1101
0100	4	E	1110
0101	5	F	1111
0110	6		
0111	7		
1000	8		
1001	9		

The hex value for each group is entered in the command as four digits.

To summarize the procedure:

1. Set each bit position.
2. Convert the binary value each group into its hex equivalent.
3. Enter the hex values for each group, in order, into the command for the value parameter.

The following example explains how the conversion is completed.

Putting the Terminal Command Together

For example, a unit only has the Remote Source Selection and Dual-Output Breaker options installed.

Checking the bits list under **Options_1 on page 81**, bits 7 and 0 each must be set to 1 to indicate that these options are installed.

The bit setting is as follows, starting with bit 15 on the left and going down to bit 0:

```
0000 0000 1000 0001
```

With the bits combined in groups of four, the binary settings can be translated into hexadecimal values.

The first two groups in the sample equal zero (0). In the third group, 1000 in binary translates to 8 in hex. In the fourth group, 0001 in binary translates to 1 in hex.

In hex this equates to (digits in the value parameter cannot have spaces between them):

```
0081
```

So your command to indicate that the Remote Source Selection and the Dual-Output Breaker are installed would be:

```
SPT 2 6 0081
```

12.1.4 Setting Event Masks with the Terminal

The event masks can be customized via a terminal. The command `SPT4?<ENTER>` displays all faults and alarms, along with their associated event masks. A plus sign (+) means that particular event mask is enabled, while a minus sign (-) means that mask is disabled.

Refer to **11.1 - Event Mask** on page 71 for more information on event masks and their associated flags.

Unlike the System and User Settings, mask values are set by designated letters, not hex values. However, as with other RS-232 interface settings, four parameters are passed. See **12.1.2 - Configuring the STS2 via the Terminal** on page 78 for more details about the parameters.

The syntax for configuring event masks is:

```
SPT 4 ID ±D±L±S±E±A
```

- SPT — is the terminal command used to configure setpoints.
- 4 — setting (group parameter) for event masks, under System Settings.
- ID — event ID. The ID is the item parameter for this command. The ID numbers for each event are listed with the events in **Table 9** on page 74.
- D,L,S,E,A — the event masks: *Dial*, *Latch*, *Summary*, *Event log*, and *Audible*. The masks are the value parameter for the command.

Each mask type **must** be preceded by a plus sign (+) to enable it, or a minus sign (-) to disable it.



NOTE

NO spaces are placed between each mask listed above.

Only the mask that is passed (enabled) is applied when the event occurs.

Note that the Summary and Event Log event masks are only configurable for the LED units.

To set the event masks for a particular event:

1. Enter the command. Examples and descriptions are provided below.
2. Press ENTER.

After the new settings are entered, the new results for that event ID are displayed.

Examples of Event Mask Settings

- To latch event #001, S1 SCR SHORT, use SPT 4 1 +L.
- To disable event #128, CONFIG MODIFIED, from sounding the horn, use SPT 4 100 -A.
- To enable event #012, OUT VOLT SENSE FAIL, to Dial and go into the Event Log, use SPT 4 12 +D+E.
- To disable all masks for event #120, INPUT CONTACT #1, use SPT 4 120 -D-L-S-E-A.

To breakdown this syntax for the last example:

- SPT — SVT command
- 4 — group parameter, identifying System Setting group under which the Event Mask settings reside.
- 120 — item parameter. In this command, that is the event ID.
- -D-L-S-E-A — value parameter. In this case, the minus sign (-)disables all masks for the INPUT CONTACT #1 event.

13.0 STS2 TOUCH SCREEN DISPLAY

The STS2 can be configured with a Color Graphical LCD touch screen display that allows you to quickly check the status of the unit and identify problems.

A touch screen LCD is available through the front of the STS2. This screen provides a graphical (Mimic) display of the switch's operation, plus system information including system parameters, alarms and faults.

The LCD provides a color, back-lit touch screen as a user interface. In addition to the Mimic and the system parameters, the screen provides a series of menus to allow you to configure the STS2, including the control of the preferred source, auto/manual retransfer selection, alarm notification, and other system setpoints. The touch screen also provides buttons to reset alarms and turn off audible alarms, such as a horn.

13.1 Display Overview

The STS2 Color Graphical Display provides three areas of information, plus buttons and a series of menu choices.

The Color Graphical Display contains the following features:

- **Mimic** — a graphical diagram of the status of the unit.
- **Event controls** — allow you to reset alarms and turn off audible alarms.
- **Event Display** — displays any active alarm or fault condition, in real-time.
- **Menus** — provide choices and configuration settings in dialog boxes or information in the display panel.
- **Display panel** — provides additional information, depending on the menu choice that was last selected. This information includes event help text, and startup and bypass procedures.

Figure 49 STS2 touch screen display

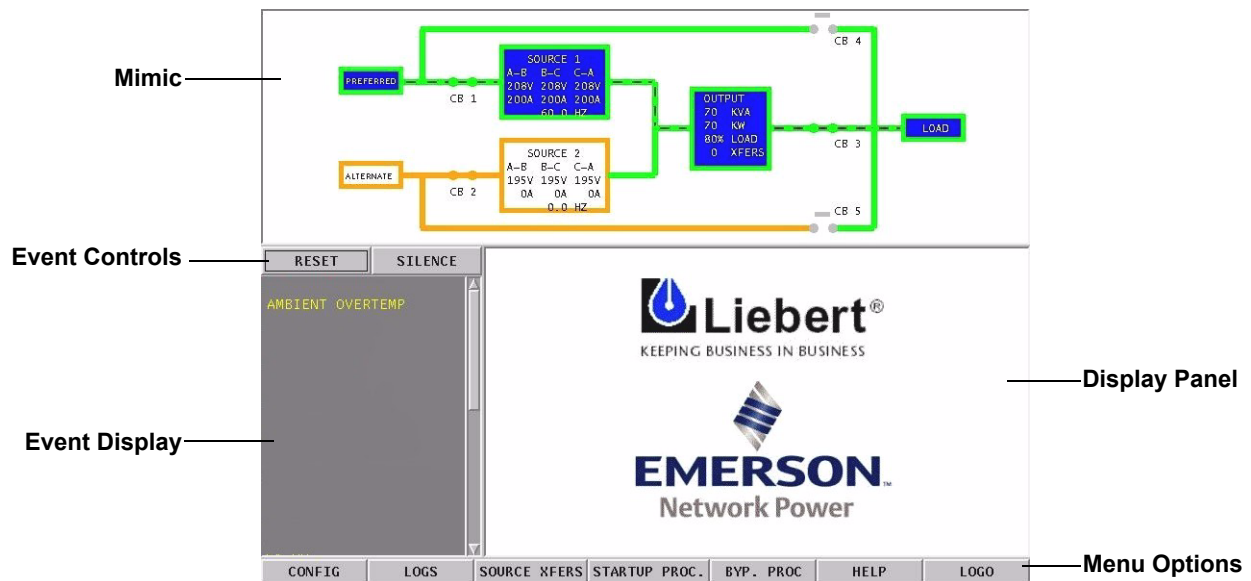

13.2 Menu Overview

The touch screen menu provides access to configuration settings and more device information.

The CONFIG (Configuration) and LOGS menus provide multiple choices through pop-up menus. The SOURCE XFER menu selection allows you to select the preferred source. The other menu choices provide information in the display panel. The menu choices are discussed later in this manual.

All programmable functions are preset at the factory to default settings. These settings enable the unit to be brought up without the need to enter all selectable parameters. The menus allow the settings to be customized.

Figure 50 Menus

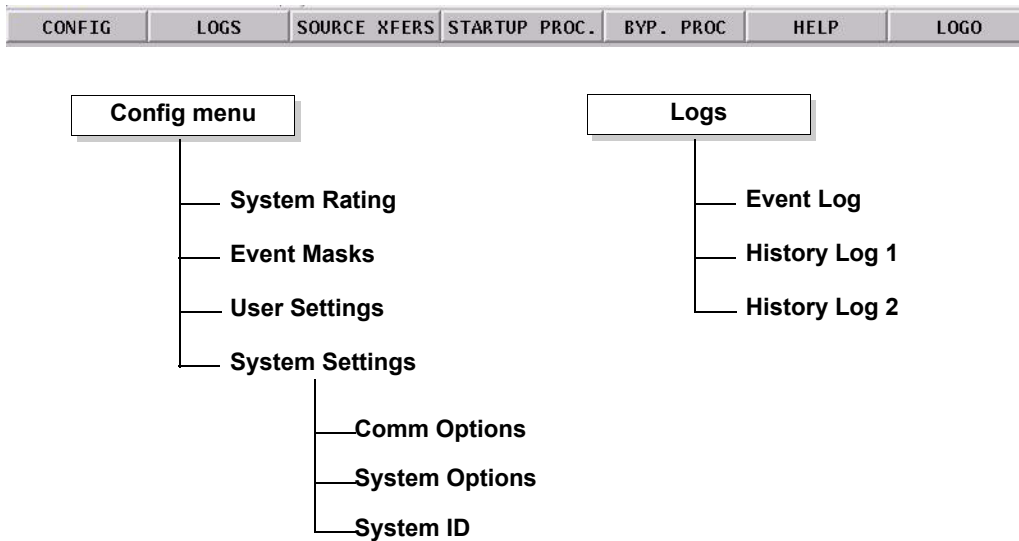

NOTE

Some menu choices display a keyboard or keypad on the touch screen. Enter data on the touch screen.

Click OK to save the data that you have entered.

Use the back arrow button (<-) to delete unwanted characters. This button functions like a backspace key on a keyboard.

Figure 51 Keyboard and keypad displays

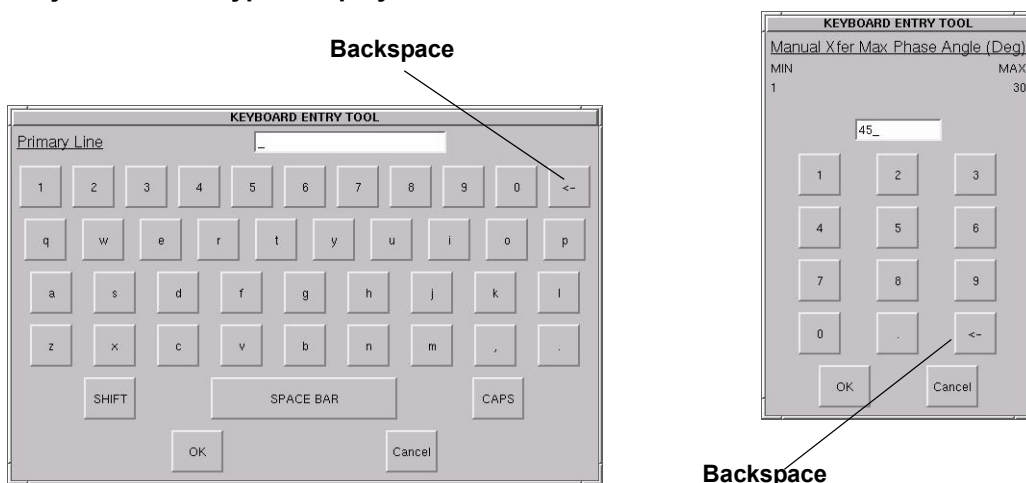

13.2.1 Security

Because the STS2 Color Graphical Display provides access to various configuration and monitoring choices, a password or key lockout switch may be used to protect access to certain changes, including:

- Change configuration settings.
- Clear logs.
- Make a source transfer.
- Reset an alarm.

Without entering the password or enabling changes with the key lockout switch, you still can:

- View the display, including the mimic, status and event help.
- View logs.
- View the startup and bypass procedures.
- Use the SILENCE button to turn off the audible alarm.

Using the Optional Key Lockout Switch

An optional key lockout switch for the STS2 enables or disables the ability to make changes on the STS2. The key lockout switch is mounted on the front door. See **Figures 8 through 10** for location of the key lockout switch.

- To disable the changes, turn the key to the top of the switch, toward the closed padlock.
- To enable changes turn the key to the horizontal position, toward the open padlock.

Figure 52 Key lockout switch.

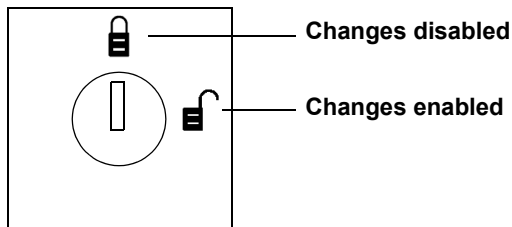

Using the Password

If the unit is not equipped with a keylock, a password is required when you attempt to:

- Save changes in the CONFIG menu choices.
- Transfer sources.
- Reset active alarms.
- Clear logs.

When a password is requested, a keyboard is displayed on the touch screen. After you enter the password, select OK.

The password is case-sensitive. Password access times out after ten (10) minutes, and must be reentered to save changes. The time-out period cannot be changed.

To set or reset the password:

1. Select SYSTEM SETTINGS from the CONFIG menu.
2. Select SYSTEM ID form the SYSTEM SETTINGS menu.
3. Click PASSWORD.
A keyboard is displayed.
4. Enter a password.
The password must be four (4) alpha-numeric characters and is case sensitive.
5. Click OK.

13.3 Mimic Display

The Mimic display provides a color diagram of the operation of the STS2. This display imitates the power flow through the static transfer switch and indicates source status, breaker status, switch status, source voltage and current readings, output power measurements, and active alarm messages. See **Figure 49** on page 85.

13.4 Event Controls

The STS 2 detects events when certain thresholds are passed or certain problems occur. The alarm controls allow you to acknowledge the existence of these events.

- **RESET** — All latched events whose conditions have cleared are removed from the Event Display. Faults and alarms that remain active, or are not recoverable, are not affected when this button is selected. This button is also used to perform manual I-Peak resets and manual retransfers.
- **SILENCE** — turns off the audible alarm (horn or beeper) without resetting the triggering event. This setting does not permanently turn off the horn. The alarm sounds again when the next event with an audible alarm setting is triggered.

Active events are shown in the Event Display, whereas cleared events can be reviewed via the Event Log.

13.5 Event Display

The Event Display lists the condition of the STS2 in real-time. Both nominal system parameters and alarm messages are displayed in the Event Display. You can touch any message in the Event Display to display more information in the Display Panel to the left. The selected status is displayed in bold type.

13.6 Menu bar

As previously mentioned, the menu bar provides both configuration choices and information. The choices under the Config and Log menus access additional dialog boxes, while the other menu choices only show information in the display panel.

13.6.1 Configuration Menu



When you select the CONFIG (Configuration) menu choice, a pop-up menu is displayed with four choices.

- *System Ratings* — used to configure frequency, voltage and currents settings for the STS2.
- *Event Mask* — allows you to configure system's response for events.
- *User Settings* — allows you to configure operations for the STS2.
- *System Settings* — accesses another pop-up menu to configure communication and system choices and the system ID.

Each of these choices accesses a separate dialog box.

System Ratings

The System Ratings menu is used to set the nominal line frequency, nominal voltage and nominal current at which the system operates when it is installed. These settings are configured when the system is initialized at the factory or under maintenance and should not be changed by the user.

Event Masks

The STS2 gathers, processes and reports faults and alarms, collectively referred to below as *events*. The Event Mask dialog box allows you to set the system's response for specific alarms and faults that are generated. See **11.0 - Alarm and Faults** for more information on events and **11.1 - Event Mask** for the definitions of the Event Mask types.

To set the event masks:

1. Access the Event Mask dialog box:
 - a. Select CONFIG.
 - b. Select EVENT MASK from the pop-up menu.
The Event Mask dialog box is displayed. See **Figure 53**.
2. Select the mask settings for each fault and alarm.
 - a. Select YES to enable the setting,
– or –
 - b. Select NO to disable the setting.
3. Select SAVE to keep the settings.

Figure 53 Event mask dialog box

Alarm / Fault Name	Latch	Dial Out	Event Log	Audible
FAULTS				
CB1 SHUNT TRIP FAIL	NO	NO	NO	NO
CB2 SHUNT TRIP FAIL	NO	NO	NO	NO
CB6 NEUT OPEN	NO	NO	NO	NO
CONTACTOR NEUT FAIL	NO	NO	NO	NO

Save Cancel

User Settings

The User Settings choice allows you to adjust the user-accessible switch settings. Access is limited to qualified personnel via system security.

To access the User Settings dialog box:

1. Select CONFIG.
2. Select USER SETTINGS from the pop-up menu.

The User Settings dialog box is displayed. See **Figure 54**. The top six buttons access a series of secondary dialog boxes to configure the various settings.

Figure 54 User settings dialog box

Source Set Points

The Source 1/2 Set Points allows you to configure trigger points for each input source (1 or 2) for the STS2 via a keypad dialog or HI/LO dialog box. The source numbers do not designate the source as the preferred or alternate source. The numbers simply identify the input source. See **10.2 - Manual Transfer / Preferred Source Selection** to set the preferred source.

The Set Points are based on values in relation to the nominal voltage required for the STS2. UV refers to *under voltage*, meaning the amount of voltage below the nominal voltage. OV refers to *over voltage*, or the amount of voltage over the nominal voltage.

- *Fast UV Setting (%)* — if the voltage drops below this set percentage of the nominal voltage, the STS2 transfers from the current source to the opposite source.
- *Slow UV Setting (%)* — if the voltage remains this set percentage below the nominal voltage for the period of the slow detection delay, the STS2 transfers from the current source to the opposite source.
- *Slow UV detection delay* — the number of cycles that the source must remain below the Slow UV Setting before the STS2 transfers.
- *OV Setting (%)* — if the voltage exceeds this set percentage of the nominal voltage for the period of the OV detection delay, the STS2 transfers from the current source to the opposite source.
- *OV Detection Delay* — the number of cycles that the source must remain above the OV Setting before the STS2 transfers sources.
- *I-PK Xfer Lockout* — if current from the source exceeds this threshold, the STS2 disables source transfers, and has to be reset either manually or automatically. The type of reset is configured under the User Settings.

To configure the set points for each source:

1. Select SOURCE 1/2 SET POINTS from the User Settings dialog box.
The Source 1/2 Set Points dialog is displayed.

Figure 55 Source setpoints

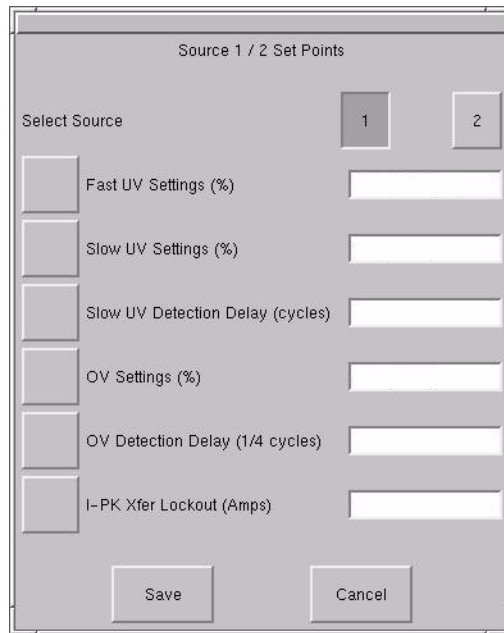

2. Select **1** to configure the settings for Source 1.
3. Configure the settings using the keypad or dialog box that is displayed when you touch a button.

Table 14 Set Point Parameters

Button	Range	Default	Comments
Fast UV Setting (%)	-10 to -30% of Nominal voltage rating	-20%	Set in increments of 1%.
Slow UV Setting (%)	-5 to -20%	-10%	Set in increments of 1%.
Slow UV detection delay	1-60 cycles	5 cycles	Units: Line Cycle
OV Setting (%)	+5% to +20%	+10%	Set in increments of 1%.
OV Detection Delay	1-255 cycles	3 cycles	Units: 1/4 Line Cycle
I-PK Xfer Lockout	0 – 3.0 multiplied by the unit current rating.	2.5 * Unit Current Rating	I-peak xfer lockout detection point. Units: Amps RMS. Select the HI or LO buttons to configure your setting.

4. Select **2** for Source 2.
5. Configure the settings, as described in step **3**.
6. Select SAVE to keep the settings for both sources.
The Set Points dialog is closed and the User Settings dialog is displayed.
7. Select MANUAL MAX XFER PHASE ANGLE.
A keypad is displayed.
This setting configures the maximum allowed phase difference between the sources and applies to all manual transfers as well as any auto retransfer.
 - a. Configure this setting with a range of +/- 1-30 degrees.
The default setting is +/-15 degrees and the resolution is 1 deg.
 - b. Select OK to save the setting.
The setting is now displayed in the adjacent field in the User Settings dialog box.

8. Select FREQUENCY TRIP POINT.

A keypad is displayed.

This choice verifies that the source is running at the proper frequency. This choice sets the frequency deviation in the frequency that triggers the frequency trip point alarm. The frequency deviation setting is the allowable frequency variation from nominal (60.0 or 50.0 Hz) before activating the frequency deviation alarm. The frequency setting applies to both input sources.

- a. Configure this setting with a range of 0.1 – 3.0 Hz

The default setting is 0.5 and the resolution is 0.1.

- b. Select OK to save the setting.

9. Select RETRANSFER DELAY.

A keypad is displayed.

With the secondary source being used, this setting sets the length of time the switch waits until attempting to transfer back to the preferred source.

- a. Configure this setting with a range of 1 to 60 seconds.

The default setting is three (3) seconds and the resolution is 1 second.

- b. Select OK to save the setting.

The setting is now displayed in the adjacent field in the User Settings dialog box.

10. Select AUDIO LEVEL.

A dialog box is displayed with HI and LO settings.

This choice sets the loudness of the horn or beeper that is sounded for audible alarms.

- a. Configure this setting with a range of 1–10 (ten).

The default setting is 5. The settings have an increment of 1 (one).

- b. Select OK to save the setting.

The setting is now displayed in the adjacent field in the User Settings dialog box.

You can select TEST to briefly sound the alarm to judge its volume.

11. Select DISPLAY BRIGHTNESS.

A dialog box is displayed with HI and LO settings.

This choice sets the brightness for the touch screen.

- a. Configure the Contrast and Brightness settings with a range of 1 – 10 (ten).

- b. Select OK to save the settings.

12. Set the AUTO REXFER ENABLE choice.

The auto retransfer enable setting determines whether the switch automatically returns the preferred source after that source is restored.

- Select YES to enable the automatic transfer.
- Select NO to disable the automatic transfer. The setting requires transfers be done manually.

13. Set the AUTO RESTART ENABLE choice.

This setting determines whether the STS2 can be started automatically when power is restored after it has been lost.

- Select YES to enable the automatic restart.
- Select NO to disable the automatic restart. This settings requires a manual restart of the STS2.

14. Select a setting for the I-PEAK RESET.

- Select AUTO to configure the static transfer switch to automatically reset when a fault clears and the voltage and current are normal.
- Select MAN to require a manual reset of the static transfer switch when fault clears and the voltage and current are normal.



CAUTION

Risk of equipment damage and personnel injury.

Use of Auto Restart is site specific. Do not enable auto restart unless the infrastructure is designed for unattended operation and there is no chance of equipment or personnel harm by automatic re-energizing of the system.

Consult with your Liebert site Engineer as to whether Auto restart should be enabled.

System Settings

The System Settings choice under the Config menu displays another pop-up menu with three choices:

- *Comm Options*
- *System Options*
- *System ID*

To access the System Settings menu:

1. Select CONFIG from the menu bar.
2. Select SYSTEM SETTINGS from the Config menu.

Comm Options

The Comm Options dialog box allows you to configure the communications settings for the STS2.

- Select COMM OPTIONS from the System Settings Menu.

The Comm Options dialog box is displayed. See **Figure 56**.

- An option can be enabled by selecting YES.
- An option can be disabled by selecting NO.
- An option can be configured by selecting the adjacent option button to display a separate configuration dialog box.

The instructions for configuring the communications options are provided in this section.

Figure 56 Comm options dialog box

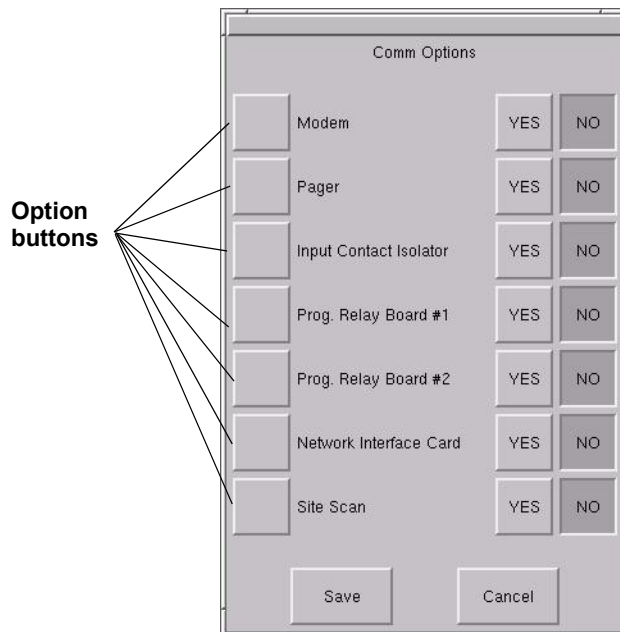

Configuring the Modem

The Modem dialog box allows you to configure the optional, internal modem or an external modem that is connected to the static transfer switch. Only one modem can be utilized by the STS2.

The dialog box contains a series of choices that access either a keypad or a secondary dialog to configure settings. Auto dial can also be configured for the modem to be triggered by events, as set up in the Event Mask choices.

Designated major alarms activate the auto dial modem sequence. Automatic dial attempts are made to the first number three times, at 30 seconds between attempts. If connection is not established in that time period, the system automatically rolls over to the second number. Auto dial attempts are made again three more times at 30 seconds between attempts. The process is repeated until a successful connection is made. Upon successful connection, the system transmits a present status data, including all active alarms messages. After transmission, the modem automatically hangs up and returns to the auto-answer mode.

To configure the modem:

1. Select MODEM from the Comm Options menu.
The Modem dialog box is displayed.

Figure 57 Modem dialog box

2. Select the type of modem that the STS2 will be using:
 - Select INT if the STS2 will be communicating via an internal modem.
 - Select EXT if the STS2 will be communicating via an external modem.
3. Select the PRIMARY LINE choice to enter the primary telephone number for the modem to dial when an alarm is triggered.
4. Enter the number in the keypad dialog box.
5. Select OK to save the telephone number. The number is displayed in the field adjacent to the Primary Line choice.
6. Select the SECONDARY LINE choice to enter the secondary telephone number for the modem to dial when an alarm is triggered.
7. Enter the number in the keypad dialog box.
8. Select OK to save the telephone number. The number is displayed in the field adjacent to the Secondary Line choice.

9. Select INIT. STRING to configure the initialization string.
This string configures the parameters of the modem.
 - This setting only needs to be configured if an external modem is used. Check your modem's documentation for this setting.
 - The string for the internal modem set by the manufacturer and does not need to be changed.
10. Select BAUD RATE to display a dialog with the baud rate choices:
 - For an external modem, select from 2400 bps, 9600 bps or 19200 bps.
 - An internal modem only supports 2400 bps.
11. Configure the MODEM HEALTH CHECK.
The Health Check verifies that the modem is working properly. This setting allows you to enable the check and set when it is run.
 - a. Select the button to display the Modem Health Check dialog box, from which you can access further dialogs to set the time and days that the check is run.
 - b. Select SAVE to keep the settings.
The Health Check dialog box is closed and the Modem dialog box is again active.
 - c. Select YES in the Modem dialog box to activate the Modem Health Check.
If you select NO, the Modem Health Check is not run.
12. Configure AUTO DIAL IN.
Auto Dial In allows a user to dial into the STS2 through the modem to check status and access the system via a hyperterminal connection.
 - a. Select YES to activate the dial in feature.
 - b. Select NO to deactivate the dial in feature.
13. Configure AUTO DIAL OUT.
Auto Dial Out allows the STS2 to automatically dial out to a system to notify a user of an event or status.
 - a. Select YES to activate the dial out feature.
 - b. Select NO to deactivate the dial out feature.
14. Select SAVE to keep the modem configuration settings.
15. Select YES in the Comm Options dialog box to activate the settings.

You are returned to the Comm Options dialog box.

Configuring Pager Support

Pager support will be implemented in an upcoming update of the system. This support will trigger the system to call a pager when specified events occur. This menu choice will allow you to enter the telephone number and PIN for the pager that you want the system to call.

Configuring the Input Contact Isolator Settings

The Input Contact Isolator (ICI) is an optional, eight-channel input board for up to eight external user alarm or message inputs to be routed to the static transfer switch's alarm network.

The contact is set to either be normally open or normally closed. When a contact closes or opens, an event is triggered. See **6.4 - Input Contact Isolator Board** for more information on the ICI.

The Input Contact Isolator options are configured through the Input Contact Isolator dialog box, which is accessed from the Comm Options dialog box. The Input Contact Isolator dialog box contains eight choices to match the eight channel input board. You can label each button to identify the event associated with the contact. When the dialog box is accessed, each button flashes to display the Input Contact Isolator number and the user entered label. This label also appears in the Display Panel when an event related to an Input Isolator Connector is triggered.

The Input Contact Isolator dialog box allows you to:

- Label the input contact assignments for your setup.
- Set the delay for an external event triggering an alarm.
- Review the isolator contact assignments, once the labels are entered.

The delay allows you to set the number of seconds which a condition needs to persist to trigger an alarm.

These input alarms can also be configured to activate a programmable relay output, which is discussed in **Configuring the Programmable Relay Board Settings on page 97**.

To configure the Input Contact Isolator relays:

1. Select INPUT CONTACT ISOLATOR from the Comm Options menu.
The Input Contact Isolator dialog box is displayed.

Figure 58 Input contact isolator dialog box

INPUT CONTACT #	DELAY	Value
INPUT CONTACT #1	DELAY	0.0
INPUT CONTACT #2	DELAY	0.0
INPUT CONTACT #3	DELAY	0.0
INPUT CONTACT #4	DELAY	0.0
INPUT CONTACT #5	DELAY	0.0
INPUT CONTACT #6	DELAY	0.0
INPUT CONTACT #7	DELAY	0.0
INPUT CONTACT #8	DELAY	0.0

Buttons: Save, Cancel

2. Select INPUT CONTACT 1.
A keyboard is displayed to allow you to enter the name of the alarm.
3. Enter the name of the alarm set for that input. For example, a fan problem could be indicated by naming the button FAN.
4. Select OK on the keyboard to keep your label.
5. Select DELAY.
A keypad is displayed prompting you for a delay time, in seconds, for a condition to exist before the alarm is triggered.
6. Enter the delay value. The range for the values are from 0 (zero) to 99.9 seconds.
7. Select OK on the keypad to keep your setting.
The value you entered is displayed in the field adjacent to the corresponding input contact.
8. Repeat steps 2 to 7 for each input contact.
9. Select SAVE after you have configured all input contacts.
Be sure to select Save even if you have accessed this dialog only to change a setting.
10. Enter the settings in **Input Contact Isolator Settings Record on page 141**.
This information is not saved if control power is removed.
11. Select OK in the Comm Options dialog box to activate the settings.

Configuring the Programmable Relay Board Settings

The STS2 can contain up to two Programmable Relay Boards (PRB) that can trigger an external device when an event occurs in the static transfer switch. For example, if Source 1 fails, an external light flashes.

See **6.1 - Programmable Relay Board** for more information on the PRBs.

The Programmable Relay Board dialog box with two options: STANDARD SET and USER DEFINED SET. The STANDARD SET are the factory-configured settings.

The STANDARD SET for the Programmable Relay Board settings are:

Table 15 Standard Settings for Programmable Relays

Relay	Setting	Definition
1	SOURCE 1 FAIL	Source 1 failure.
2	SOURCE 2 FAIL	Source 2 failure.
3	BYPASS CB4 CLOSED	Switch (CB4) is closed, Source 1 is bypassed.
4	BYPASS CB5 CLOSED	Switch (CB 5) is closed, Source 2 is bypassed.
5	TRANSFER INHIBIT	A transfer between Source 1 and Source 2 is being restrained.
6	OUT OF SYNC	The phase difference between sources 1 and 2 exceeds the allowable threshold for transfer,
7	EQUIP OVER TEMP	The ambient temperature of the STS2 exceeds the recommended threshold for operation.
8	blank	No setting.

The USER DEFINED SET allows you to assign faults and alarms to each contact on the relay boards.

Utilizing the USER DEFINED SET, you can also select Input Contact Isolators to associate with a programmable relay.

In addition individual events, three other assignment choices are available:

- **SELECT ALL** sends a *summary* event to the selected relay whenever *any* event occurs. If this setting is selected for a relay, no other event needs to be assigned for that relay.
- **ON SOURCE 1** or **ON SOURCE 2** can be assigned to a relay to send a notification when that source is being used by the load.

Once configured, the static transfer switch continuously checks the status of the items defined for each contact and updates the state of the relay.

To configure your programmable relay boards for user defined settings:

1. Select **PROG. RELAY BOARD # *x*** from the Comm Options dialog box, where *x* is the corresponding board number.

The Prog. Relay Board dialog box is displayed.

Figure 59 Programmable relay board dialog box

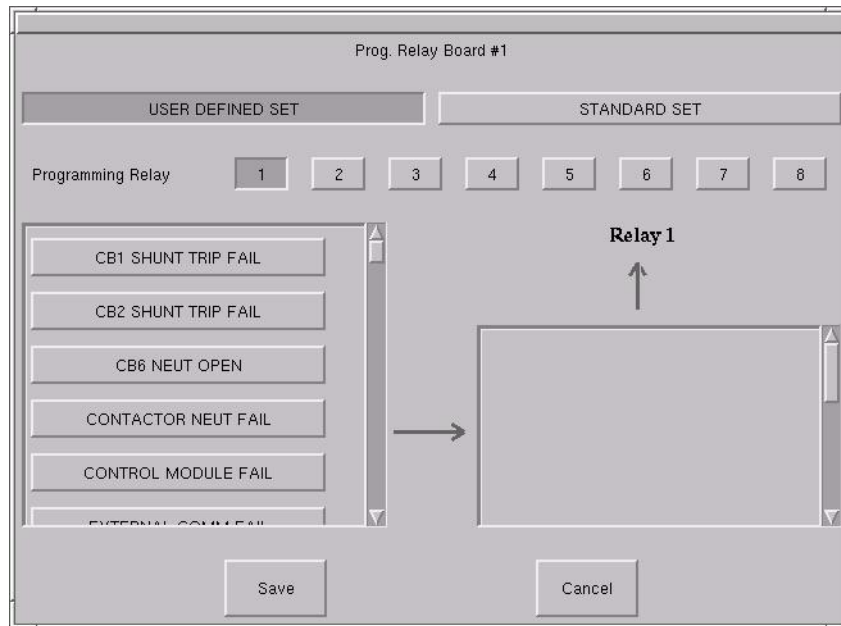

2. Select your configuration settings.
 - Select STANDARD SET to use the settings configured at the factory. See Go to step 4.
 - Select USER DEFINED SET to configure your own settings. Go to step 3.

If you enter a user defined settings, this information is not saved if control power is removed. Record the settings in **Programmable Relay Board Settings Record on page 139**.
3. To define your relay board settings:
 - a. Select a Programming Relay.
 - b. Select an event you want associated with the relay. That fault is placed in the Relay column. You can associate up to ten (10) events with one relay. If you do so, you should group the events logically to simplify troubleshooting when an event is triggered.
4. Select SAVE to keep the settings.
5. Select OK for the applicable Programmable Options Board option in the Comm Options dialog box to activate the settings.

Configuring the Network Interface Card

An optional Liebert OpenComms Network Interface Card (NIC) can be installed in the STS2 to provide Ethernet connectivity via an RJ-45 port.

Ethernet cabling is the responsibility of the customer. Category 5 cabling is required.

See **6.7 - Network Interface Card (NIC)** for more information on the NIC.

See the *OpenComms Network Interface Card Installation and Users Guide* for configuration instructions for the card.

If the optional OpenComm NIC is installed in the STS2:

- Select YES for the Network Interface Card option in the Comm Options dialog box to activate the card.

SiteScan Configuration

An optional RS-422 port, contained in the Comms Board, can be installed in the static transfer switch to provide communications with Liebert's SiteScan. SiteScan is Liebert's system monitoring software that allows you to utilize a PC to monitor the static transfer switch's status and check alarms. See **6.5 - Comms Board** for more information on this board.

If the STS2 will be connected to SiteScan:

- Select YES for the SiteScan choice in the Comm Options dialog box to activate the card.

Saving Your Communications Configurations

To save you communications configuration settings:

1. When you have completed the Comm Options configurations, ensure you have selected YES for all the settings that you want activated.
2. Select SAVE to keep the settings.

Whenever you make modifications to the any of the Comm Options, select SAVE to keep the changes.

System Options

Most System Options are configured at the factory. However, you may need to set two of the choices after the unit is installed: Wye Output Transformer and Remote Source Selection.

- Select SYSTEM OPTIONS from the System Settings Menu.

The System Options dialog box is displayed.

- An option is enabled by selecting YES.
- An option is disabled by selecting NO.

Figure 60 System options

System Options		
Dual Output Breaker	YES	NO
PDU	YES	NO
4 Pole Transfer Switch	YES	NO
Shunt Trip	YES	NO
Wye Output Transformer	YES	NO
Remote Source Select	YES	NO
Save		Cancel

Dual Output Breaker

This selection is set at the factory. The choice is set to YES to enable both output breakers (CB3 and CB3A) when two are installed in the unit. If only one output breaker (CB3) is installed, the setting is set to NO.

PDU

This selection is set at the factory. This setting allows the LCD to draw the Mimic accordingly and display PDU specific metering and alarm information.

4 Pole Transfer Switch

This selection is set at the factory to indicate whether the system is a 3 pole or 4 pole unit.

Shunt

This selection is set at the factory.

Wye Output Transformer

The Wye Output Transformer controls the firing of the SCRs on startup, which minimizes the inrush into PDU transformers. Output breakers and PDU input breakers have to be closed when you start up the system. Based on whether the input side of the PDU transformer is configured as a Wye or Delta changes the firing sequence of the SCRs.

If the STS2 is connected to a PDU configured as a Wye:

- Select YES for the Wye Output Transformer choice in the System Options dialog box.

Remote Source Selection

If your system is configured with the optional Remote Source Selection, it must be enabled from the System Options menu. See **5.5 - Remote Source Selection Wiring** for more information.

If the system is utilizing Remote Source Selection:

- Select YES for the Remote Source Selection choice in the System Options dialog box to activate the option.

System ID

Most of the settings for System ID are set by Liebert either at the factory or when the unit is installed.

Order No., System Tag No., System ID No. and Model No. are the numbers used to identify and track the system.

Language, Time and Date are synchronized with the location of the unit.

The only configurable field is the Password. See **Using the Password on page 87** for more information on configuring and using the password.

13.6.2 Logs

Two types of logs are kept by the STS2: Event Log and History Log.

Event Log

The Event Log tracks the alarms and faults of the STS2.

See 11.0 - Alarm and Faults for more information on these events and see 11.2.1 - Event Log for more information on the Event Log and definitions of the fields displayed in the Event Log screen.

Figure 61 Event log

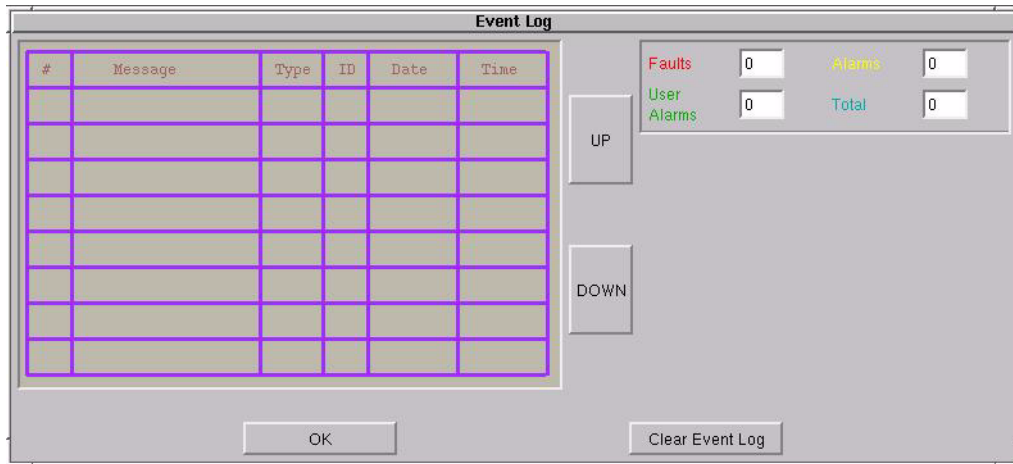

To use the Event Log:

1. Select LOGS from the menu bar to open the Logs menu.
2. Select EVENT LOG from the menu.
3. Use the UP and DOWN buttons to scroll through the event list.
4. Select OK to close the Event Log. The data remains in the log.

History Log

Two History Logs are available to track major alarms. If so configured, an alarm freezes the history buffer. When the History Status buffer is frozen, a History Log is created that can be accessed from the HISTORY LOG x choices in the LOGS menu.

See 11.2.2 - History Log for more information on the History Logs and definitions of the fields displayed in the History Log screen.

Figure 62 History log

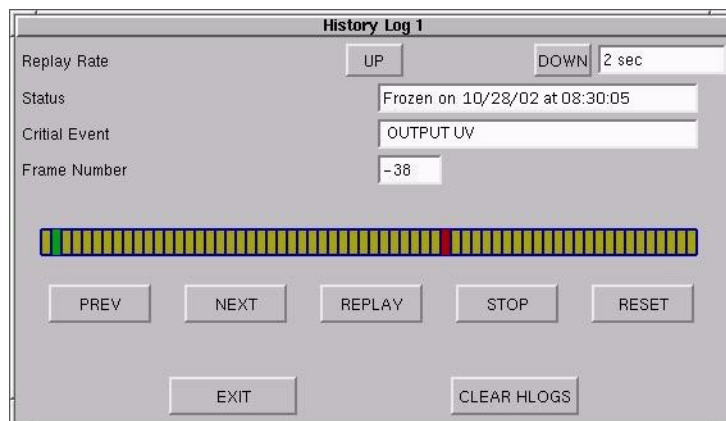

To use the History Log:

1. Select LOGS from the menu bar to open the Logs menu.
2. Select either HISTORY LOG 1 or HISTORY LOG 2 from the menu.
3. Select the appropriate buttons to replay the log:
 - Select PREV to go to the previous frame in the sequence.
 - Select NEXT to go to the next frame in the sequence.
 - Move the green cursor to the location from which you would like to play the sequence of events.
 - Select REPLAY to play the frames automatically from the point of the cursor.
 - Select STOP to halt the replay.
 - Select RESET to return to the first frame in the log.
4. Select EXIT to close the History Log. The data remains in the log.
 - Use CLEAR HLOGS to remove the data from both history logs.

**NOTE**

Event and History Logs are protected by security. The password or a disabled key lockout is required on such equipped units to clear these logs.

13.6.3 Source Transfers

The Source Transfer choice (SOURCE XFERS) allows you to manually select a preferred source.

To switch the primary source, refer to the instructions in **10.2 - Manual Transfer / Preferred Source Selection**.

13.6.4 Startup Procedure

You can access instructions for starting the STS2 from the menu bar.

- From the menu bar, select STARTUP PROC.

These instructions are also provided on **10.1 - Normal System Turn-On** for Color Graphical display units and **14.2.1 - Normal System Turn-On** for LED Display units.

13.6.5 Bypass Procedure

You can access instructions for bypassing the static transfer switch from the menu bar.

- From the menu bar, select BYP. PROC.

The instructions are provided in the display panel.

Bypass procedures are also discussed in **10.4 - Maintenance Bypass** for Color Graphical display units and **14.2.3 - Maintenance Bypass** for LED Display units.

13.6.6 Help

You can select an event in the Event Display to display more information about that event in the Display Panel. This same help is also available in **16.0 - Event Message Help Text**.

13.6.7 Logo

The Logo menu choice shows the Liebert and Emerson logo in the Display panel.

13.7 Cleaning the LCD Touch Screen

If the touch screen requires cleaning, use a pre-moistened towelette designed for cleaning CRTs, or dampen a soft, non-abrasive cloth with a very mild cleaning solution.

Do not spray the cleaner directly onto the touch screen, as drips may run down into the screen and damage the equipment.

Close all menus and dialog boxes before cleaning the touch screen.

14.0 OPERATING THE LED DISPLAY STS2

Certain models of the STS2 do not include the LCD Color Graphical Display with the touch screen interface. This display is replaced by an LED front panel to allow you to monitor the unit and alert you when a problem occurs. The LED panel can be replaced with the Color Graphical Display, if desired. Instructions for using the LCD are in 13.0 - STS2 Touch Screen Display.

You can use a PC running terminal emulation software connected to the RS-232 port to access the data and configuration settings that are available in the Color Graphical Display touch screen.

See 12.1 - Using the RS-232 Port for instructions on setting up and using a terminal with the unit.

14.1 LEDs and Buttons and Key Lockout Switch

The LED Display unit is monitored and controlled through a series of LEDs and buttons and an optional key lockout switch. This section includes illustrations of the LEDs, buttons and key lockout switch, plus tables providing definitions of these components.

14.1.1 Front Panel Controls

The front panel contains the LEDs to monitor the STS2, plus selection buttons to choose the preferred source. Figure 63 provides a breakdown of the front panel.

Table 16 on page 104 defines the LEDs and the push buttons on the display.

Figure 63 LED display

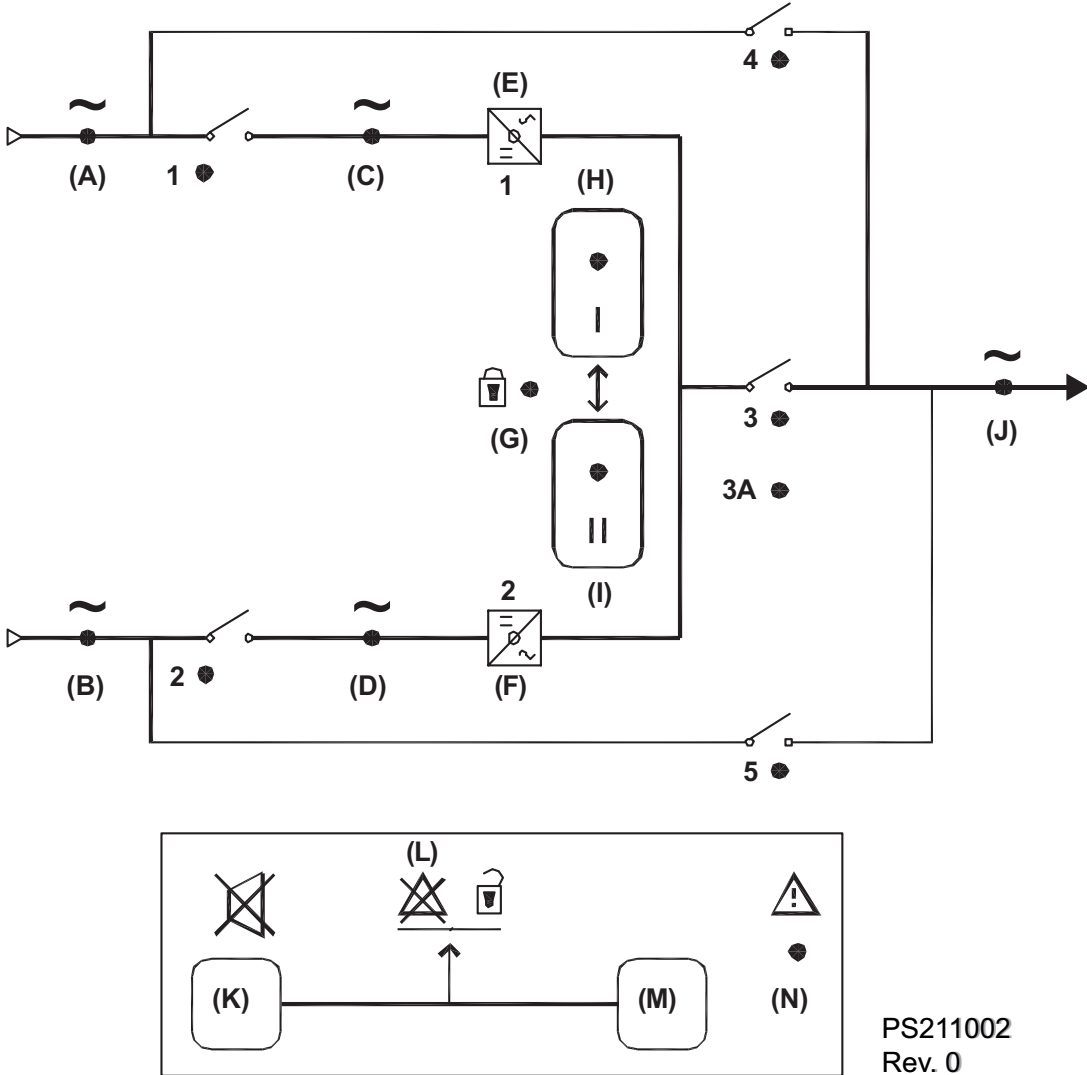

PS211002
Rev. 0

14.1.2 LED and push button description

The following table defines the LEDs and pushbuttons in the LED display:

Table 16 LED and push button description

Symbol	LED	Description	Action
A	Green	Source 1 power is present	A green LED is lit if the Source 1 input power is present. This LED only indicates that power is present to the power supply; it does not indicate if the power is within the programmed tolerances of the unit.
B	Green	Source 2 power is present	A green LED is lit if the Source 2 input power is present. This LED only indicates that power is present to the power supply; it does not indicate if the power is within the programmed tolerances of the unit.
C	Green	Source 1 within tolerance	A green LED is lit if Source 1 power is within the programmed tolerance for all phases.
D	Green	Source 2 within tolerance	A green LED is lit if Source 2 power is within the programmed tolerance for all phases.
E	Green	Source 1 SCRs on	A green LED is lit when the SCRs for Source 1 are closed.
F	Green	Source 2 SCRs on	A green LED is lit when the SCRs for Source 2 are closed.
G	Yellow	Source transfer inhibited	A yellow (amber) LED is lit when source transfers are inhibited (locked out) by a hardware condition. Connect a PC terminal to the STS2 to locate the exact cause. See 12.0 - Communication Interfaces for PC terminal commands.
H	Green	Push button to select Source 1 as the preferred source	A green LED is lit if the button has been pushed to set Source 1 as the preferred source.
I	Green	Push button to select Source 2 as the preferred source	A green LED is lit if the button has been pushed to set Source 2 as the preferred source.
J	Green	Output power is present	A green LED is lit to indicate that power is present on the output load.
K		Alarm silence button	Push this button to turn off the horn that is sounded for an alarm. This button does not reset an alarm condition, unless pushed simultaneously with "M" button.
L		Symbol to indicate the K and M must be pushed at the same time to reset alarm	
M		Alarm reset push button	Push this button simultaneously with the "K" button to reset an alarm condition. An alarm can only be reset if the hardware condition permits a reset.
N	Red	Alarm present	A red LED is lit when an alarm condition is present in the STS2. Connect a PC terminal to the STS2 to locate the exact cause. See 12.0 - Communication Interfaces for PC terminal commands.
1	Green	CB1 closed	A green LED is lit if CB1 is closed, indicating power is flowing to the static transfer switch from Source 1.
2	Green	CB2 closed	A green LED is lit if CB2 is closed, indicating power is flowing to the static transfer switch from Source 2.
3	Green	CB3 closed	A green LED is lit if the output breaker/switch is closed.
3A	Green	CB3A closed	A green LED is lit if the output breaker/switch is closed. CB3A is installed on units with dual output breakers.
4	Yellow	CB4 closed	A yellow LED is lit if the Source 1 bypass breaker/switch is closed.
5	Yellow	CB5 closed	A yellow LED is lit if the Source 2 bypass breaker/switch is closed.

14.1.3 Event Controls

When an alarm is triggered, a red LED is lit in the control panel. A pair of buttons allows you to turn off the horn and reset the alarm.

14.1.4 Key Lockout Switch

An optional key lockout switch for the STS2 enables or disables all push button inputs, except for the alarm silence button. The key lockout switch is mounted on the front of the unit. See **Figures 8 to 10** for the key lockout switch location on each unit.

- To disable the buttons, turn the key to the top of the switch, toward the closed padlock icon.
- To enable all of the buttons, except the alarm silence, turn the key to the horizontal position, toward the open padlock icon.

Figure 64 Key lockout switch.

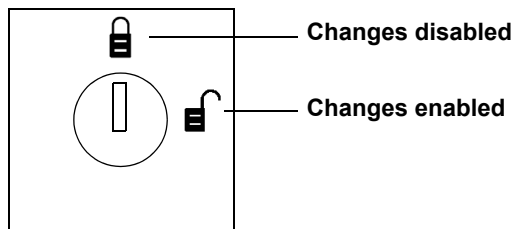

14.2 Operations

This section discusses the system turn-on, shut-down and bypass procedures for LED-based STS2.

If your unit has an LCD touch screen, see **10.0 - Operating Instructions for the Touch Screen Interface** for instructions these procedures.

14.2.1 Normal System Turn-On



NOTE

*If your STS2 is connected to a PDU with a Wye configuration, enable the Wye Output Transformer before starting the system. This configuration can be done from a PC terminal. Refer to **12.1 - Using the RS-232 Port** for instructions.*

This section provides instructions to turn on your STS2. The LEDs provide the basic information required to ensure proper operation. To monitor metering data, use a PC terminal.

1. Ensure that all STS2 breakers—CB1, CB2, CB3A (if supplied), CB3, CB4, and CB5—are in the OFF (open) position.
 - a. Ensure that the key interlocks for CB1 and CB2 have their bolts retracted.
 - b. Ensure that the key interlocks for CB4 and CB5 have their bolts extended, thus preventing CB4 or CB5 from being turned ON.
 - c. Ensure that the circuit breakers respective LEDs are off.
2. Source/input power should be applied to both STS2 inputs.
Check that the green LEDs for each source are lit.
3. Verify that nominal input voltages are applied to both inputs (Source 1 and Source 2).
Check that the green LEDs monitoring the sources are lit indicating the sources are within acceptable tolerances.



NOTE

For redundant output switch units, CB3 descriptions apply to CB3 and CB3A.

4. Close CB1.
The green LED monitoring CB1 turns on.
5. Close CB2.
The green LED for CB2 turns on.

6. Verify that the preferred source LED (green) (LED_PREFx) is lit for the source that you want the switch to be using.
7. Verify that the green LED for the corresponding SCR (STS1 or STS2) is lit, indicating that the SCR is closed.
8. Close Output Breaker CB3 (and CB3A in a redundant output configuration).
9. Verify the CB3 LED is lit, indicating that CB3 is closed and the output and load are energized.
 - In a redundant output configuration, verify the CB3A LED is lit, indicating that CB3A is closed and the output and load are energized
10. Press the Reset and Silence buttons simultaneously to reset any previous alarms.
11. Verify that no red or yellow (amber) LEDs are lit indicating an active alarm, transfer is inhibited or a bypass circuit breaker is closed.

If the alarm LED remains lit, check the PC terminal to identify the alarm. Refer to **11.0 - Alarm and Faults** for a description of the alarms and possible causes. All active alarm conditions should be corrected before proceeding.
12. If the unit is supplied with an output distribution cabinet, close output breakers as required.
13. Turn on the load equipment following the load equipment manufacturer's recommendations.

14.2.2 Manual Transfer / Preferred Source Selection

The preferred source buttons allow you to change the preferred source. Transfers are only permitted when the voltage and current are within their proper operating range and the sources are synchronized. Transfer is inhibited if the deviation exceeds the parameter set in the Source Set Points.



NOTE

*If one source will be de-energized for an extended period (hours or days), set the unit to bypass mode for the remaining source. Without using bypass, if a failure occurs in the switch components for remaining source, the STS2 does not have a second source to switch to and the load would not receive power. See **14.2.3 - Maintenance Bypass** on page 107 for bypass instructions.*

To manually select the preferred source:

1. Ensure that the Transfer Inhibit (NOXF) LED is not lit.

If the Transfer Inhibit LED is lit:

 - Check to see if the red alarm LED is lit.
 - If the alarm LED is lit, check the alarm messages on a PC terminal.
 - Correct alarm conditions before attempting a source transfer.



NOTE

When the remote source selection option (Remote Control) is activated, a change of state (Remote Preferred Source Selection) may initiate a transfer if the appropriate contacts are closed.

2. Verify that the LEDs are lit for both sources, indicating power is present and within acceptable tolerances.
3. Verify that the LEDs for the SCRs (STS1 and STS2) are lit.
4. Verify that the input breakers CB1 and CB2 are closed.
 - Verify that their respective LEDs are lit.
5. Push the Preferred Source button for the desired source. See **Table 16** on page 104.

The Preferred Source (LED_PREFx) LED turns on for that source.

When conditions are correct, the switch transfers the load to the alternate source by selecting the alternate source as the preferred source.

This source is now monitored as the preferred source throughout the various configurations set up through the PC terminal.
6. Check the LEDs to verify that the correct source is designated as the preferred source and that the input source changes to the desired source and the output (OUT) LED remains lit.

14.2.3 Maintenance Bypass

The STS2 is equipped with two key-interlocked, bypass breakers, CB4 and CB5, to allow manual bypass of the switch electronics for either input source in the event of switch failure or for maintenance of the switch. Refer to the static transfer switch one-line diagram (**Figure 3**). While operating on maintenance bypass, all voltages are removed from the STS2 electronics to facilitate safe repair, without de-energizing the load using a make-before-break switching sequence.

However, the unit can be bypassed using a make-before-break switching sequence only to the same source to which that the switch is connected.

In the event of source or switch failure, the unit should be bypassed only to the current input source.

Bypass Procedures for Source 1

If transfer to Source 2 is not desired:

1. Follow the instructions to transfer the load to Source 1, if it is not the currently used source.
2. Remove the interlock key from CB5 and place it in CB4 interlock.
3. Open the alternate source input breaker CB2.
The CB2 LED is turned off.
4. Rotate and remove the interlock key.
5. Insert the key into the CB4 bypass breaker interlock.
6. Rotate interlock keys in the CB4 bypass breaker interlock to retract the interlock.
7. Close bypass breaker CB4.
The LED for CB4 turns on.
8. Open source input breaker CB1.
9. Rotate the interlock key and remove it to lockout the breaker.
The LED for CB1 turns off.
10. Open the output breakers CB3 and CB3A (if supplied) to remove power from static switch.
The LEDs for CB3 and CB3A (if supplied) turn off.
11. Verify that the output (OUT) LED is lit.

Power is now flowing directly from the source to the load, without passing through the static transfer switch.

To return to the normal mode:

1. Verify that the LEDs for Source 1 are on, indicating that the source is supplying power and is operating within acceptable tolerances.
2. Remove the key from CB5 and insert it in the CB1 breaker interlock.
3. Rotate key to retract interlock.
4. Close source input breaker CB1.
The LED for CB1 turns on.
5. Close the output breakers CB3 and CB3A (if supplied).
The LEDs for CB3 and CB3A are lit.
6. Open bypass breaker CB4. Rotate keys in CB4 interlock to extend interlock.
The LED for CB4 is turned off.
7. Remove proper key from CB4 interlock and insert it in CB2 breaker interlock.
8. Rotate the key to retract CB2 breaker interlock.
9. Close source input breaker CB2.
The LED for CB2 is turned on.
10. Verify that the output LED is lit.

Bypass Procedures for Source 2

If transfer to Source 1 is not desired:

1. Follow the instructions to transfer the load to Source 2, if it is not the currently used source.
2. Remove the interlock key from CB4 and place it in CB5 interlock.
3. Open the alternate source input breaker CB1.
The LED for CB1 is turned off.
4. Rotate and remove the interlock key.
5. Insert the key into the CB5 bypass breaker interlock and rotate the interlock keys in CB5 bypass breaker interlock to retract the interlock.
6. Close bypass breaker CB5.
The LED for CB5 is turned on.
7. Open source input breaker CB2.
The LED for CB2 is turned off.
8. Rotate the interlock key and remove it to lockout the breaker.
9. Open output breakers CB3 and CB3A (if supplied) to remove power from static switch.
The LEDs for CB3 and CB3A (if supplied) turn off.
10. Verify that the output LED is lit.

Power is now flowing directly from the source to the load, without passing through the static transfer switch.

To return to normal mode:

1. Verify that the LEDs for Source 2 are on, indicating that the source is supplying power and is operating within acceptable tolerances.
2. Insert key in the CB2 breaker interlock.
3. Rotate key to retract interlock.
4. Close source input breaker CB2.
The LED for CB2 is turned on.
5. Close output breakers CB3 and CB3A (if supplied).
The LEDs for CB3 and CB3A (if supplied) turn on.
6. Open bypass breaker CB5.
The LED for CB5 is turned off.
7. Rotate keys in CB5 interlock to extend interlock.
8. Remove the proper key from CB5 interlock and insert it in CB1 breaker interlock.
9. Rotate key to retract CB1 breaker interlock.
10. Close source input breaker CB1.
The LED for CB1 is turned on.
11. Verify that the output LED is lit.

14.2.4 Normal System Shutdown

The STS2 can be shut down from either the static switch mode or the bypass mode.

Shutdown in Static Transfer Switch Mode

When the Static Transfer Switch is operating on static transfer switch mode (not maintenance bypass mode):

1. Turn off the load equipment per manufacturer's recommendations.
2. Open CB3 to turn off the static switch output.
 - Open CB3A if the static transfer switch is a redundant output configuration.The LEDs for CB3 and CB3A (if supplied) and the output (OUT) are turned off.
3. Open the input switches CB1 and CB2.
The LEDs for CB1 and CB2 are turned off.
4. To completely de-energize the unit, turn OFF the power to both inputs to the STS2.

Shutdown in Maintenance Bypass Mode

When the Static Transfer Switch is operating on bypass:

1. Turn off the load equipment per manufacturer's recommendations.
2. Open the bypass switch (CB4 or CB5) to turn off the static transfer switch output.
The LED for the bypass switch is turned off.
The output (OUT) LED is turned off.
3. To completely de-energize the unit, turn OFF the power to both inputs to the STS2.

15.0 SPECIFICATIONS

This section provides the specifications for the STS2.

15.1 System Configuration

The STS2 can be set in several different configurations, according to the model and location. The configuration is set at the factory and does not need to be changed by the customer. These configurations apply to both units, the Color Graphical Display and an LED Display.

15.1.1 Frequency

The STS2 accepts input frequencies of 50 Hz and 60 Hz. The frequency shall be within +/- 0.5 Hz of the nominal frequency.

15.1.2 Input/Output Voltage

The STS2 models are available to handle various voltages.

The input voltage must be three phase AC (3 or 4 wire-plus-ground). The STS2 is designed to accept an input neutral from each source. The neutral is switched in the 4-pole static transfer switch only.

The voltage shall be within +/- 10% of the nominal voltage.

The output voltage shall be three phase AC (3 or 4 wire-plus-ground). Nominal output voltage shall be same as input voltage.

The following table provides nominal voltages, listed according to frequency

Table 17 Input/Output Voltage

60Hz	50 Hz
[L-L/L-N]	[L-L/L-N]
200/115V	200/115V
208/120V	208/120V
220/127V	220/127V
240/139V	240/139V
380/220V	380/220V
400/230V	400/230V
415/240V	415/240V
480/277V	
600/346V	

15.1.3 System Current Ratings

These ratings are based upon continuous switch current rating. These ratings are for all voltages and frequencies. All units are 100% continuous current rated.

Table 18 System Current Ratings

Current
100
250
400
600
800
1000

15.1.4 Grounding

Refer to 5.3 - **System Grounding** for specifications and instructions regarding grounding.

15.1.5 Electrical Requirements

Table 19 Electrical Requirements

Item	Requirement
Maximum Continuous Current	100, 250, 400, 600, 800, 1000 amps
Load Power Factor Range	0.75 to 1.0, leading or lagging
Load Crest Factor	Up to 3.5
Source Voltage Distortion	Up to 10% THD with notches and ringing transients
Overload Capability	125% for 30 minutes 100A-400A
	125% for 10 minutes 600A-1000A
	150% for 2 minutes
	500% for 0.25 sec.

Table 20 Unit Short Circuit Withstand Capability

Unit Voltage	Unit Amps	Withstand Capability
208-240V	100-250A	100kA
	400-600A	100kA
	800-1000A	100kA
380-480V	100-250A	65kA
	400-600A	100kA
	800-1000A	65kA
600V	100-250A	25kA
	400-600A	25kA
	800-1000A	42kA

15.1.6 Input Surge Suppression

The STS2 is equipped with transient voltage surge suppression on each input for maximum surge suppression. The surge suppression is capable of protecting the STS2 from operating outside of tolerances due to surges as defined by IEC 1000-4-5 (1.2/50uS surge, 2kV CM and 1kV DM) as required under EN 50091-2.

15.1.7 Response Time

A dual level fast/slow transfer threshold is used for under voltage detection to allow the STS2 to be compatible with UPSs and generators. The voltage thresholds and the slow transfer delay time is user-adjustable. The fast transfer delay time is less than 4 ms.

The over voltage detection uses a single threshold, with programmable level and delay time.

See **User Settings on page 89** for instructions on configuring these settings.

15.1.8 Environmental Requirements

See **3.0 - Location Considerations** for details concerning environmental requirements for the STS2.

15.2 System Components

All STS2 models provide two static transfer switches within one enclosure, with the ability to transfer between two input sources to a single output.

All STS2s are configured with either an LCD Color Graphical Interface touch screen display or LEDs for monitoring and configuring the unit.

This section lists the common components and the differences for both types of units.

15.2.1 Frame and Enclosure

The complete STS2 is housed in a freestanding enclosure. The cabinet is a NEMA type 1 enclosure and meets IP20 requirements. The cabinet is structurally designed to handle lifting from the base. The frame is designed to accommodate floor stands.

Table 21 Frame Sizes

Rating	Width	Depth	Height
100 – 250A 3 pole	30 in (76 cm)	32 in (81 cm)	76.77 in (195 cm)
400 – 600A 3 pole	38 in (96 cm)	32 in (81 cm)	76.77 in (195 cm)
800 – 1000A 3 pole	84 in (213 cm)	32 in (81 cm)	76.77 in (195 cm)

The distributed floor weight for STS2 is less than 150 lbs./sq. ft. (660kg/m²).

The required service access is only from the front of the unit.

The STS2 can be tipped 15° in any direction without falling over.

15.2.2 Castors, Leveling and Seismic Anchoring

The frame includes heavy-duty swivel castors for ease of installation, plus permanent leveling feet for final installation.

The unit also can be fastened to the floor using optional seismic anchors to meet seismic Zone 4 requirements. See **4.0 - Locating the STS2** and **Figures 11** through **13** for instructions and details for installing seismic anchoring.

15.2.3 Cooling

The STS2 100 – 600A units utilize convection air cooling for the enclosure with forced air cooling of the heat sinks. The 800-1000A units are fan cooled using low-velocity fans to minimize audible noise. All fans are redundant so that a single fan failure cannot cause temperatures to increase beyond acceptable limits.

Air intake is through screened protective openings in the front of the unit. A standard furnace filter is installed behind the openings.

By opening the front door, the filter can be changed easily without exposing personnel to high voltage.

The size of the filter is 1 in. x 25 in. x 25 in. (2.54 cm x 63.5 cm x 63.5 cm).

The air exhaust is through the top of the unit.

15.2.4 Access

The STS2 is designed so all repairs and maintenance can be done from the front or top of the unit. All components that may need repair or replacement during routine field maintenance are safely accessed with the units in bypass without removing power from the unit. These components include:

- All electronic PCB assemblies
- Power supply assemblies
- All fuses
- All circuit breaker plug-in modules
- Fans
- SCRs

All power connections are designed to maintain proper connection torque over the lifetime of the unit without any maintenance. The integrity of the connections can be checked via infrared scanning safely from the front or top of the unit.

All other components including power cables and connections, circuit breaker bases, etc. are replaceable from the front or top of the unit only, but this requires all power to be removed from the unit for safety. Although routine re-torquing of the power connections is not required, if maintenance of these connections is needed, complete removal of power is required from the unit for safety reasons.



WARNING

Lethal voltages exist inside the unit during normal operation. Only qualified service personnel should perform maintenance on the static switch.

The unit is supplied by more than one power source. The unit contains hazardous voltages if any of the input sources is ON, even when the unit is in bypass. To isolate the unit, turn OFF and lock out ALL input power sources.

Verify that all input power sources are de-energized and locked out before making connections inside unit.

15.2.5 Circuit Breakers

The STS2 is equipped with five molded-case, plug-in, non-automatic circuit breakers. The breakers are UL listed for use up to 600 VAC and CE marked. The plug-in feature of the breaker includes an interlock, which prevents the breaker from being unplugged without being in the OFF (open) position.

Mechanical interlocks are provided on the breakers to prevent improper maintenance bypassing of the solid-state switch. A bypass breaker cannot be closed unless the solid-state switch is connected to the same input source and only one bypass breaker can be closed at a time. All breakers are equipped with N.O. and N.C. auxiliary switches for monitoring of the breaker positions. The two input breakers for the solid-state switching devices also are equipped with 48 VDC shunt trips to allow for control by the STS2 logic. See the Circuit Breaker Schedule in *Figure 20*.

15.2.6 Cable Entrance

Removable conduit termination plates are provided in the top and bottom of the STS2 for termination of the two source input conduits or raceways and/or the output conduits or raceways.

15.2.7 Doors

A removable key lock hinged front door provides access to the circuit breakers.

15.2.8 Color Graphical Display or LED Display

The display is located in the front of the unit. Front panel display is either an LCD touch screen display for monitoring and configuring the unit, or an LED panel to monitor the unit's status.

See *Figure 31* for a drawing of the touch screen display. See *Figure 63* for the layout of the LED display.

15.2.9 RS-232 Port

The unit is equipped with an RS-232 port for connecting a terminal or PC.

See *Figure 29* for the port's location.

See **12.1 - Using the RS-232 Port** for instructions on using a PC terminal with the unit.

15.2.10 Terminal Port Connections

The system has an asynchronous serial port configured as Data Terminal Equipment for terminal access only (half duplex). The CPU services the terminal port with no handshaking. The serial port conforms to RS-232 levels with a data format of 9600 Baud, 1 start bit, 8 data bits, and no parity bits. The serial port is 1000 Volt DC isolated (non-SELV) and ESD protected to 15kV air discharge. The connector is a 6 Pin MTA plug with connections shown below.

Table 22 MTA Plug Pinout

Pin	Signal Name	Function / Comments
1	ISO_GND	Isolated service terminal ground
2	ISO_TXD	Isolated service terminal transmit output
3	ISO_RXD	Isolated service terminal receive input
4	NC	No Connection
5	NC	No Connection
6	NC	No Connection

A DB9 male connector is added and connected parallel to the 6 position header. It is configured as DTE.

Table 23 DB9 Pinout

Pin	Signal Name	Function / Comments
1	NC	No Connection
2	ISO_RXD	Isolated service terminal transmit output
3	ISO_TXD	Isolated service terminal receive input
4	NC	No Connection
5	ISO_GND	Isolated service terminal ground
6	NC	No Connection
7	NC	No Connection
8	NC	No Connection
9	NC	No Connection

15.2.11RS-232 Interface Parameters

The service terminal interface parameters are the following settings and cannot be changed.

Table 24 RS-232 Settings

Parameter	Setting
Interface	RS-232 Using EIA Voltage Levels
Baud Rate	9600
Parity	None
Number of Data Bits	8
Number of Stop Bits	1
Hardware Flow Control	Off
Terminator	<CR> <LF>
Handshaking	Not supported
Structure	Full duplex
Local Echo	Off

15.2.12Maintenance Bypass

The STS2 is configured to allow the unit's electronics to be bypassed to either input source for maintenance without interruption of power to the load.

The STS2 is furnished with key-interlocked maintenance bypass breakers to configure the bypass.

STS2 units have all electronics isolated from the input, output, and bypass connections to allow safe servicing of any components without access to hazardous voltages when the unit is in maintenance bypass.

See **10.4 - Maintenance Bypass** on page 67 for instructions using the Color LCD Graphical Display unit and **14.2.3 - Maintenance Bypass** on page 107 for instructions using the LED units.

15.2.13Fuseless Design

All STS2 units are fuseless and are UL rated for use with upstream circuit breakers only.

15.2.14Options

The following options are available for the STS2:

Optimized Transfer	LED Display
Redundant Output Breaker	Network Interface Card (NIC)
Distribution Cabinet With I-Line Panelboard	Seismic Floor Stand - 18", 24", 30" and 36"
Input Junction Boxes and Cable	Export Crating
Comms Board w/SiteScan and Modem Interface	Internal Modem
Input Contact Isolator Board	Remote Source Selection
Programmable Relay Board	Key Lockout Switch

See **6.0 - Options** for more information.

16.0 EVENT MESSAGE HELP TEXT

Key:

ALL CAPS = event message displayed in the Event Display panel in the lower left corner of the LCD display.

Indented text = help text shown in the Display Panel in the lower right corner of LCD display.

BOLD = commands that are sent through the RS-232 port.

S1 SCR SHORT

Source 1 SCR Short.

One or more of the SCRs for Source 1 has shorted. Transferring between sources has been inhibited.

Contact Liebert for technical support at 1-800-LIEBERT (800-543-2378).

Press SILENCE on the touch screen to turn off the audible alarm, if so configured. If you are accessing the STS2 system from a terminal, type **SH** and press RETURN on your keyboard to turn off the audible alarm.

This event and the system status surrounding it have been written to a History Log if the History Logs were not already full. This event was also written to the Event Log, if so configured.

The alarm has triggered a message to be sent to the modem, if so configured.

S2 SCR SHORT

Source 2 SCR Short.

One or more of the SCRs for Source 2 has shorted. Transferring between sources has been inhibited.

Press SILENCE on the touch screen to turn off the audible alarm, if so configured. If you are accessing the STS2 system from a terminal, type **SH** and press RETURN on your keyboard to turn off the audible alarm.

This event and the system status surrounding it have been written to a History Log if the History Logs were not already full. This event was also written to the Event Log, if so configured.

The alarm has triggered a message to be sent to the modem, if so configured.

S1 SCR OPEN

Source 1 SCR Open.

One or more SCRs on Source 1 is open. Transferring between sources has been inhibited.

Contact Liebert for technical support at 1-800-LIEBERT (800-543-2378).

STS2 output has been transferred to Source 2.

Press SILENCE on the touch screen to turn off the audible alarm, if so configured. If you are accessing the STS2 system from a terminal, type **SH** and press RETURN on your keyboard to turn off the audible alarm.

This event and the system status surrounding it have been written to a History Log if the History Logs were not already full. This event was also written to the Event Log, if so configured.

The alarm has triggered a message to be sent to the modem, if so configured.

S2 SCR OPEN

Source 2 SCR Open.

One or more SCRs on Source 2 is open. Transferring between sources has been inhibited.

STS2 output has been transferred to Source 1.

Contact Liebert for technical support at 1-800-LIEBERT (800-543-2378).

Press SILENCE on the touch screen to turn off the audible alarm, if so configured. If you are accessing the STS2 system from a terminal, type **SH** and press RETURN on your keyboard to turn off the audible alarm.

This event and the system status surrounding it have been written to a History Log if the History Logs were not already full. This event was also written to the Event Log, if so configured.

The alarm has triggered a message to be sent to the modem, if so configured.

PRIMARY FAN FAIL

Primary Fan Failure

One of the primary cooling fans for the STS2 has failed. The alternate fans are now running. The alternate fans are not monitored.

Contact Liebert for technical support at 1-800-LIEBERT (800-543-2378).

Press SILENCE on the touch screen to turn off the audible alarm, if so configured. If you are accessing the STS2 system from a terminal, type **SH** and press RETURN on your keyboard to turn off the audible alarm.

This event was written to the Event Log, if so configured.

The alarm has triggered a message to be sent to the modem, if so configured.

CONTROL MODULE FAIL

Control logic module has failed.

One of the control modules on the control board has failed.

Contact Liebert for technical support at 1-800-LIEBERT (800-543-2378).

Press SILENCE on the touch screen to turn off the audible alarm, if so configured. If you are accessing the STS2 system from a terminal, type **SH** and press RETURN on your keyboard to turn off the audible alarm.

This event was written to the Event Log, if so configured.

The alarm has triggered a message to be sent to the modem, if so configured.

If configured to be a latching alarm, press RESET on the display. If you are accessing the unit from a terminal, type **CA** and press RETURN on your keyboard.

PWR SPLY DC A FAIL

Power Supply DC Bus A Failed

The primary power supply is no longer providing DC power to the control board and the touch screen.

Contact Liebert for technical support at 1-800-LIEBERT (800-543-2378).

Press SILENCE on the touch screen to turn off the audible alarm, if so configured. If you are accessing the STS2 system from a terminal, type **SH** and press RETURN on your keyboard to turn off the audible alarm.

This event was written to the Event Log, if so configured.

The alarm has triggered a message to be sent to the modem, if so configured.

If configured to be a latching alarm, press RESET on the display. If you are accessing the unit from a terminal, type **CA** and press RETURN on your keyboard.

PWR SPLY DC B FAIL

Power Supply DC Bus B Failed

The secondary power supply is no longer providing DC power to the control board and CAN options.

Contact Liebert for technical support at 1-800-LIEBERT (800-543-2378).

Press SILENCE on the touch screen to turn off the audible alarm, if so configured. If you are accessing the STS2 system from a terminal, type **SH** and press RETURN on your keyboard to turn off the audible alarm.

This event was written to the Event Log, if so configured.

The alarm has triggered a message to be sent to the modem, if so configured.

If configured to be a latching alarm, press RESET on the display. If you are accessing the unit from a terminal, type **CA** and press RETURN on your keyboard.

PWR SPLY S1 AC FAIL

Power Supply Source 1 AC Failed

The AC input power to the power supplies from Source 1 has failed. The power supplies are now operating on AC power from Source 2. The AC input from Source 1 is still good.

Contact Liebert for technical support at 1-800-LIEBERT (800-543-2378).

Press SILENCE on the touch screen to turn off the audible alarm, if so configured. If you are accessing the STS2 system from a terminal, type **SH** and press RETURN on your keyboard to turn off the audible alarm.

This event was written to the Event Log, if so configured.

The alarm has triggered a message to be sent to the modem, if so configured.

If configured to be a latching alarm, press RESET on the display. If you are accessing the unit from a terminal, type **CA** and press RETURN on your keyboard.

PWR SPLY S2 AC FAIL

Power Supply Source 2 AC Failed

The AC input power to the power supplies from Source 2 has failed. The power supplies are now operating on AC power from Source 1. The AC input from Source 2 is still good.

Contact Liebert for technical support at 1-800-LIEBERT (800-543-2378).

Press SILENCE on the touch screen to turn off the audible alarm, if so configured. If you are accessing the STS2 system from a terminal, type **SH** and press RETURN on your keyboard to turn off the audible alarm.

This event was written to the Event Log, if so configured.

The alarm has triggered a message to be sent to the modem, if so configured.

If configured to be a latching alarm, press RESET on the display. If you are accessing the unit from a terminal, type **CA** and press RETURN on your keyboard.

PWR SPLY LOGIC FAIL

Power Supply Module Failed

The power supply logic module contained in the primary power supply has failed.

Contact Liebert for technical support at 1-800-LIEBERT (800-543-2378).

Press SILENCE on the touch screen to turn off the audible alarm, if so configured. If you are accessing the STS2 system from a terminal, type **SH** and press RETURN on your keyboard to turn off the audible alarm.

This event was written to the Event Log, is so configured.

The alarm has triggered a message to be sent to the modem, if so configured.

If configured to be a latching alarm, press RESET on the display. If you are accessing the unit from a terminal, type **CA** and press RETURN on your keyboard.

OUT VOLT SENSE FAIL

Output Voltage Sense Module Failed

The module contained on the snubber monitoring the output voltage has failed.

Press SILENCE on the touch screen to turn off the audible alarm, if so configured. If you are accessing the STS2 system from a terminal, type **SH** and press RETURN on your keyboard to turn off the audible alarm.

Contact Liebert for technical support at 1-800-LIEBERT (800-543-2378).

This event was written to the Event Log, if so configured.

The alarm has triggered a message to be sent to the modem, if so configured.

If configured to be a latching alarm, press RESET on the display. If you are accessing the unit from a terminal, type **CA** and press RETURN on your keyboard.

S1 VOLT SENSE FAIL

Source 1 Voltage Sense Module Failed

The module contained on the snubber monitoring the input voltage from Source 1 has failed.

Press SILENCE on the touch screen to turn off the audible alarm, if so configured. If you are accessing the STS2 system from a terminal, type **SH** and press RETURN on your keyboard to turn off the audible alarm.

Contact Liebert for technical support at 1-800-LIEBERT (800-543-2378).

This event was written to the Event Log, if so configured.

The alarm has triggered a message to be sent to the modem, if so configured.

If configured to be a latching alarm, press RESET on the display. If you are accessing the unit from a terminal, type **CA** and press RETURN on your keyboard.

S2 VOLT SENSE FAIL

Source 2 Voltage Sense Module Failed

The module contained on the snubber monitoring the input voltage from Source 2 has failed.

Press SILENCE on the touch screen to turn off the audible alarm, if so configured. If you are accessing the STS2 system from a terminal, type **SH** and press RETURN on your keyboard to turn off the audible alarm.

Contact Liebert for technical support at 1-800-LIEBERT (800-543-2378).

This event was written to the Event Log, if so configured.

The alarm has triggered a message to be sent to the modem, if so configured.

If configured to be a latching alarm, press RESET on the display. If you are accessing the STS2 system from a terminal, type **CA** and press RETURN on your keyboard.

S1 SCR SENSE FAIL

Source 1 SCR Sense Module Failed

The module contained on the snubber monitoring the SCRs for Source 1 has failed.

Press SILENCE on the touch screen to turn off the audible alarm, if so configured. If you are accessing the STS2 system from a terminal, type **SH** and press RETURN on your keyboard to turn off the audible alarm.

Contact Liebert for technical support at 1-800-LIEBERT (800-543-2378).

This event was written to the Event Log, if so configured.

The alarm has triggered a message to be sent to the modem, if so configured.

If configured to be a latching alarm, press RESET on the display. If you are accessing the STS2 system from a terminal, type **CA** and press RETURN on your keyboard.

S2 SCR SENSE FAIL

Source 2 SCR Sense Module Failed

The module contained on the snubber monitoring the SCRs for Source 2 has failed.

Press SILENCE on the touch screen to turn off the audible alarm, if so configured. If you are accessing the STS2 system from a terminal, type **SH** and press RETURN on your keyboard to turn off the audible alarm.

Contact Liebert for technical support at 1-800-LIEBERT (800-543-2378).

This event was written to the Event Log, if so configured.

The alarm has triggered a message to be sent to the modem, if so configured.

If configured to be a latching alarm, press RESET on the display. If you are accessing the STS2 system from a terminal, type **CA** and press RETURN on your keyboard.

S1 CURR SENSE FAIL

Source 1 Current Sense Failure

The module monitoring the current from Source 1 has failed. This module is contained on the left side gate driver board.

Press SILENCE on the touch screen to turn off the audible alarm, if so configured. If you are accessing the STS2 system from a terminal, type **SH** and press RETURN on your keyboard to turn off the audible alarm.

This event was written to the Events Log, is so configured.

The alarm has triggered a message to be sent to the modem, if so configured.

If configured to be a latching alarm, press RESET on the display. If you are accessing the STS2 system from a terminal, type **CA** and press RETURN on your keyboard.

S2 CURR SENSE FAIL

Source 2 Current Sense Failure

The module monitoring the current from Source 2 has failed. This module is contained on the right side gate driver board.

Press SILENCE on the touch screen to turn off the audible alarm, if so configured. If you are accessing the STS2 system from a terminal, type **SH** and press RETURN on your keyboard to turn off the audible alarm.

This event was written to the Events Log, is so configured.

The alarm has triggered a message to be sent to the modem, if so configured.

If configured to be a latching alarm, press RESET on the display. If you are accessing the STS2 system from a terminal, type **CA** and press RETURN on your keyboard.

S1 GATE DRIVE FAIL

Source 1 Gate Drive Failure

The gate drive module for an SCR for Source 1 has failed. This module is contained on the right side gate driver board.

Press SILENCE on the touch screen to turn off the audible alarm, if so configured. If you are accessing the STS2 system from a terminal, type **SH** and press RETURN on your keyboard to turn off the audible alarm.

Contact Liebert for technical support at 1-800-LIEBERT (800-543-2378).

This event was written to the Event Log, if so configured.

The alarm has triggered a message to be sent to the modem, if so configured.

If configured to be a latching alarm, press RESET on the display. If you are accessing the STS2 system from a terminal, type **CA** and press RETURN on your keyboard.

S2 GATE DRIVE FAIL

Source 1 Gate Drive Failure

The gate drive module for an SCR for Source 2 has failed. This module is contained on the left side gate driver board.

Press SILENCE on the touch screen to turn off the audible alarm, if so configured. If you are accessing the STS2 system from a terminal, type **SH** and press RETURN on your keyboard to turn off the audible alarm.

Contact Liebert for technical support at 1-800-LIEBERT (800-543-2378).

This event was written to the Event Log, if so configured.

The alarm has triggered a message to be sent to the modem, if so configured.

If configured to be a latching alarm, press RESET on the display. If you are accessing the unit from a terminal, type **CA** and press RETURN on your keyboard.

INTERNAL COMM FAIL

Internal CAN Communications Failed

Communications have failed in the CAN bus between the control board and the touch screen control.

Press SILENCE on the touch screen to turn off the audible alarm, if so configured. If you are accessing the STS2 system from a terminal, type **SH** and press RETURN on your keyboard to turn off the audible alarm.

Contact Liebert for technical support at 1-800-LIEBERT (800-543-2378).

This event was written to the Event Log, if so configured.

The alarm has triggered a message to be sent to the modem, if so configured.

If configured to be a latching alarm, press RESET on the display. If you are accessing the unit from a terminal, type **CA** and press RETURN on your keyboard.

EXTERNAL COMM FAIL

External Communications Failed

Communications have failed between the control board and the CAN options.

Press SILENCE on the touch screen to turn off the audible alarm, if so configured. If you are accessing the unit from a terminal, type **SH** and press RETURNRETURN on your keyboard to turn off the audible alarm.

Contact Liebert for technical support at 1-800-LIEBERT (800-543-2378).

This event was written to the Event Log, if so configured.

The alarm has triggered a message to be sent to the modem, if so configured.

If configured to be a latching alarm, press RESET on the display. If you are accessing the unit from a terminal, type **CA** and press RETURN on your keyboard.

CB1 SHUNT TRIP FAIL

Circuit Breaker 1 Shunt Trip Failure

Circuit Breaker 1 failed to trip open when the control issued a command for the circuit breaker to trip.

Press **SILENCE** on the touch screen to turn off the audible alarm, if so configured. If you are accessing the STS2 system from a terminal, type **SH** and press **RETURN** on your keyboard to turn off the audible alarm.

Contact Liebert for technical support at 1-800-LIEBERT (800-543-2378).

This event was written to the Event Log, if so configured.

The alarm has triggered a message to be sent to the modem, if so configured.

If configured to be a latching alarm, press **RESET** on the display. If you are accessing the unit from a terminal, type **CA** and press **RETURN** on your keyboard.

CB2 SHUNT TRIP FAIL

Circuit Breaker 2 Shunt Trip Failure

Circuit Breaker 2 failed to trip open when the control issued a command for the circuit breaker to trip.

Press **SILENCE** on the touch screen to turn off the audible alarm, if so configured. If you are accessing the STS2 system from a terminal, type **SH** and press **RETURN** on your keyboard to turn off the audible alarm.

Contact Liebert for technical support at 1-800-LIEBERT (800-543-2378).

This event was written to the Event Log, if so configured.

The alarm has triggered a message to be sent to the modem, if so configured.

If configured to be a latching alarm, press **RESET** on the display. If you are accessing the unit from a terminal, type **CA** and press **RETURN** on your keyboard.

HEAT SINK OVERTEMP

Heat Sink Over Temperature

The system heat sink temperature has exceeded the design limits.

Take immediate steps to cool the unit. Remove obstructions from the air inlet in the front of the unit. Remove and replace the air filter behind the front door. A standard furnace filter can be used.

Press **SILENCE** on the touch screen to turn off the audible alarm, if so configured. If you are accessing the STS2 system from a terminal, type **SH** and press **RETURN** on your keyboard to turn off the audible alarm.

This event was written to the Event Log, if so configured.

The alarm has triggered a message to be sent to the modem, if so configured.

S1 UV

Source 1 Under Voltage (fast detection).

The input voltage from Source 1 dropped below a set percentage of the nominal voltage, as set in the Fast UV set point under the User Settings. An S1 Fail alarm was also issued and source transfer has been inhibited.

The load of the STS2 has been transferred to Source 2.

Press SILENCE on the touch screen to turn off the audible alarm, if so configured. If you are accessing the STS2 system from a terminal, type **SH** and press RETURN on your keyboard to turn off the audible alarm.

This event was written to the Event Log, if so configured.

The alarm has triggered a message to be sent to the modem, if so configured.

If configured to be a latching alarm, press RESET on the display. If you are accessing the unit from a terminal, type **CA** and press RETURN on your keyboard.

S1 UV (RMS)

Source 1 Under Voltage (slow detection).

The input voltage from Source 1 remained below a set percentage of the nominal voltage for a designated period, as set in the Slow UV Setting and Slow UV Detection Delay set points configured under the User Settings. An S1 Fail alarm was also issued and source transfer has been inhibited.

The load of the STS2 has been transferred to Source 2.

Press SILENCE on the touch screen to turn off the audible alarm, if so configured. If you are accessing the STS2 system from a terminal, type **SH** and press RETURN on your keyboard to turn off the audible alarm.

The alarm is latched and must be reset after the voltage returns to the nominal voltage. If the Reset option is not configured for AUTO (automatic reset), then the reset action must be done manually. When the voltage is within acceptable parameters, touch the RESET button on the touch screen. If you are accessing the unit from a terminal, type **CA** and press RETURN on your keyboard.

This event was written to the Event Log, if so configured.

The alarm has triggered a message to be sent to the modem, if so configured.

S1 OV

Source 1 Over Voltage.

The input voltage from Source 1 exceeded a set percentage of the nominal voltage, as set in the OV Setting and OV Detection Delay set points configured under the User Settings. An S1 Fail alarm was also issued and source transfer has been inhibited.

The load of the STS2 has been transferred to Source 2.

Press SILENCE on the touch screen to turn off the audible alarm, if so configured. If you are accessing the STS2 system from a terminal, type **SH** and press RETURN on your keyboard to turn off the audible alarm.

This event was written to the Event Log, if so configured.

The alarm has triggered a message to be sent to the modem, if so configured.

If configured to be a latching alarm, press RESET on the display. If you are accessing the unit from a terminal, type **CA** and press RETURN on your keyboard.

S1 OF/UF

Source 1 Over Frequency/Under Frequency

The frequency for Source 1 is running outside the acceptable operating range, as set in the Frequency Trip Point under User Settings. An S1 Fail alarm was also issued and source transfer has been inhibited.

Press SILENCE on the touch screen to turn off the audible alarm, if so configured. If you are accessing the STS2 system from a terminal, type **SH** and press RETURN on your keyboard to turn off the audible alarm.

This event was written to the Event Log, if so configured.

The alarm has triggered a message to be sent to the modem, if so configured.

If configured to be a latching alarm, press RESET on the display. If you are accessing the unit from a terminal, type **CA** and press RETURN on your keyboard.

S1 FAIL

Source 1 Failure

Source 1 has failed due to under voltage (UV), over voltage (OV), or running over or under frequency (OF/UF). This alarm is a companion to S1 UV, S1 UV (RMS), S1 OV and S1 OF/UF.

The load of the STS2 has been transferred to Source 2.

Press SILENCE on the touch screen to turn off the audible alarm, if so configured. If you are accessing the STS2 system from a terminal, type **SH** and press RETURN on your keyboard to turn off the audible alarm.

This event has been written to the Event Log, if so configured.

The alarm has triggered a message to be sent to the modem, if so configured.

If configured to be a latching alarm, press RESET on the display. If you are accessing the unit from a terminal, type **CA** and press RETURN on your keyboard.

S2 UV

Source 2 Under Voltage (fast detection).

The input voltage from Source 2 dropped below a set percentage of the nominal voltage, as set in the Fast UV set point under the User Settings. An S2 Fail alarm was also issued and source transfer has been inhibited.

The load of the STS2 has been transferred to Source 1.

Press SILENCE on the touch screen to turn off the audible alarm, if so configured. If you are accessing the STS2 system from a terminal, type **SH** and press RETURN on your keyboard to turn off the audible alarm.

This event was written to the Event Log, if so configured.

The alarm has triggered a message to be sent to the modem, if so configured.

If configured to be a latching alarm, press RESET on the display. If you are accessing the unit from a terminal, type **CA** and press RETURN on your keyboard.

S2 UV (RMS)

Source 2 Under Voltage (slow detection).

The input voltage from Source 2 remained below a set percentage of the nominal voltage for a designated period, as set in the Slow UV Setting and Slow UV Detection Delay set points configured under the User Settings. An S2 Fail alarm was also issued and source transfer has been inhibited.

The load of the STS2 has been transferred to Source 1.

Press SILENCE on the touch screen to turn off the audible alarm, if so configured. If you are accessing the STS2 system from a terminal, type **SH** and press RETURN on your keyboard to turn off the audible alarm.

The alarm is latched and must be reset after the voltage returns to the nominal voltage. If the Reset option is not configured for AUTO (automatic reset), then the reset action must be done manually. When the voltage is within acceptable parameters, touch the RESET button on the touch screen. If you are accessing the unit from a terminal, type **CA** and press RETURN on your keyboard.

This event was written to the Event Log, if so configured.

S2 OV

Source 2 Over Voltage.

The input voltage from Source 2 exceeded a set percentage of the nominal voltage, as set in the OV Setting and OV Detection Delay set points configured under the User Settings. An S2 Fail alarm was also issued and source transfer has been inhibited.

The load of the STS2 has been transferred to Source 1.

Press SILENCE on the touch screen to turn off the audible alarm, if so configured. If you are accessing the STS2 system from a terminal, type **SH** and press RETURN on your keyboard to turn off the audible alarm.

This event was written to the Event Log, if so configured.

The alarm has triggered a message to be sent to the modem, if so configured.

If configured to be a latching alarm, press RESET on the display. If you are accessing the unit from a terminal, type **CA** and press RETURN on your keyboard.

S2 UF/OF

Source 2 Under Frequency/Over Frequency

The frequency for Source 2 is running outside the acceptable operating range, as set in the Frequency Trip Point under User Settings. An S2 Fail alarm was also issued and source transfer has been inhibited.

Press SILENCE on the touch screen to turn off the audible alarm, if so configured. If you are accessing the STS2 system from a terminal, type **SH** and press RETURN on your keyboard to turn off the audible alarm.

This event was written to the Event Log, if so configured.

The alarm has triggered a message to be sent to the modem, if so configured.

If configured to be a latching alarm, press RESET on the display. If you are accessing the unit from a terminal, type **CA** and press RETURN on your keyboard.

S2 FAIL

Source 2 Failure

Source 2 has failed due to under voltage (UV), over voltage (OV), or running with an over or under frequency (OF/UF). This alarm is a companion to S2 UV, S2 UV (RMS), S2 OV and S2 OF/UF.

The load of the STS2 has been transferred to Source 1.

Press SILENCE on the touch screen to turn off the audible alarm, if so configured. If you are accessing the STS2 system from a terminal, type **SH** and press RETURN on your keyboard to turn off the audible alarm.

This event was written to the Event Log, if so configured.

The alarm has triggered a message to be sent to the modem, if so configured.

If configured to be a latching alarm, press RESET on the display. If you are accessing the unit from a terminal, type **CA** and press RETURN on your keyboard.

S1 OVERCURRENT

Source 1 Overcurrent

STS2 is running on Source 1 and an overload condition has occurred on one or more phases.

Note: The overload setpoint is a single fixed number--101%. An overload condition is detected when the measured load current is equal to or greater than the setpoint.

Press SILENCE on the touch screen to turn off the audible alarm, if so configured. If you are accessing the STS2 system from a terminal, type **SH** and press RETURN on your keyboard to turn off the audible alarm.

This event was written to the Event Log, if so configured.

The alarm has triggered a message to be sent to the modem, if so configured.

If configured to be a latching alarm, press RESET on the display. If you are accessing the unit from a terminal, type **CA** and press RETURN on your keyboard.

S2 OVERCURRENT

Source 1 Overcurrent

STS2 is running on Source 2 and an overload condition has occurred on one or more phases.

Note: The overload setpoint is a single fixed number--101%. An overload condition is detected when the measured load current is equal to or greater than the setpoint.

Press SILENCE on the touch screen to turn off the audible alarm, if so configured. If you are accessing the STS2 system from a terminal, type **SH** and press RETURN on your keyboard to turn off the audible alarm.

This event was written to the Event Log, if so configured.

The alarm has triggered a message to be sent to the modem, if so configured.

If configured to be a latching alarm, press RESET on the display. If you are accessing the unit from a terminal, type **CA** and press RETURN on your keyboard.

S1 I-PEAK

Current Peak on Source 1

The peak current from Source 1 has exceeded the set point as defined in the I-PK Xfer Lockout setting under User Settings.

Transferring to Source 2 has been inhibited.

Press SILENCE on the touch screen to turn off the audible alarm, if so configured. If you are accessing the STS2 system from a terminal, type **SH** and press RETURN on your keyboard to turn off the audible alarm.

This event and the system status surrounding it have been written to a History Log if the History Logs were not already full. This event was also written to the Event Log, if so configured.

If this alarm is configured to automatically reset under the set points for User Settings, the alarm clears itself when the I-Peak condition clears.

If this alarm is set for manual reset mode, the alarm continues to show as active after the current returns to nominal, still inhibiting transfers. You will need to manually reset the alarm. If configured to be a latching alarm, press RESET on the display. If you are accessing the unit from a terminal, type **CA** and press RETURN on your keyboard.

The alarm has triggered a message to be sent to the modem, if so configured.

S2 I-PEAK

Current Peak on Source 2

The peak current from Source 2 has exceeded the set point as defined in the I-PK Xfer Lockout setting under User Settings.

Transferring to Source 1 has been inhibited.

Press SILENCE on the touch screen to turn off the audible alarm, if so configured. If you are accessing the STS2 system from a terminal, type **SH** and press RETURN on your keyboard to turn off the audible alarm.

This event and the system status surrounding it have been written to a History Log if the History Logs were not already full. This event was also written to the Event Log, if so configured.

If this alarm is configured to automatically reset under the set points for User Settings, the alarm clears itself when the I-Peak condition clears.

If this alarm is set for manual reset mode, the alarm continues to show as active after the current returns to nominal, still inhibiting transfers. You will need to manually reset the alarm. If configured to be a latching alarm, press RESET on the display. If you are accessing the unit from a terminal, type **CA** and press RETURN on your keyboard.

The alarm has triggered a message to be sent to the modem, if so configured.

SOURCES OUT OF SYNC

Sources out of synchronization.

The phase difference between Source 1 and Source 2 has exceeded the deviation as set for MANUAL MAX XFER PHASE ANGLE under User Settings.

A manual transfer cannot take place while the sources are not synchronized.

Press SILENCE on the touch screen to turn off the audible alarm, if so configured. If you are accessing the STS2 system from a terminal, type **SH** and press RETURN on your keyboard to turn off the audible alarm.

The event was written to the Event Log, if so configured.

The alarm has triggered a message to be sent to the modem, if so configured.

If configured to be a latching alarm, press RESET on the display. If you are accessing the unit from a terminal, type **CA** and press RETURN on your keyboard.

LOAD ON ALT SOURCE

STS2 load on the alternate source.

The static transfer switch is running on the alternate power source. Check the Event Log to determine the reason for the transfer from the preferred source.

Another event has caused the system to transfer to the alternate source. The system returns the load to the preferred source either automatically or manually, depending on how the system is configured.

In automatic reset mode, the STS2 automatically retransfers to the preferred source after the causal condition clears.

In manual reset mode, the system remains on the alternate source after the causal event clears until you select RESET from the touchscreen, or enter **CA** (Clear Alarms) from a service terminal.

Pressing the RESET button to returns the unit to the preferred source. Ensure that the condition that triggered the switch has been rectified before returning to the preferred source.

Press SILENCE on the touch screen to turn off the audible alarm, if so configured. If you are accessing the STS2 system from a terminal, type **SH** and press RETURN on your keyboard to turn off the audible alarm.

This event was written to the Event Log, if so configured.

The alarm has triggered a message to be sent to the modem, if so configured.

AUTO REXFER INHIBIT

Automatic Retransfer Inhibited.

The system made five transfers from the preferred source to the alternate source in the last five minutes. As a result, automatic retransfers back to the preferred source is now disabled.

To clear this alarm condition, assign the alternate source as the preferred source.

This alarm also is cleared if the unit transfers to the preferred source due to an alternate source AC volt failure (i.e., an emergency transfer.)

Press SILENCE on the touch screen to turn off the audible alarm, if so configured. If you are accessing the STS2 system from a terminal, type **SH** and press RETURN on your keyboard to turn off the audible alarm.

The event was written to the Event Log, if so configured.

The alarm has triggered a message to be sent to the modem, if so configured.

If configured to be a latching alarm, press RESET on the display. If you are accessing the unit from a terminal, type **CA** and press RETURN on your keyboard.

CB1 (S1) OPEN

Circuit Breaker 1 (for Source 1) Open

Circuit Breaker 1 is not closed. CB1 is only assigned to Source 1.

Check that the Circuit Breaker 1 switch is in the desired position.

Press SILENCE on the touch screen to turn off the audible alarm, if so configured. If you are accessing the STS2 system from a terminal, type **SH** and press RETURN on your keyboard to turn off the audible alarm.

This event was written to the Event Log, if so configured.

The alarm has triggered a message to be sent to the modem, if so configured.

If configured to be a latching alarm, press RESET on the display. If you are accessing the unit from a terminal, type **CA** and press RETURN on your keyboard.

CB2 (S2) OPEN

Circuit Breaker 2 (for Source 2) Open

Circuit Breaker 2 is not closed. CB1 is only assigned to Source 2.

Check that the Circuit Breaker 2 switch is in the desired position.

Press **SILENCE** on the touch screen to turn off the audible alarm, if so configured. If you are accessing the STS2 system from a terminal, type **SH** and press **RETURN** on your keyboard to turn off the audible alarm.

This event was written to the Event Log, if so configured.

The alarm has triggered a message to be sent to the modem, if so configured.

If configured to be a latching alarm, press **RESET** on the display. If you are accessing the unit from a terminal, type **CA** and press **RETURN** on your keyboard.

CB4 (S1 BYP) CLOSED

Circuit Breaker 4 (Source 1 Bypass Breaker) Closed

Circuit breaker 4 is not open. The input from Source 1 is bypassing the static transfer switch.

Press **SILENCE** on the touch screen to turn off the audible alarm, if so configured. If you are accessing the STS2 system from a terminal, type **SH** and press **RETURN** on your keyboard to turn off the audible alarm.

This event was written to the Event Log, if so configured.

The alarm has triggered a message to be sent to the modem, if so configured.

If configured to be a latching alarm, press **RESET** on the display. If you are accessing the unit from a terminal, type **CA** and press **RETURN** on your keyboard.

CB5 (S1 BYP) CLOSED

Circuit Breaker 5 (Source 2 Bypass Breaker) Closed

Circuit breaker 5 is not open. The input from Source 2 is bypassing the static transfer switch.

Press **SILENCE** on the touch screen to turn off the audible alarm, if so configured. If you are accessing the STS2 system from a terminal, type **SH** and press **RETURN** on your keyboard to turn off the audible alarm.

This event was written to the Event Log, if so configured.

The alarm has triggered a message to be sent to the modem, if so configured.

If configured to be a latching alarm, press **RESET** on the display. If you are accessing the unit from a terminal, type **CA** and press **RETURN** on your keyboard.

CB3 (OUTPUT) OPEN

Circuit Breaker 3 (Output breaker) Open

Circuit breaker 3 is not closed. This circuit breaker is assigned to the output load. The power flow to the load cannot flow through the static transfer switch.

Press **SILENCE** on the touch screen to turn off the audible alarm, if so configured. If you are accessing the STS2 system from a terminal, type **SH** and press **RETURN** on your keyboard to turn off the audible alarm.

This event was written to the Event Log, if so configured.

The alarm has triggered a message to be sent to the modem, if so configured.

If configured to be a latching alarm, press **RESET** on the display. If you are accessing the unit from a terminal, type **CA** and press **RETURN** on your keyboard.

CB3A (OUTPUT) OPEN

Circuit Breaker 3A (Output breaker) is Open (Optional)

Circuit breaker 3A is not closed. This circuit breaker is assigned to the output load. The power flow to the load cannot flow through the static transfer switch.

Press SILENCE on the touch screen to turn off the audible alarm, if so configured. If you are accessing the STS2 system from a terminal, type **SH** and press RETURN on your keyboard to turn off the audible alarm.

This event was written to the Event Log, if so configured.

The alarm has triggered a message to be sent to the modem, if so configured.

If configured to be a latching alarm, press RESET on the display. If you are accessing the unit from a terminal, type **CA** and press RETURN on your keyboard.

S1 PHASE ROT ERROR

Source 1 Phase Rotation Error

A phase rotation error condition exists on Source 1. Check the phase sequence (ABC) of Source 1.

Transferring to Source 1 has been inhibited.

Press SILENCE on the touch screen to turn off the audible alarm, if so configured. If you are accessing the STS2 system from a terminal, type **SH** and press RETURN on your keyboard to turn off the audible alarm.

This event was written to the Event Log, if so configured.

The alarm has triggered a message to be sent to the modem, if so configured.

If configured to be a latching alarm, press RESET on the display. If you are accessing the unit from a terminal, type **CA** and press RETURN on your keyboard.

S2 PHASE ROT ERROR

Source 2 Phase Rotation Error

A phase rotation error condition exists on Source 2. Check the phase sequence (ABC) of Source 2.

Transferring to Source 1 has been inhibited.

Press SILENCE on the touch screen to turn off the audible alarm, if so configured. If you are accessing the STS2 system from a terminal, type **SH** and press RETURN on your keyboard to turn off the audible alarm.

This event was written to the Event Log, if so configured.

The alarm has triggered a message to be sent to the modem, if so configured.

If configured to be a latching alarm, press RESET on the display. If you are accessing the unit from a terminal, type **CA** and press RETURN on your keyboard.

TRANSFER INHIBITED

Transfer Inhibited

Uninterrupted transfer between sources is inhibited due to input source failure, sources out of sync, switch failure, or the unit is in bypass mode.

Check the Event Log for the event or events that may have caused the alarm.

Press SILENCE on the touch screen to turn off the audible alarm, if so configured. If you are accessing the STS2 system from a terminal, type **SH** and press RETURN on your keyboard to turn off the audible alarm.

This event was written to the Event Log, if so configured.

The alarm has triggered a message to be sent to the modem, if so configured.

If configured to be a latching alarm, press RESET on the display. If you are accessing the unit from a terminal, type **CA** and press RETURN on your keyboard.

OUTPUT UV

Output Undervoltage

The voltage being supplied to the load has dropped below the acceptable nominal voltage. Check the input voltage from both sources.

This event and the system status surrounding it have been written to a History Log if the History Logs were not already full. This event was also written to the Event Log, if so configured.

Press SILENCE on the touch screen to turn off the audible alarm, if so configured. If you are accessing the STS2 system from a terminal, type **SH** and press RETURN on your keyboard to turn off the audible alarm.

The alarm has triggered a message to be sent to the modem, if so configured.

If configured to be a latching alarm, press RESET on the display. If you are accessing the unit from a terminal, type **CA** and press RETURN on your keyboard.

INPUT CONTACT #1

Input Contact Isolator #1

Occurrence of the indicated external event has been detected by Input Contact Isolator #1 of the Open Comms Digital Input option board.

Press SILENCE on the touch screen to turn off the audible alarm, if so configured. If you are accessing the STS2 system from a terminal, type **SH** and press RETURN on your keyboard to turn off the audible alarm.

The event, with its assigned name, was written to the Event Log, if so configured.

The alarm has triggered a message to be sent to the modem, if so configured.

If configured to be a latching alarm, press RESET on the display. If you are accessing the unit from a terminal, type **CA** and press RETURN on your keyboard.

INPUT CONTACT #2

Input Contact Isolator #2

Occurrence of the indicated external event has been detected by Input Contact Isolator #2 of the Open Comms Digital Input option board.

Press SILENCE on the touch screen to turn off the audible alarm, if so configured. If you are accessing the STS2 system from a terminal, type **SH** and press RETURN on your keyboard to turn off the audible alarm.

The event, with its assigned name, was written to the Event Log, if so configured.

The alarm has triggered a message to be sent to the modem, if so configured.

If configured to be a latching alarm, press RESET on the display. If you are accessing the unit from a terminal, type **CA** and press RETURN on your keyboard.

INPUT CONTACT #3

Input Contact Isolator #3

Occurrence of the indicated external event has been detected by Input Contact Isolator #3 of the Open Comms Digital Input option board.

Press SILENCE on the touch screen to turn off the audible alarm, if so configured. If you are accessing the STS2 system from a terminal, type **SH** and press RETURN on your keyboard to turn off the audible alarm.

The event, with its assigned name, was written to the Event Log, if so configured.

The alarm has triggered a message to be sent to the modem, if so configured.

If configured to be a latching alarm, press RESET on the display. If you are accessing the unit from a terminal, type **CA** and press RETURN on your keyboard.

INPUT CONTACT #4

Input Contact Isolator #4

Occurrence of the indicated external event has been detected by Input Contact Isolator #4 of the Open Comms Digital Input option board.

Press SILENCE on the touch screen to turn off the audible alarm, if so configured. If you are accessing the STS2 system from a terminal, type **SH** and press RETURN on your keyboard to turn off the audible alarm.

The event, with its assigned name, was written to the Event Log, if so configured.

The alarm has triggered a message to be sent to the modem, if so configured.

If configured to be a latching alarm, press RESET on the display. If you are accessing the unit from a terminal, type **CA** and press RETURN on your keyboard.

INPUT CONTACT #5

Input Contact Isolator #5

Occurrence of the indicated external event has been detected by Input Contact Isolator #5 of the Open Comms Digital Input option board.

Press SILENCE on the touch screen to turn off the audible alarm, if so configured. If you are accessing the STS2 system from a terminal, type **SH** and press RETURN on your keyboard to turn off the audible alarm.

The event, with its assigned name, was written to the Event Log, if so configured.

The alarm has triggered a message to be sent to the modem, if so configured.

If configured to be a latching alarm, press RESET on the display. If you are accessing the unit from a terminal, type **CA** and press RETURN on your keyboard.

INPUT CONTACT #6

Input Contact Isolator #6

Occurrence of the indicated external event has been detected by Input Contact Isolator #6 of the Open Comms Digital Input option board.

Press SILENCE on the touch screen to turn off the audible alarm, if so configured. If you are accessing the STS2 system from a terminal, type **SH** and press RETURN on your keyboard to turn off the audible alarm.

The event, with its assigned name, was written to the Event Log, if so configured.

The alarm has triggered a message to be sent to the modem, if so configured.

If configured to be a latching alarm, press RESET on the display. If you are accessing the unit from a terminal, type **CA** and press RETURN on your keyboard.

INPUT CONTACT #7

Input Contact Isolator #7

Occurrence of the indicated external event has been detected by Input Contact Isolator #7 of the Open Comms Digital Input option board.

Press SILENCE on the touch screen to turn off the audible alarm, if so configured. If you are accessing the STS2 system from a terminal, type **SH** and press RETURN on your keyboard to turn off the audible alarm.

The event, with its assigned name, was written to the Event Log, if so configured.

The alarm has triggered a message to be sent to the modem, if so configured.

If configured to be a latching alarm, press RESET on the display. If you are accessing the unit from a terminal, type **CA** and press RETURN on your keyboard.

INPUT CONTACT #8

Input Contact Isolator #8

Occurrence of the indicated external event has been detected by Input Contact Isolator #8 of the Open Comms Digital Input option board.

Press SILENCE on the touch screen to turn off the audible alarm, if so configured. If you are accessing the STS2 system from a terminal, type **SH** and press RETURN on your keyboard to turn off the audible alarm.

The event, with its assigned name, was written to the Event Log, if so configured.

The alarm has triggered a message to be sent to the modem, if so configured.

If configured to be a latching alarm, press RESET on the display. If you are accessing the unit from a terminal, type **CA** and press RETURN on your keyboard.

CONFIG MODIFIED

Configuration Modified

A set point has been updated and saved.

Press SILENCE on the touch screen to turn off the audible alarm, if so configured. If you are accessing the STS2 system from a terminal, type **SH** and press RETURN on your keyboard to turn off the audible alarm.

The event was written to the Event Log, if so configured.

The alarm has triggered a message to be sent to the modem, if so configured.

If configured to be a latching alarm, press RESET on the display. If you are accessing the unit from a terminal, type **CA** and press RETURN on your keyboard.

PASSWORD CHANGED

Access Password Changed

The password for accessing the HMI (touch screen) options has been updated and saved.

Press SILENCE on the touch screen to turn off the audible alarm, if so configured. If you are accessing the STS2 system from a terminal, type **SH** and press RETURN on your keyboard to turn off the audible alarm.

The alarm has triggered a message to be sent to the modem, if so configured.

The event was written to the Event Log, if so configured.

If configured to be a latching alarm, press RESET on the display. If you are accessing the unit from a terminal, type **CA** and press RETURN on your keyboard.

TIME REPROGRAMMED

System Time Reprogrammed

The system's time setting has been updated and saved.

Press SILENCE on the touch screen to turn off the audible alarm, if so configured. If you are accessing the STS2 system from a terminal, type **SH** and press RETURN on your keyboard to turn off the audible alarm.

The event was written to the Event Log, if so configured.

The alarm has triggered a message to be sent to the modem, if so configured.

If configured to be a latching alarm, press RESET on the display. If you are accessing the unit from a terminal, type **CA** and press RETURN on your keyboard.

DATE REPROGRAMMED

System Date Reprogrammed

The system's date setting has been updated and saved.

Press SILENCE on the touch screen to turn off the audible alarm, if so configured. If you are accessing the STS2 system from a terminal, type **SH** and press RETURN on your keyboard to turn off the audible alarm.

The event was written to the Event Log, if so configured.

The alarm has triggered a message to be sent to the modem, if so configured.

If configured to be a latching alarm, press RESET on the display. If you are accessing the unit from a terminal, type **CA** and press RETURN on your keyboard.

EVENT LOG CLEARED

Event Log Cleared

All past alarms and faults are no longer recorded in the system's event log.

Press SILENCE on the touch screen to turn off the audible alarm, if so configured. If you are accessing the STS2 system from a terminal, type **SH** and press RETURN on your keyboard to turn off the audible alarm.

This event was written to the Event Log, if so configured.

The alarm has triggered a message to be sent to the modem, if so configured.

If configured to be a latching alarm, press RESET on the display. If you are accessing the unit from a terminal, type **CA** and press RETURN on your keyboard.

HIST LOGS CLEARED

History Logs Cleared

Both History Logs have been erased and the logs are now available to record future events.

Press SILENCE on the touch screen to turn off the audible alarm, if so configured. If you are accessing the STS2 system from a terminal, type **SH** and press RETURN on your keyboard to turn off the audible alarm.

The event was written to the Event Log, if so configured.

The alarm has triggered a message to be sent to the modem, if so configured.

If configured to be a latching alarm, press RESET on the display. If you are accessing the unit from a terminal, type **CA** and press RETURN on your keyboard.

HIST LOGS FULL

History Logs Full

The history buffer has reached its capacity for both history logs. No further history logs can be written until the logs are cleared. The History Logs were frozen by the occurrence of two designated faults or alarms.

Both history logs have been frozen by significant events. These logs contain valuable diagnostic data regarding those events which may be useful if service is required. Once the logs have been analyzed and the causes for freezing them have been resolved, the history logs should be cleared to make them available for capturing future events.

To clear the History Logs, select the CLEAR HLOG button under the LOGS > HISTORY LOG 1 or LOGS > HISTORY LOG 2 menus to clear the History Status buffer after the alarms have been resolved.

If you are accessing the unit from a terminal, type **CHL** and press RETURN to clear the History Logs.

Press SILENCE on the touch screen to turn off the audible alarm, if so configured. If you are accessing the STS2 system from a terminal, type **SH** and press RETURN on your keyboard to turn off the audible alarm.

The event was written to the Event Log, if so configured.

The alarm has triggered a message to be sent to the modem, if so configured.

If configured to be a latching alarm, press RESET on the display. If you are accessing the unit from a terminal, type **CA** and press RETURN on your keyboard.

17.0 MAINTENANCE



WARNING

Only qualified service personnel should perform maintenance on the static switch.

Lethal voltages exist inside the unit during normal operation.

The unit is supplied by multiple ac power sources. disconnect and lock-out all power sources before working inside unit.

Minimal periodic maintenance of the STS2 is required. As with all electrical distribution components, the system should be regularly inspected for electrical connection integrity, signs of excessive temperatures, dirt accumulation, and proper system operation.

17.1 Proper Tightening of Nuts and Bolts

The recommended tightening torque for all nuts and bolts is as shown below, unless otherwise labeled. All power connections are designed to remain at proper torque throughout the lifetime of the unit.

Table 25 Torque tightening

Bolt Shaft Size	Grade 5 -Imperial Grade 8.8 -metric		Electrical Connections with Belleville Washers	
	in-lb (pound-inch)	N-m (Newton-meter)	in-lb (pound.inch)	N-m (Newton.meter)
10-32	25	3	35	4
1/4-20	53	6	80	9.0
5/16-18	107	12	180	20.4
3/8-16	192	22	240	27.1
1/2-13	428	48	480	54.3

17.2 Testing the STS2

The STS2 includes comprehensive system alarms and fault detection to identify operational problems. To increase the degree of confidence of proper system operation, periodic transfer tests can be easily performed. For instructions for changing the preferred source and switching sources:

- For a Color Graphical Display unit, see **10.2 - Manual Transfer / Preferred Source Selection** on page 66.
- For an LED-equipped unit, see **14.2.2 - Manual Transfer / Preferred Source Selection** on page 106.

17.3 Changing the Air Filter

A standard furnace filter is installed behind the air intake in the front door. The air intake allows air to circulate to cool the unit. Replace the filter when it becomes dirty and impedes air flow. The frequency of changing or cleaning the filter depends on the location in which the unit is located.

The size of the filter is 1 in. x 25 in. x 25 in. (2.54 cm x 63.5 cm x 63.5 cm).

SUPPORT INFORMATION

To contact Liebert Global Services for information or repair service in the United States, call **1-800-LIEBERT** (1-800-543-2378). Liebert Global Services is available to assure fast repair of your unit with minimal downtime. Liebert Global Services offers a complete range of start-up services, repair services, preventive maintenance plans, and service contracts.

For repair or maintenance service outside the 48 contiguous states, contact Liebert Global Services, if available in your area. For areas not covered by Liebert Global Services, the authorized distributor is responsible for providing qualified factory-authorized service. Additional telephone numbers and e-mail contact information is on the back page of this manual.

Please have the following information available.

Part Number: _____

Serial Number: _____

Date Purchased: _____

Date Installed: _____

Location: _____

Current Rating: _____

Frequency: _____

Voltage: _____

PROGRAMMABLE RELAY BOARD SETTINGS RECORD

The optional Programmable Relay Board (PRB) has eight channels to report events to an external device. Up to ten (10) events can be programmed to each channel. See **6.1 - Programmable Relay Board** for more information on the PRB.

If your STS2 has the PRB option installed, list the settings below for future reference. If control power is lost in the STS2, the settings are not saved.

Channel 1:			
Channel 2:			
Channel 3:			
Channel 4:			
Channel 5:			
Channel 6:			
Channel 7:			

Channel 8:			
Channel 9:			
Channel 10:			
PRB Notes:			

INPUT CONTACT ISOLATOR SETTINGS RECORD

The Input Contact Isolator board (ICI) provides an STS2 module interface for up to eight external user alarm or message inputs to be routed through the static transfer switch's alarm network. See **6.4 - Input Contact Isolator Board** for more information on the ICI.

If your STS2 has the ICI option installed, list the settings below for future reference. If control power is lost in the STS2, the settings are not saved.

- Channel 1: _____
- Channel 2: _____
- Channel 3: _____
- Channel 4: _____
- Channel 5: _____
- Channel 6: _____
- Channel 7: _____
- Channel 8: _____

STATIC TRANSFER SWITCH 2

USER MANUAL

The Company Behind the Products

With over a million installations around the globe, Liebert is the world leader in computer protection systems. Since its founding in 1965, Liebert has developed a complete range of support and protection systems for sensitive electronics:

- Environmental systems—close-control air conditioning from 1 to 60 tons
- Power conditioning and UPS with power ranges from 300 VA to more than 1000 kVA
- Integrated systems that provide both environmental and power protection in a single, flexible package
- Monitoring and control—from systems of any size or location, on-site or remote
- Service and support through more than 100 service centers around the world and a 24/7 Customer Response Center

While every precaution has been taken to ensure the accuracy and completeness of this literature, Liebert Corporation assumes no responsibility and disclaims all liability for damages resulting from use of this information or for any errors or omissions.

© 2005 Liebert Corporation

All rights reserved throughout the world. Specifications subject to change without notice.

® Liebert and the Liebert logo are registered trademarks of Liebert Corporation. All names referred to are trademarks or registered trademarks of their respective owners.

SL-20620 (6/05) Rev. 5

Technical Support/Service

Web Site

www.liebert.com

Monitoring

800-222-5877

monitoring@liebert.com

Outside the US: 614-841-6755

Single-Phase UPS

800-222-5877

upstech@liebert.com

Outside the US: 614-841-6755

Three-Phase UPS

800-543-2378

powertech@liebert.com

Environmental Systems

800-543-2778

Outside the United States

614-888-0246

Locations

United States

1050 Dearborn Drive

P.O. Box 29186

Columbus, OH 43229

Italy

Via Leonardo Da Vinci 8

Zona Industriale Tognana

35028 Piove Di Sacco (PD)

+39 049 9719 111

Fax: +39 049 5841 257

Asia

7/F, Dah Sing Financial Centre

108 Gloucester Road, Wanchai

Hong Kong

852 25722201

Fax: 852 28029250